

Peroxisomal protein import

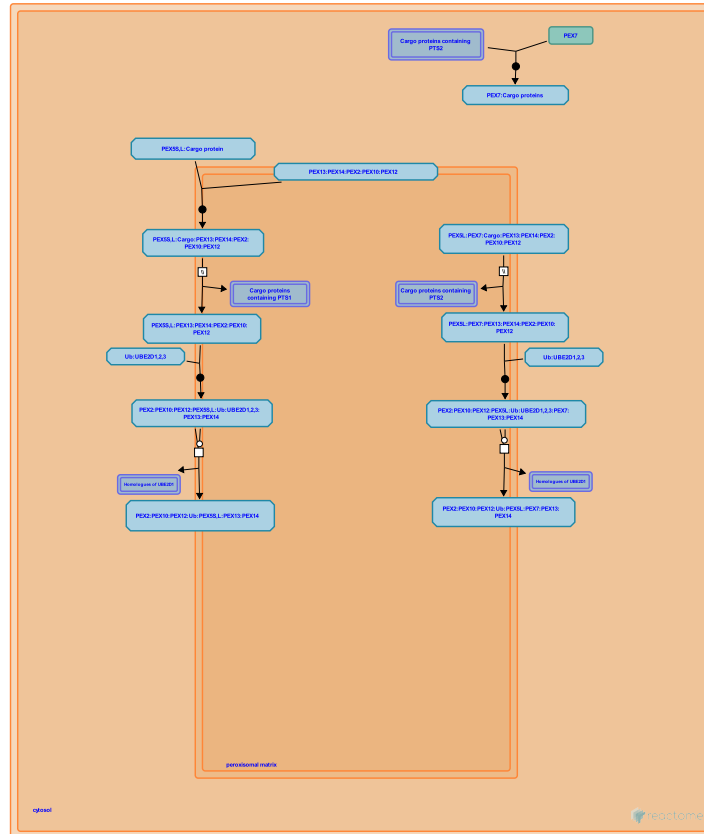

European Bioinformatics Institute, New York University Langone Medical Center, Ontario Institute for Cancer Research, Oregon Health and Science University.

The contents of this document may be freely copied and distributed in any media, provided the authors, plus the institutions, are credited, as stated under the terms of [Creative Commons Attribution 4.0 International \(CC BY 4.0\) License](https://creativecommons.org/licenses/by/4.0/). For more information see our [license](https://reactome.org/licenses/).

This is just an excerpt of a full-length report for this pathway. To access the complete report, please download it at the [Reactome Textbook](https://reactome.org/textbook/).

07/05/2024

Introduction

Reactome is open-source, open access, manually curated and peer-reviewed pathway database. Pathway annotations are authored by expert biologists, in collaboration with Reactome editorial staff and cross-referenced to many bioinformatics databases. A system of evidence tracking ensures that all assertions are backed up by the primary literature. Reactome is used by clinicians, geneticists, genomics researchers, and molecular biologists to interpret the results of high-throughput experimental studies, by bioinformaticians seeking to develop novel algorithms for mining knowledge from genomic studies, and by systems biologists building predictive models of normal and disease variant pathways.

The development of Reactome is supported by grants from the US National Institutes of Health (P41 HG003751), University of Toronto (CFREF Medicine by Design), European Union (EU STRP, EMI-CD), and the European Molecular Biology Laboratory (EBI Industry program).

Literature references

- Fabregat, A., Sidiropoulos, K., Viteri, G., Forner, O., Marin-Garcia, P., Arnau, V. et al. (2017). Reactome pathway analysis: a high-performance in-memory approach. *BMC bioinformatics*, 18, 142. [↗](#)
- Sidiropoulos, K., Viteri, G., Sevilla, C., Jupe, S., Webber, M., Orlic-Milacic, M. et al. (2017). Reactome enhanced pathway visualization. *Bioinformatics*, 33, 3461-3467. [↗](#)
- Fabregat, A., Jupe, S., Matthews, L., Sidiropoulos, K., Gillespie, M., Garapati, P. et al. (2018). The Reactome Pathway Knowledgebase. *Nucleic Acids Res*, 46, D649-D655. [↗](#)
- Fabregat, A., Korninger, F., Viteri, G., Sidiropoulos, K., Marin-Garcia, P., Ping, P. et al. (2018). Reactome graph database: Efficient access to complex pathway data. *PLoS computational biology*, 14, e1005968. [↗](#)

Reactome database release: 88

This document contains 1 pathway and 8 reactions ([see Table of Contents](#))

Peroxisomal protein import ↗

Stable identifier: R-SCE-9033241

Compartments: cytosol, peroxisomal matrix, peroxisomal membrane

Inferred from: Peroxisomal protein import (Homo sapiens)

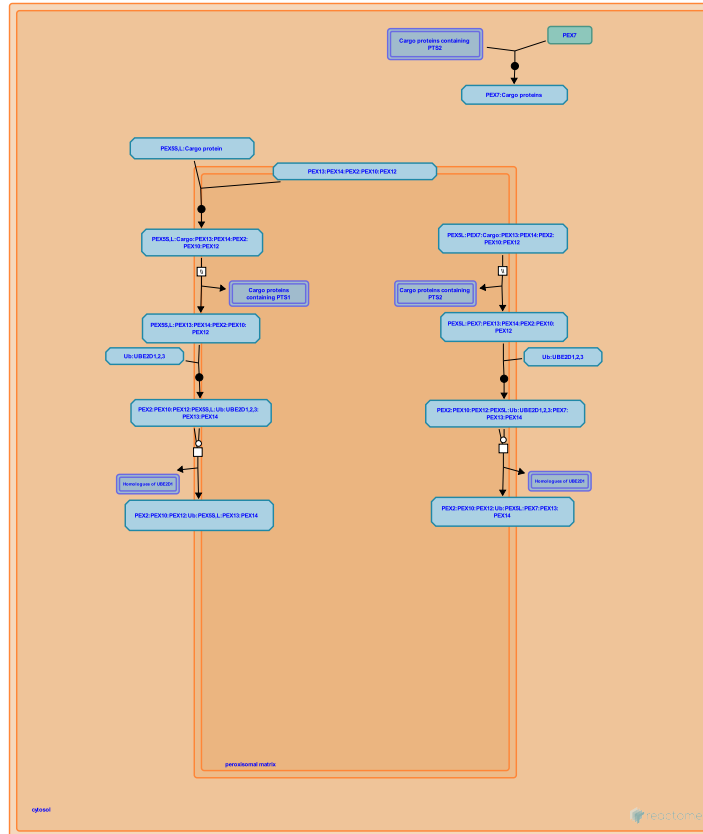

This event has been computationally inferred from an event that has been demonstrated in another species.

The inference is based on the homology mapping from PANTHER. Briefly, reactions for which all involved PhysicalEntities (in input, output and catalyst) have a mapped orthologue/paralogue (for complexes at least 75% of components must have a mapping) are inferred to the other species. High level events are also inferred for these events to allow for easier navigation.

[More details and caveats of the event inference in Reactome.](http://www.pantherdb.org/about.jsp) For details on PANTHER see also: <http://www.pantherdb.org/about.jsp>

PEX5S,L:Cargo binds PEX13:PEX14:PEX2:PEX10:PEX12 (Docking and Translocation Module) ↗

Location: Peroxisomal protein import

Stable identifier: R-SCE-9033236

Type: binding

Compartments: peroxisomal membrane

Inferred from: PEX5S,L:Cargo binds PEX13:PEX14:PEX2:PEX10:PEX12 (Docking and Translocation Module) (Homo sapiens)

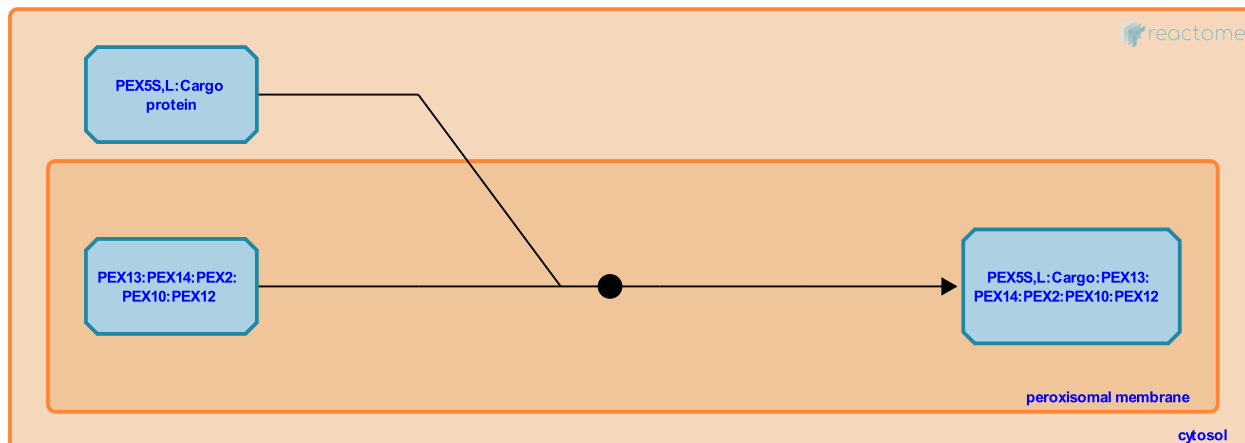

This event has been computationally inferred from an event that has been demonstrated in another species.

The inference is based on the homology mapping from PANTHER. Briefly, reactions for which all involved PhysicalEntities (in input, output and catalyst) have a mapped orthologue/paralogue (for complexes at least 75% of components must have a mapping) are inferred to the other species. High level events are also inferred for these events to allow for easier navigation.

[More details and caveats of the event inference in Reactome.](http://www.pantherdb.org/about.jsp) For details on PANTHER see also: <http://www.pantherdb.org/about.jsp>

Followed by: Cargo of PEX5S,L translocates from the cytosol to the peroxisomal matrix

Cargo of PEX5S,L translocates from the cytosol to the peroxisomal matrix ↗

Location: Peroxisomal protein import

Stable identifier: R-SCE-9033235

Type: omitted

Compartments: peroxisomal membrane

Inferred from: Cargo of PEX5S,L translocates from the cytosol to the peroxisomal matrix (Homo sapiens)

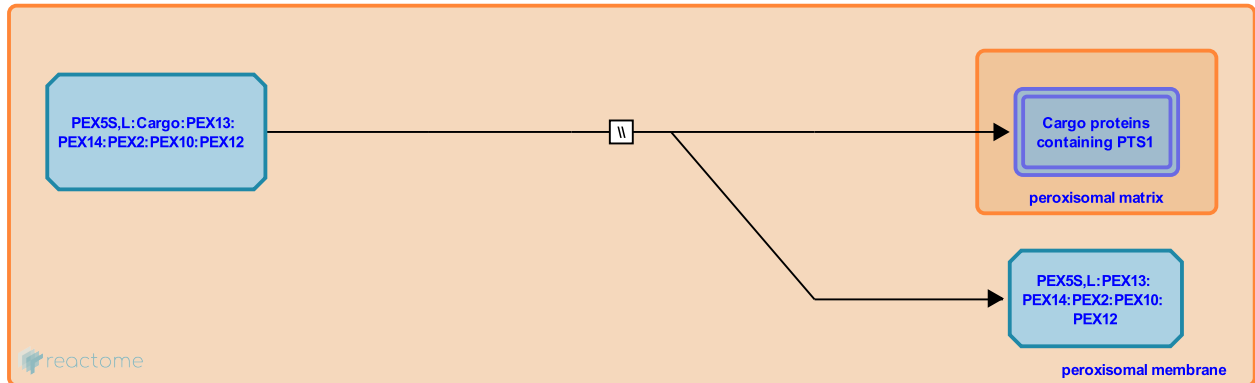

This event has been computationally inferred from an event that has been demonstrated in another species.

The inference is based on the homology mapping from PANTHER. Briefly, reactions for which all involved PhysicalEntities (in input, output and catalyst) have a mapped orthologue/paralogue (for complexes at least 75% of components must have a mapping) are inferred to the other species. High level events are also inferred for these events to allow for easier navigation.

[More details and caveats of the event inference in Reactome.](#) For details on PANTHER see also: <http://www.pantherdb.org/about.jsp>

Preceded by: PEX5S,L:Cargo binds PEX13:PEX14:PEX2:PEX10:PEX12 (Docking and Translocation Module)

Followed by: PEX2:PEX10:PEX12 binds PEX5S,L (in PEX5S:PEX13:PEX14) and Ub:UBE2D1,2,3

PEX2:PEX10:PEX12 binds PEX5S,L (in PEX5S:PEX13:PEX14) and Ub:UBE2D1,2,3 ↗

Location: Peroxisomal protein import

Stable identifier: R-SCE-8953917

Type: binding

Compartments: peroxisomal membrane

Inferred from: PEX2:PEX10:PEX12 binds PEX5S,L (in PEX5S:PEX13:PEX14) and Ub:UBE2D1,2,3 (Homo sapiens)

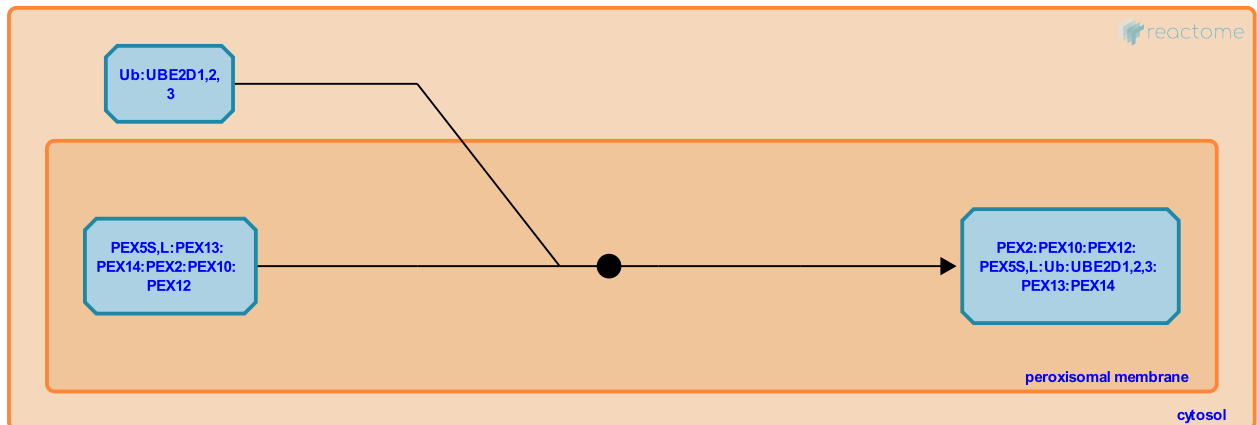

This event has been computationally inferred from an event that has been demonstrated in another species.

The inference is based on the homology mapping from PANTHER. Briefly, reactions for which all involved PhysicalEntities (in input, output and catalyst) have a mapped orthologue/paralogue (for complexes at least 75% of components must have a mapping) are inferred to the other species. High level events are also inferred for these events to allow for easier navigation.

[More details and caveats of the event inference in Reactome.](http://www.pantherdb.org/about.jsp) For details on PANTHER see also: <http://www.pantherdb.org/about.jsp>

Preceded by: Cargo of PEX5S,L translocates from the cytosol to the peroxisomal matrix

Followed by: PEX2:PEX10:PEX12 monoubiquitinates PEX5S,L at cysteine-11

PEX2:PEX10:PEX12 monoubiquitinates PEX5S,L at cysteine-11 ↗

Location: Peroxisomal protein import

Stable identifier: R-SCE-8953946

Type: transition

Compartments: peroxisomal membrane

Inferred from: PEX2:PEX10:PEX12 monoubiquitinates PEX5S,L at cysteine-11 (Homo sapiens)

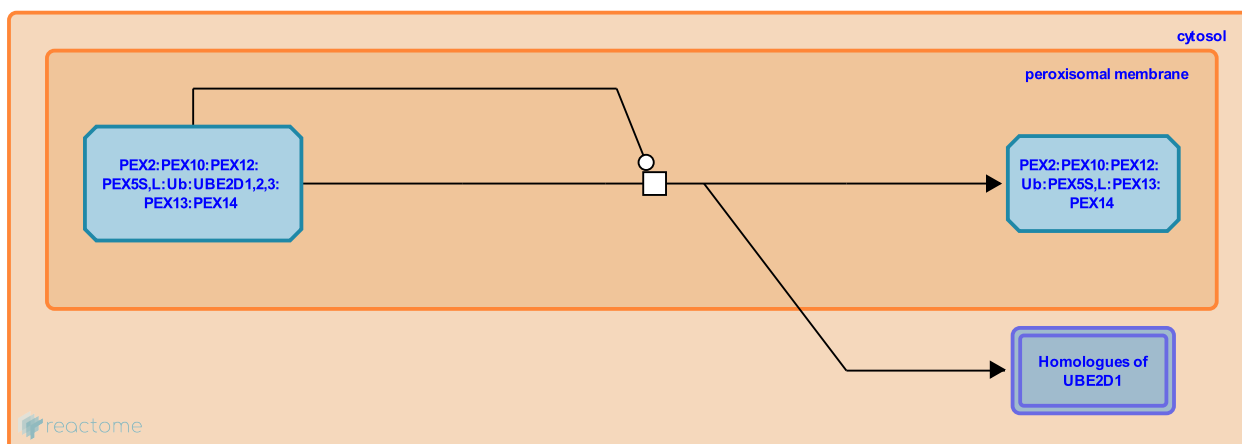

This event has been computationally inferred from an event that has been demonstrated in another species.

The inference is based on the homology mapping from PANTHER. Briefly, reactions for which all involved PhysicalEntities (in input, output and catalyst) have a mapped orthologue/paralogue (for complexes at least 75% of components must have a mapping) are inferred to the other species. High level events are also inferred for these events to allow for easier navigation.

[More details and caveats of the event inference in Reactome.](http://www.pantherdb.org/about.jsp) For details on PANTHER see also: <http://www.pantherdb.org/about.jsp>

Preceded by: PEX2:PEX10:PEX12 binds PEX5S,L (in PEX5S:PEX13:PEX14) and Ub:UBE2D1,2,3

PEX7 binds cargo proteins containing PTS2 ↗

Location: [Peroxisomal protein import](#)

Stable identifier: R-SCE-9033232

Type: binding

Compartments: cytosol

Inferred from: [PEX7 binds cargo proteins containing PTS2 \(Homo sapiens\)](#)

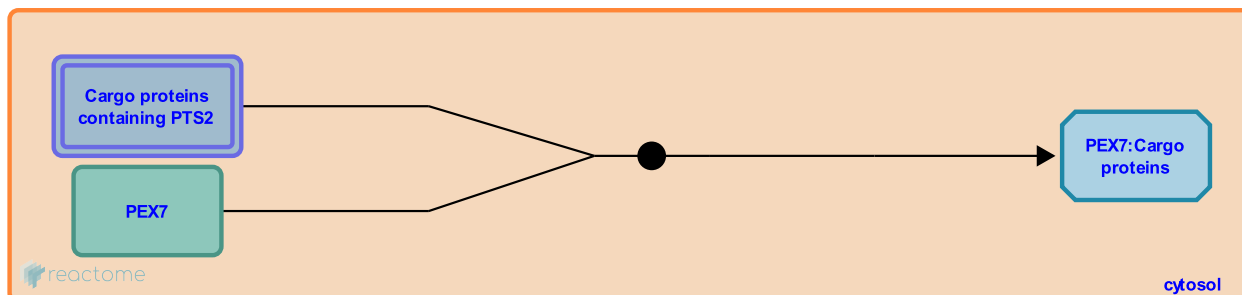

This event has been computationally inferred from an event that has been demonstrated in another species.

The inference is based on the homology mapping from PANTHER. Briefly, reactions for which all involved PhysicalEntities (in input, output and catalyst) have a mapped orthologue/paralogue (for complexes at least 75% of components must have a mapping) are inferred to the other species. High level events are also inferred for these events to allow for easier navigation.

[More details and caveats of the event inference in Reactome.](#) For details on PANTHER see also: <http://www.pantherdb.org/about.jsp>

Cargo of PEX5L:PEX7 translocates from the cytosol to the peroxisomal matrix ↗

Location: Peroxisomal protein import

Stable identifier: R-SCE-9033514

Type: omitted

Compartments: peroxisomal membrane

Inferred from: Cargo of PEX5L:PEX7 translocates from the cytosol to the peroxisomal matrix (Homo sapiens)

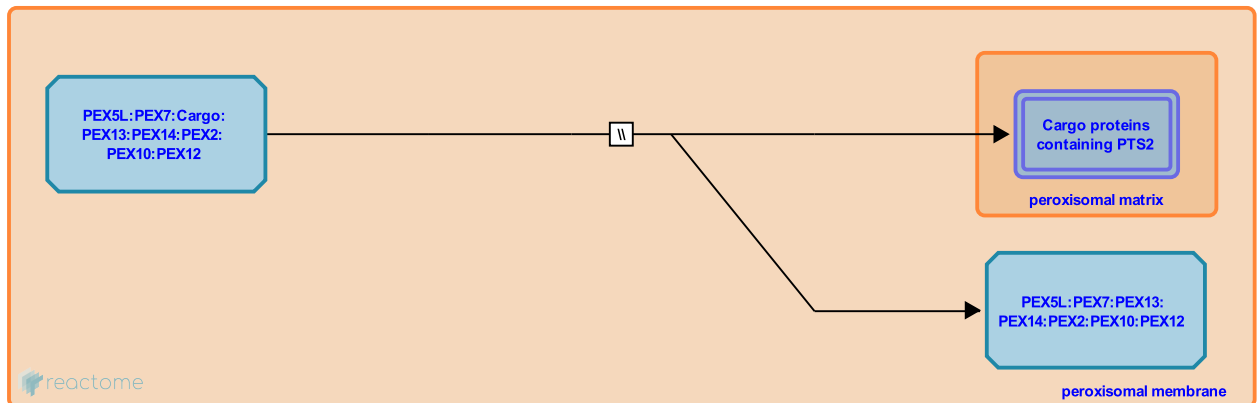

This event has been computationally inferred from an event that has been demonstrated in another species.

The inference is based on the homology mapping from PANTHER. Briefly, reactions for which all involved PhysicalEntities (in input, output and catalyst) have a mapped orthologue/paralogue (for complexes at least 75% of components must have a mapping) are inferred to the other species. High level events are also inferred for these events to allow for easier navigation.

[More details and caveats of the event inference in Reactome.](http://www.pantherdb.org/about.jsp) For details on PANTHER see also: <http://www.pantherdb.org/about.jsp>

Followed by: PEX2:PEX10:PEX12 binds PEX5L (in PEX5L:PEX7:PEX13:PEX14:PEX2:PEX10:PEX12) and Ub:UBE2D1,2,3

PEX2:PEX10:PEX12 binds PEX5L (in PEX5L:PEX7:PEX13:PEX14:PEX2:PEX10:PEX12) and Ub:UBE2D1,2,3 ↗

Location: Peroxisomal protein import

Stable identifier: R-SCE-9033527

Type: binding

Compartments: peroxisomal membrane

Inferred from: PEX2:PEX10:PEX12 binds PEX5L (in PEX5L:PEX7:PEX13:PEX14:PEX2:PEX10:PEX12) and Ub:UBE2D1,2,3 (Homo sapiens)

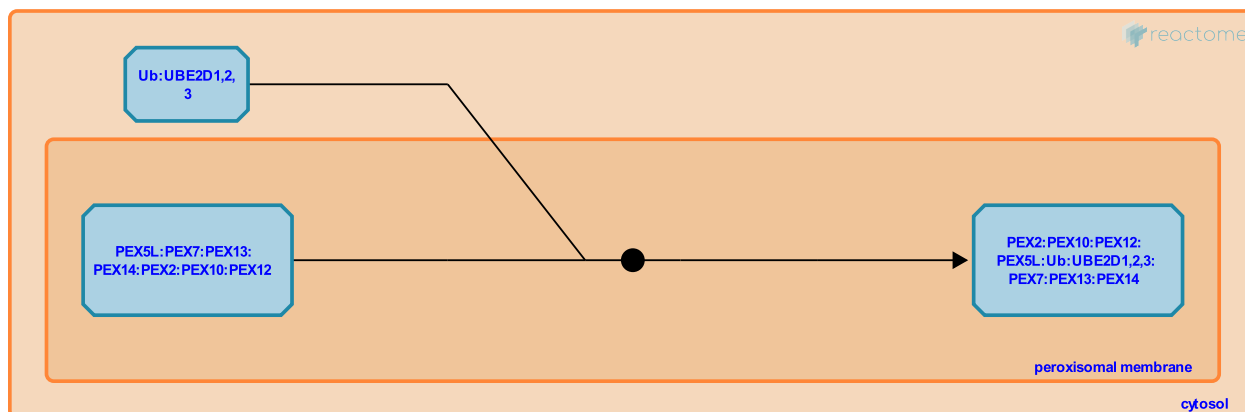

This event has been computationally inferred from an event that has been demonstrated in another species.

The inference is based on the homology mapping from PANTHER. Briefly, reactions for which all involved PhysicalEntities (in input, output and catalyst) have a mapped orthologue/paralogue (for complexes at least 75% of components must have a mapping) are inferred to the other species. High level events are also inferred for these events to allow for easier navigation.

[More details and caveats of the event inference in Reactome.](http://www.pantherdb.org/about.jsp) For details on PANTHER see also: <http://www.pantherdb.org/about.jsp>

Preceded by: Cargo of PEX5L:PEX7 translocates from the cytosol to the peroxisomal matrix

Followed by: PEX2:PEX10:PEX12 monoubiquitinates PEX5L at cysteine-11

PEX2:PEX10:PEX12 monoubiquitinates PEX5L at cysteine-11 [↗](#)

Location: [Peroxisomal protein import](#)

Stable identifier: R-SCE-9033485

Type: transition

Compartments: peroxisomal membrane

Inferred from: [PEX2:PEX10:PEX12 monoubiquitinates PEX5L at cysteine-11 \(Homo sapiens\)](#)

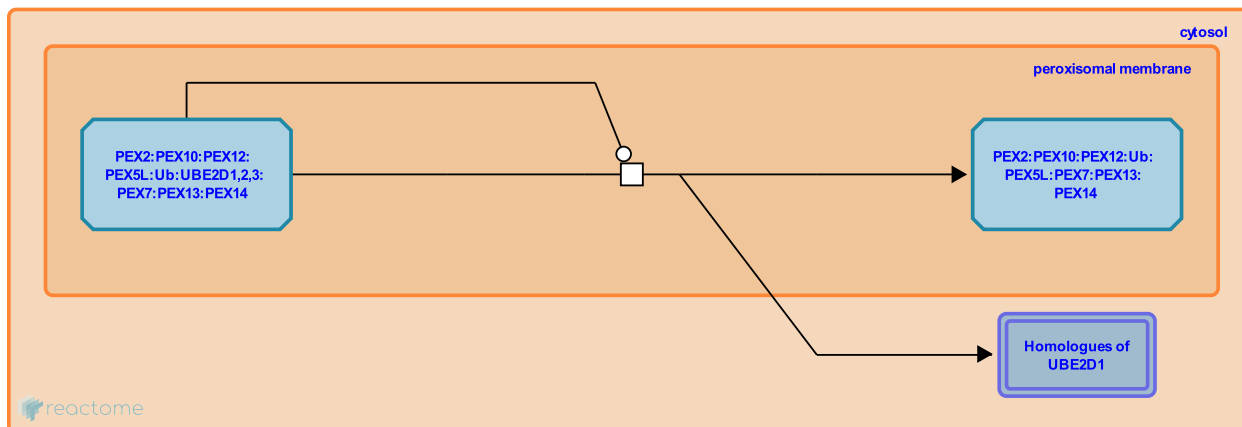

This event has been computationally inferred from an event that has been demonstrated in another species.

The inference is based on the homology mapping from PANTHER. Briefly, reactions for which all involved PhysicalEntities (in input, output and catalyst) have a mapped orthologue/paralogue (for complexes at least 75% of components must have a mapping) are inferred to the other species. High level events are also inferred for these events to allow for easier navigation.

[More details and caveats of the event inference in Reactome.](#) For details on PANTHER see also: <http://www.pantherdb.org/about.jsp>

Preceded by: [PEX2:PEX10:PEX12 binds PEX5L \(in PEX5L:PEX7:PEX13:PEX14:PEX2:PEX10:PEX12\)](#) and [Ub:UBE2D1,2,3](#)

Table of Contents

Introduction	1
❏ Peroxisomal protein import	2
↳ PEX5S,L:Cargo binds PEX13:PEX14:PEX2:PEX10:PEX12 (Docking and Translocation Module)	3
↳ Cargo of PEX5S,L translocates from the cytosol to the peroxisomal matrix	4
↳ PEX2:PEX10:PEX12 binds PEX5S,L (in PEX5S:PEX13:PEX14) and Ub:UBE2D1,2,3	5
↳ PEX2:PEX10:PEX12 monoubiquitinates PEX5S,L at cysteine-11	6
↳ PEX7 binds cargo proteins containing PTS2	7
↳ Cargo of PEX5L:PEX7 translocates from the cytosol to the peroxisomal matrix	8
↳ PEX2:PEX10:PEX12 binds PEX5L (in PEX5L:PEX7:PEX13:PEX14:PEX2:PEX10:PEX12) and Ub:UBE2D1,2,3	9
↳ PEX2:PEX10:PEX12 monoubiquitinates PEX5L at cysteine-11	10
Table of Contents	11