

# Integrin signaling

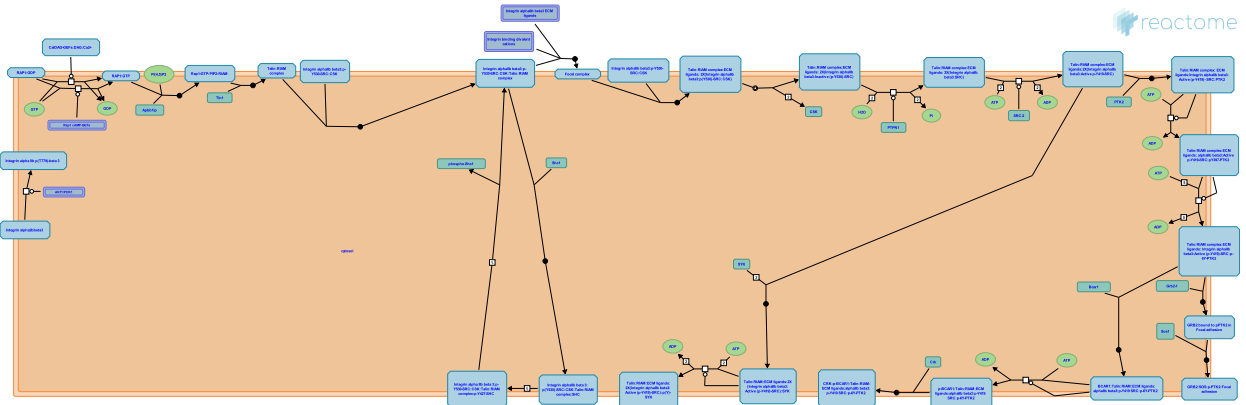

European Bioinformatics Institute, New York University Langone Medical Center, Ontario Institute for Cancer Research, Oregon Health and Science University.

The contents of this document may be freely copied and distributed in any media, provided the authors, plus the institutions, are credited, as stated under the terms of [Creative Commons Attribution 4.0 International \(CC BY 4.0\) License](https://creativecommons.org/licenses/by/4.0/). For more information see our [license](https://reactome.org/faq).

This is just an excerpt of a full-length report for this pathway. To access the complete report, please download it at the [Reactome Textbook](https://reactome.org/Textbook).

06/05/2024

## Introduction

Reactome is open-source, open access, manually curated and peer-reviewed pathway database. Pathway annotations are authored by expert biologists, in collaboration with Reactome editorial staff and cross-referenced to many bioinformatics databases. A system of evidence tracking ensures that all assertions are backed up by the primary literature. Reactome is used by clinicians, geneticists, genomics researchers, and molecular biologists to interpret the results of high-throughput experimental studies, by bioinformaticians seeking to develop novel algorithms for mining knowledge from genomic studies, and by systems biologists building predictive models of normal and disease variant pathways.

The development of Reactome is supported by grants from the US National Institutes of Health (P41 HG003751), University of Toronto (CFREF Medicine by Design), European Union (EU STRP, EMI-CD), and the European Molecular Biology Laboratory (EBI Industry program).

## Literature references

- Fabregat, A., Sidiropoulos, K., Viteri, G., Forner, O., Marin-Garcia, P., Arnau, V. et al. (2017). Reactome pathway analysis: a high-performance in-memory approach. *BMC bioinformatics*, 18, 142. [↗](#)
- Sidiropoulos, K., Viteri, G., Sevilla, C., Jupe, S., Webber, M., Orlic-Milacic, M. et al. (2017). Reactome enhanced pathway visualization. *Bioinformatics*, 33, 3461-3467. [↗](#)
- Fabregat, A., Jupe, S., Matthews, L., Sidiropoulos, K., Gillespie, M., Garapati, P. et al. (2018). The Reactome Pathway Knowledgebase. *Nucleic Acids Res*, 46, D649-D655. [↗](#)
- Fabregat, A., Korninger, F., Viteri, G., Sidiropoulos, K., Marin-Garcia, P., Ping, P. et al. (2018). Reactome graph database: Efficient access to complex pathway data. *PLoS computational biology*, 14, e1005968. [↗](#)

Reactome database release: 88

This document contains 3 pathways and 19 reactions ([see Table of Contents](#))

## Integrin signaling ↗

**Stable identifier:** R-MMU-354192

**Inferred from:** [Integrin signaling \(Homo sapiens\)](#)

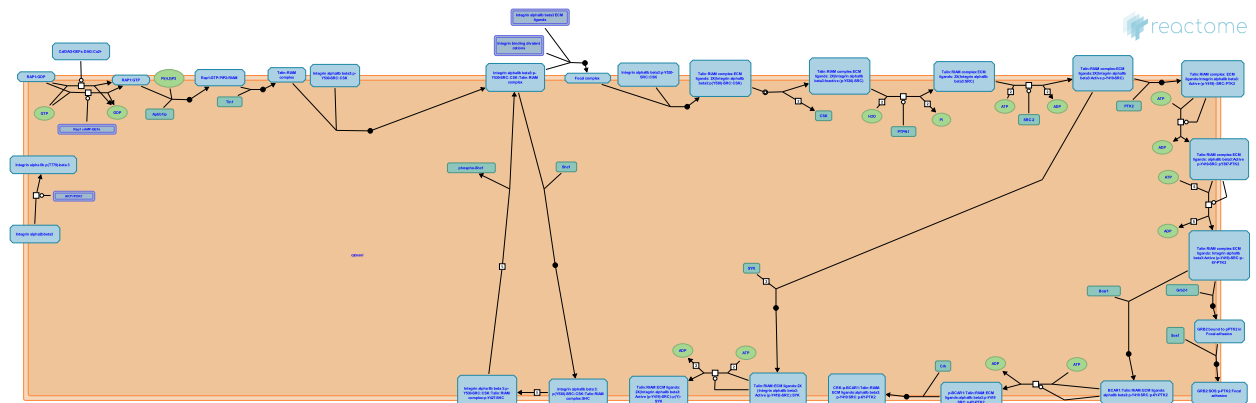

This event has been computationally inferred from an event that has been demonstrated in another species.

The inference is based on the homology mapping from PANTHER. Briefly, reactions for which all involved PhysicalEntities (in input, output and catalyst) have a mapped orthologue/paralogue (for complexes at least 75% of components must have a mapping) are inferred to the other species. High level events are also inferred for these events to allow for easier navigation.

[More details and caveats of the event inference in Reactome.](#) For details on PANTHER see also: <http://www.pantherdb.org/about.jsp>

## Activation of Rap1 by cytosolic GEFs ↗

**Location:** [Integrin signaling](#)

**Stable identifier:** R-MMU-354173

**Type:** transition

**Compartments:** plasma membrane, cytosol

**Inferred from:** [Activation of Rap1 by cytosolic GEFs \(Homo sapiens\)](#)

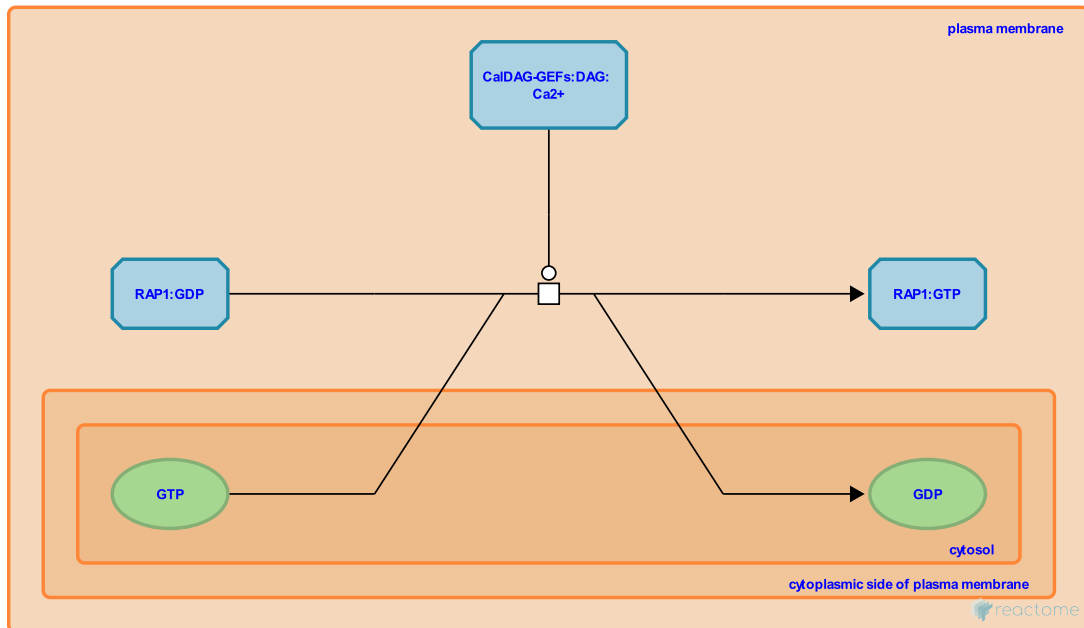

This event has been computationally inferred from an event that has been demonstrated in another species.

The inference is based on the homology mapping from PANTHER. Briefly, reactions for which all involved PhysicalEntities (in input, output and catalyst) have a mapped orthologue/paralogue (for complexes at least 75% of components must have a mapping) are inferred to the other species. High level events are also inferred for these events to allow for easier navigation.

[More details and caveats of the event inference in Reactome.](#) For details on PANTHER see also: <http://www.pantherdb.org/about.jsp>

**Followed by:** [Translocation of RIAM to plasma membrane](#)

## Activation of Rap1 by membrane-associated GEFs ↗

**Location:** [Integrin signaling](#)

**Stable identifier:** R-MMU-939265

**Type:** transition

**Compartments:** plasma membrane, cytosol

**Inferred from:** [Activation of Rap1 by membrane-associated GEFs \(Homo sapiens\)](#)

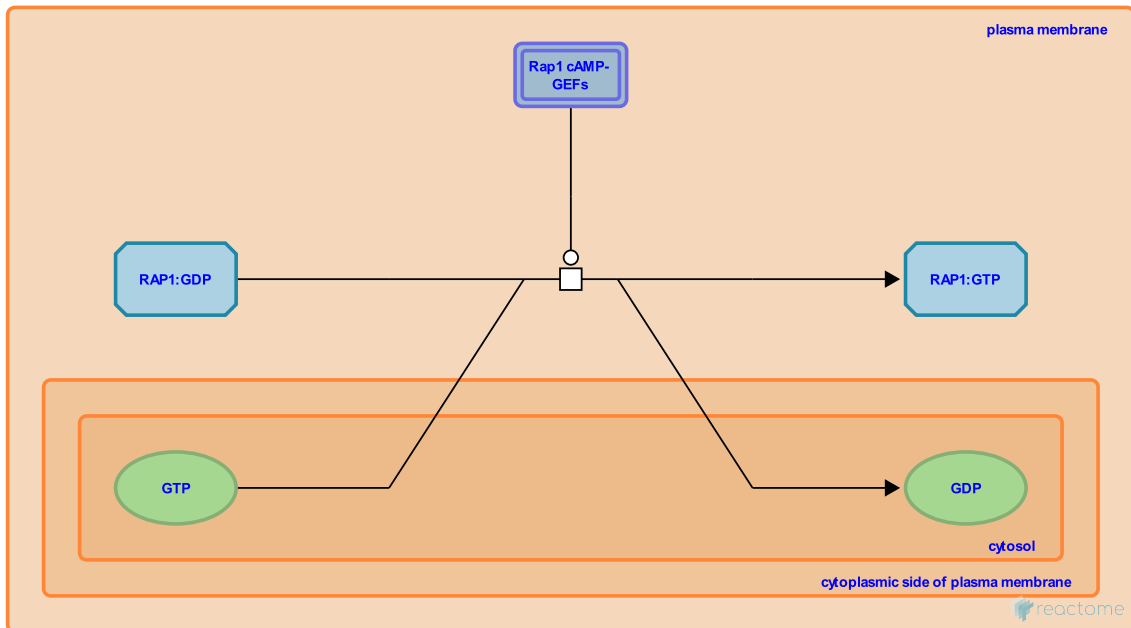

This event has been computationally inferred from an event that has been demonstrated in another species.

The inference is based on the homology mapping from PANTHER. Briefly, reactions for which all involved PhysicalEntities (in input, output and catalyst) have a mapped orthologue/paralogue (for complexes at least 75% of components must have a mapping) are inferred to the other species. High level events are also inferred for these events to allow for easier navigation.

[More details and caveats of the event inference in Reactome.](#) For details on PANTHER see also: <http://www.pantherdb.org/about.jsp>

**Followed by:** [Translocation of RIAM to plasma membrane](#)

## Translocation of RIAM to plasma membrane ↗

**Location:** [Integrin signaling](#)

**Stable identifier:** R-MMU-354060

**Type:** binding

**Compartments:** plasma membrane, cytosol

**Inferred from:** [Translocation of RIAM to plasma membrane \(Homo sapiens\)](#)

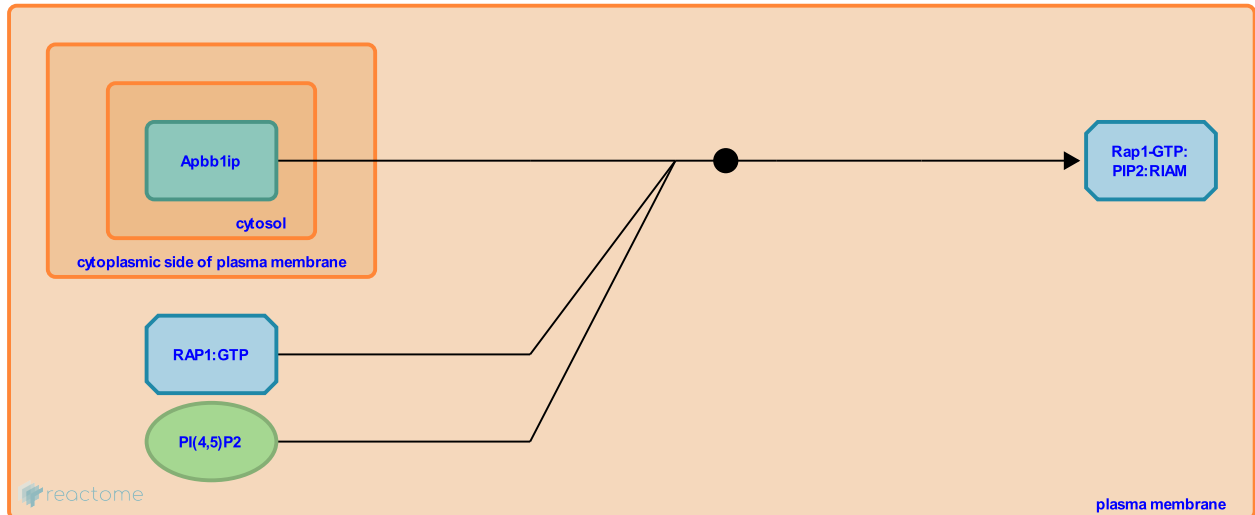

This event has been computationally inferred from an event that has been demonstrated in another species.

The inference is based on the homology mapping from PANTHER. Briefly, reactions for which all involved PhysicalEntities (in input, output and catalyst) have a mapped orthologue/paralogue (for complexes at least 75% of components must have a mapping) are inferred to the other species. High level events are also inferred for these events to allow for easier navigation.

[More details and caveats of the event inference in Reactome.](#) For details on PANTHER see also: <http://www.pantherdb.org/about.jsp>

**Preceded by:** [Activation of Rap1 by membrane-associated GEFs](#), [Activation of Rap1 by cytosolic GEFs](#)

**Followed by:** [Activation of Talin](#)

## Activation of Talin ↗

**Location:** [Integrin signaling](#)

**Stable identifier:** R-MMU-354097

**Type:** binding

**Compartments:** plasma membrane, cytosol

**Inferred from:** [Activation of Talin \(Homo sapiens\)](#)

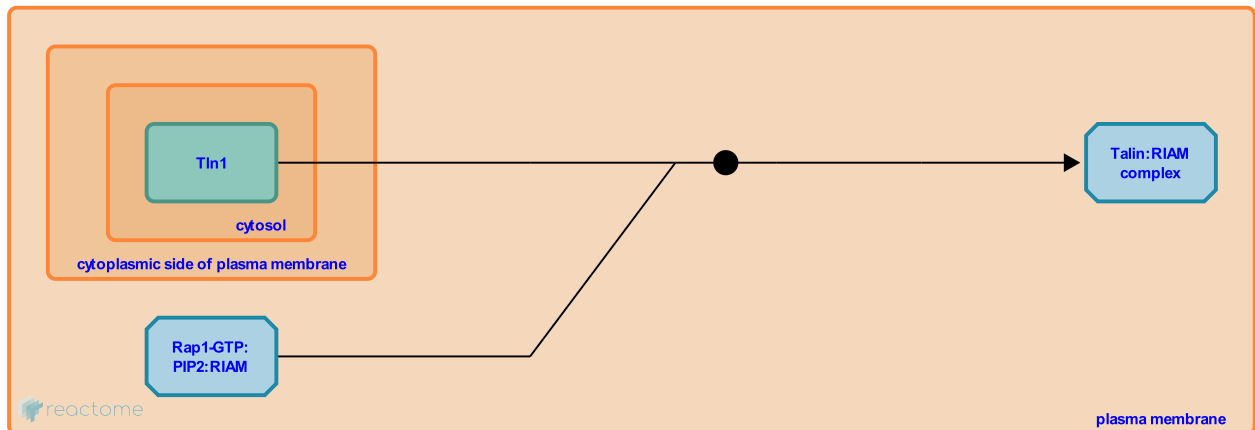

This event has been computationally inferred from an event that has been demonstrated in another species.

The inference is based on the homology mapping from PANTHER. Briefly, reactions for which all involved PhysicalEntities (in input, output and catalyst) have a mapped orthologue/paralogue (for complexes at least 75% of components must have a mapping) are inferred to the other species. High level events are also inferred for these events to allow for easier navigation.

[More details and caveats of the event inference in Reactome.](#) For details on PANTHER see also: <http://www.pantherdb.org/about.jsp>

**Preceded by:** [Translocation of RIAM to plasma membrane](#)

**Followed by:** [Integrin alphaIIb beta3 activation](#)

## Integrin alphaIIb beta3 activation ↗

**Location:** [Integrin signaling](#)

**Stable identifier:** R-MMU-354077

**Type:** binding

**Compartments:** plasma membrane

**Inferred from:** [Integrin alphaIIb beta3 activation \(Homo sapiens\)](#)

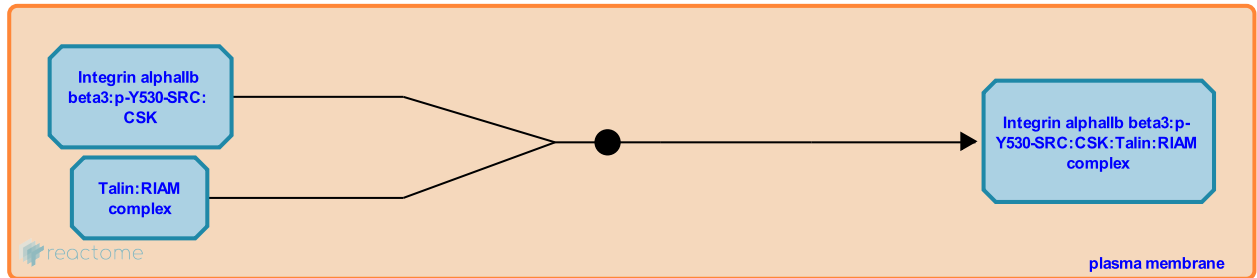

This event has been computationally inferred from an event that has been demonstrated in another species.

The inference is based on the homology mapping from PANTHER. Briefly, reactions for which all involved PhysicalEntities (in input, output and catalyst) have a mapped orthologue/paralogue (for complexes at least 75% of components must have a mapping) are inferred to the other species. High level events are also inferred for these events to allow for easier navigation.

[More details and caveats of the event inference in Reactome.](#) For details on PANTHER see also: <http://www.pantherdb.org/about.jsp>

**Preceded by:** [Activation of Talin](#)

**Followed by:** [Activated integrin alphaIIb beta3 binds SHC1](#), [Interaction of integrin alphaIIb beta3 with Fibrinogen](#)



## Interaction of integrin alphaIIb beta3 with Fibrinogen ↗

**Location:** [Integrin signaling](#)

**Stable identifier:** R-MMU-354149

**Type:** binding

**Compartments:** plasma membrane, extracellular region

**Inferred from:** [Interaction of integrin alphaIIb beta3 with Fibrinogen \(Homo sapiens\)](#)

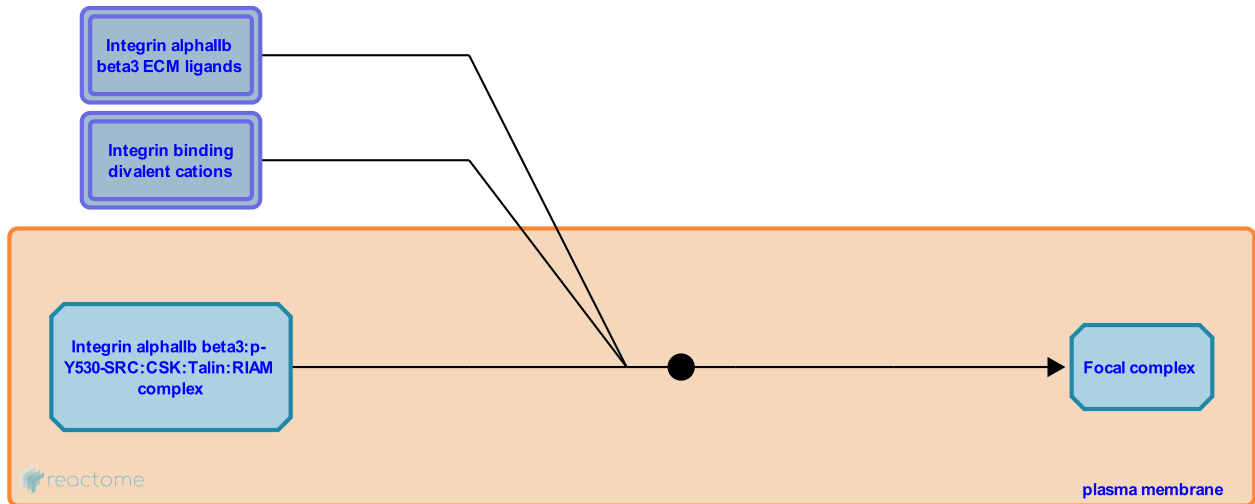

This event has been computationally inferred from an event that has been demonstrated in another species.

The inference is based on the homology mapping from PANTHER. Briefly, reactions for which all involved PhysicalEntities (in input, output and catalyst) have a mapped orthologue/paralogue (for complexes at least 75% of components must have a mapping) are inferred to the other species. High level events are also inferred for these events to allow for easier navigation.

[More details and caveats of the event inference in Reactome.](#) For details on PANTHER see also: <http://www.pantherdb.org/about.jsp>

**Preceded by:** [Integrin alphaIIb beta3 activation](#)

**Followed by:** [Clustering of Integrin alphaIIb beta3 complexes](#)

## Clustering of Integrin alphaIIb beta3 complexes ↗

**Location:** [Integrin signaling](#)

**Stable identifier:** R-MMU-377641

**Type:** binding

**Compartments:** plasma membrane

**Inferred from:** [Clustering of Integrin alphaIIb beta3 complexes \(Homo sapiens\)](#)

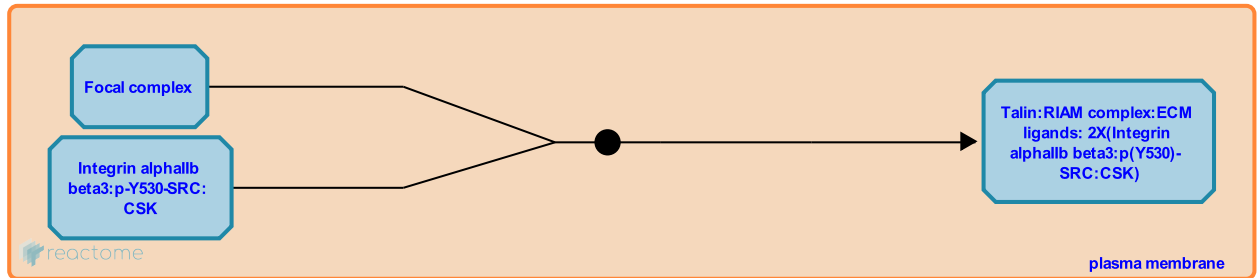

This event has been computationally inferred from an event that has been demonstrated in another species.

The inference is based on the homology mapping from PANTHER. Briefly, reactions for which all involved PhysicalEntities (in input, output and catalyst) have a mapped orthologue/paralogue (for complexes at least 75% of components must have a mapping) are inferred to the other species. High level events are also inferred for these events to allow for easier navigation.

[More details and caveats of the event inference in Reactome.](#) For details on PANTHER see also: <http://www.pantherdb.org/about.jsp>

**Preceded by:** [Interaction of integrin alphaIIb beta3 with Fibrinogen](#)

**Followed by:** [Release of CSK from SRC](#)

## Release of CSK from SRC ↗

**Location:** [Integrin signaling](#)

**Stable identifier:** R-MMU-377644

**Type:** dissociation

**Compartments:** plasma membrane, cytosol

**Inferred from:** [Release of CSK from SRC \(Homo sapiens\)](#)

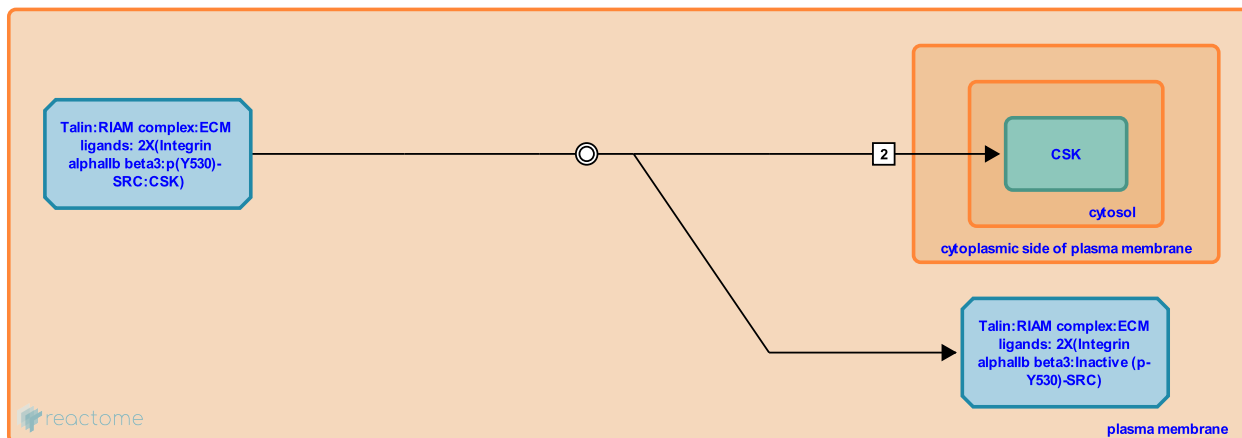

This event has been computationally inferred from an event that has been demonstrated in another species.

The inference is based on the homology mapping from PANTHER. Briefly, reactions for which all involved PhysicalEntities (in input, output and catalyst) have a mapped orthologue/paralogue (for complexes at least 75% of components must have a mapping) are inferred to the other species. High level events are also inferred for these events to allow for easier navigation.

[More details and caveats of the event inference in Reactome.](#) For details on PANTHER see also: <http://www.pantherdb.org/about.jsp>

**Preceded by:** [Clustering of Integrin alphaIIb beta3 complexes](#)

**Followed by:** [Dephosphorylation of inactive SRC by PTPB1](#)

## Dephosphorylation of inactive SRC by PTPB1 ↗

**Location:** [Integrin signaling](#)

**Stable identifier:** R-MMU-377643

**Type:** transition

**Compartments:** plasma membrane, cytosol

**Inferred from:** [Dephosphorylation of inactive SRC by PTPB1 \(Homo sapiens\)](#)

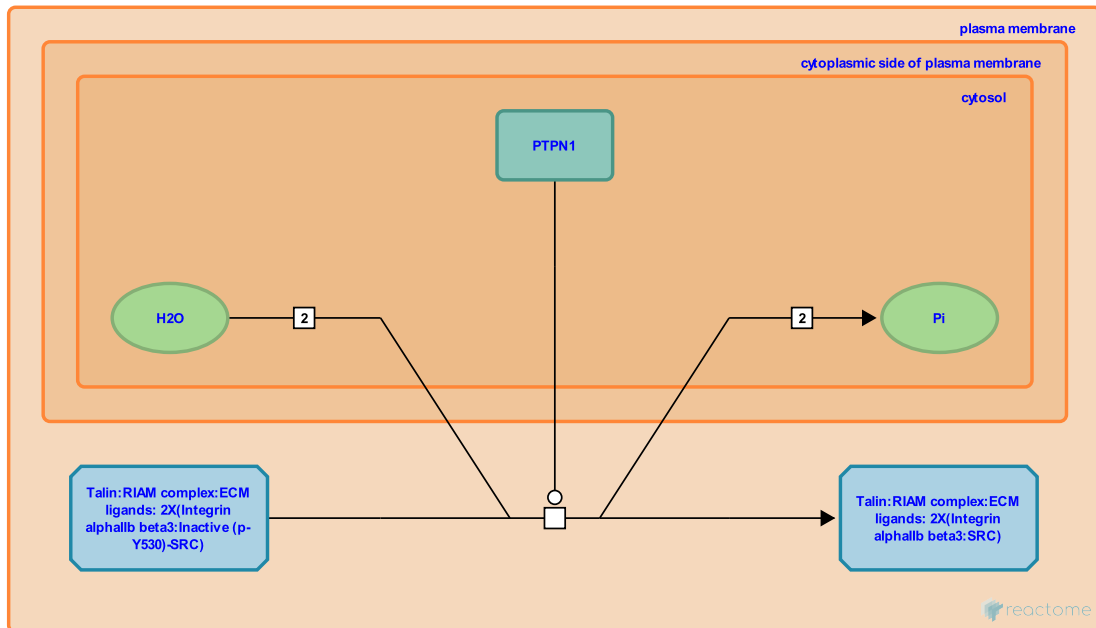

This event has been computationally inferred from an event that has been demonstrated in another species.

The inference is based on the homology mapping from PANTHER. Briefly, reactions for which all involved PhysicalEntities (in input, output and catalyst) have a mapped orthologue/paralogue (for complexes at least 75% of components must have a mapping) are inferred to the other species. High level events are also inferred for these events to allow for easier navigation.

[More details and caveats of the event inference in Reactome.](#) For details on PANTHER see also: <http://www.pantherdb.org/about.jsp>

**Preceded by:** [Release of CSK from SRC](#)

**Followed by:** [Autophosphorylation of SRC](#)

## Autophosphorylation of SRC ↗

**Location:** [Integrin signaling](#)

**Stable identifier:** R-MMU-377640

**Type:** transition

**Compartments:** plasma membrane, cytosol

**Inferred from:** [Autophosphorylation of SRC \(Homo sapiens\)](#)

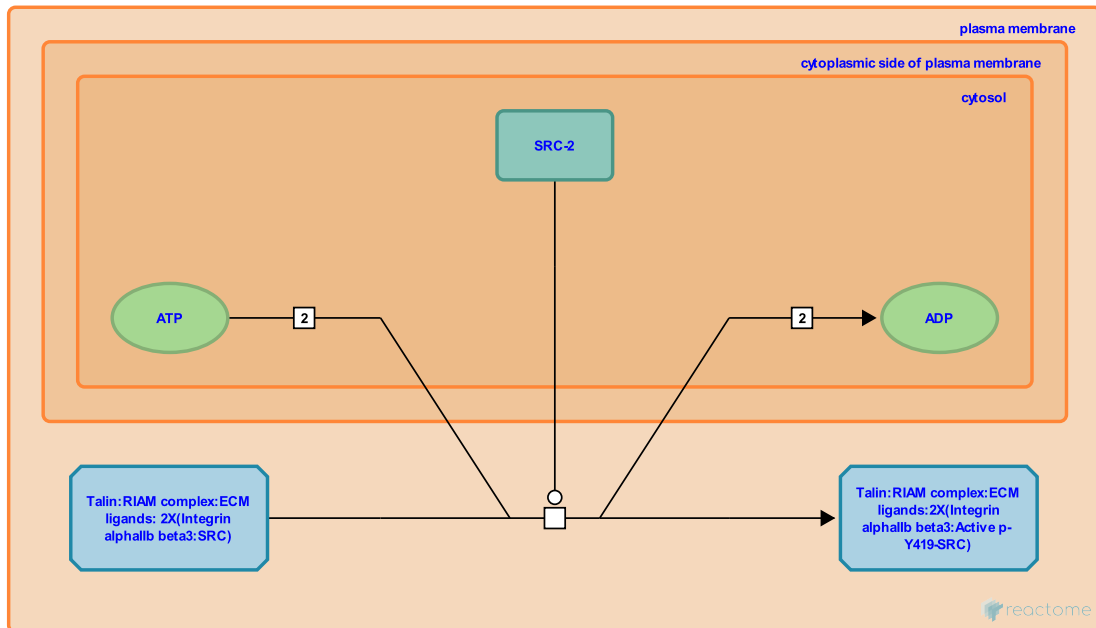

This event has been computationally inferred from an event that has been demonstrated in another species.

The inference is based on the homology mapping from PANTHER. Briefly, reactions for which all involved PhysicalEntities (in input, output and catalyst) have a mapped orthologue/paralogue (for complexes at least 75% of components must have a mapping) are inferred to the other species. High level events are also inferred for these events to allow for easier navigation.

[More details and caveats of the event inference in Reactome.](#) For details on PANTHER see also: <http://www.pantherdb.org/about.jsp>

**Preceded by:** [Dephosphorylation of inactive SRC by PTPB1](#)

**Followed by:** [SYK binds to integrin alphaIIb beta3](#), [Translocation of PTK2 to Focal complexes](#)

## Translocation of PTK2 to Focal complexes ↗

**Location:** [Integrin signaling](#)

**Stable identifier:** R-MMU-354066

**Type:** binding

**Compartments:** plasma membrane, cytosol

**Inferred from:** [Translocation of PTK2 to Focal complexes \(Homo sapiens\)](#)

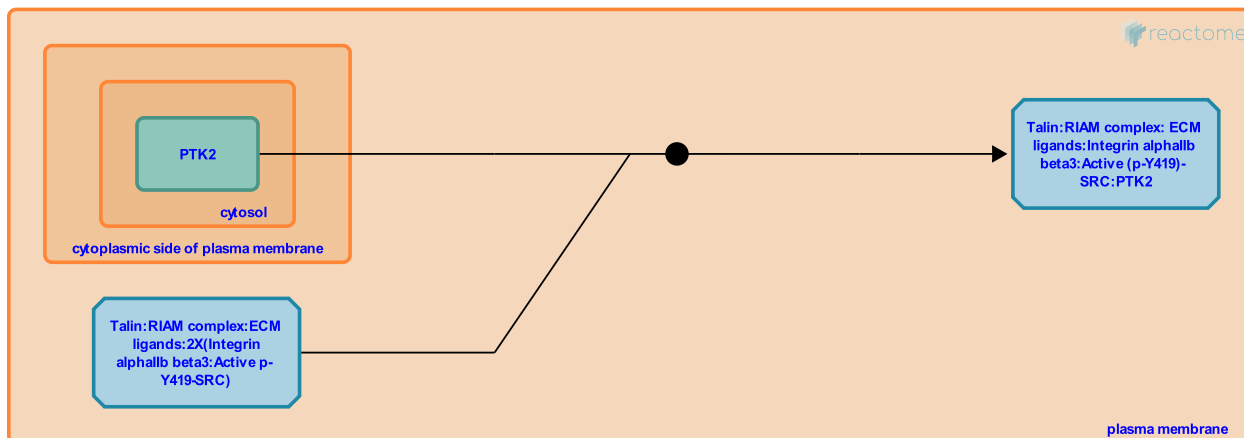

This event has been computationally inferred from an event that has been demonstrated in another species.

The inference is based on the homology mapping from PANTHER. Briefly, reactions for which all involved PhysicalEntities (in input, output and catalyst) have a mapped orthologue/paralogue (for complexes at least 75% of components must have a mapping) are inferred to the other species. High level events are also inferred for these events to allow for easier navigation.

[More details and caveats of the event inference in Reactome.](#) For details on PANTHER see also: <http://www.pantherdb.org/about.jsp>

**Preceded by:** [Autophosphorylation of SRC](#)

**Followed by:** [Autophosphorylation of PTK2 at Y397](#)

## Autophosphorylation of PTK2 at Y397 ↗

**Location:** [Integrin signaling](#)

**Stable identifier:** R-MMU-354073

**Type:** transition

**Compartments:** plasma membrane, cytosol

**Inferred from:** [Autophosphorylation of PTK2 at Y397 \(Homo sapiens\)](#)

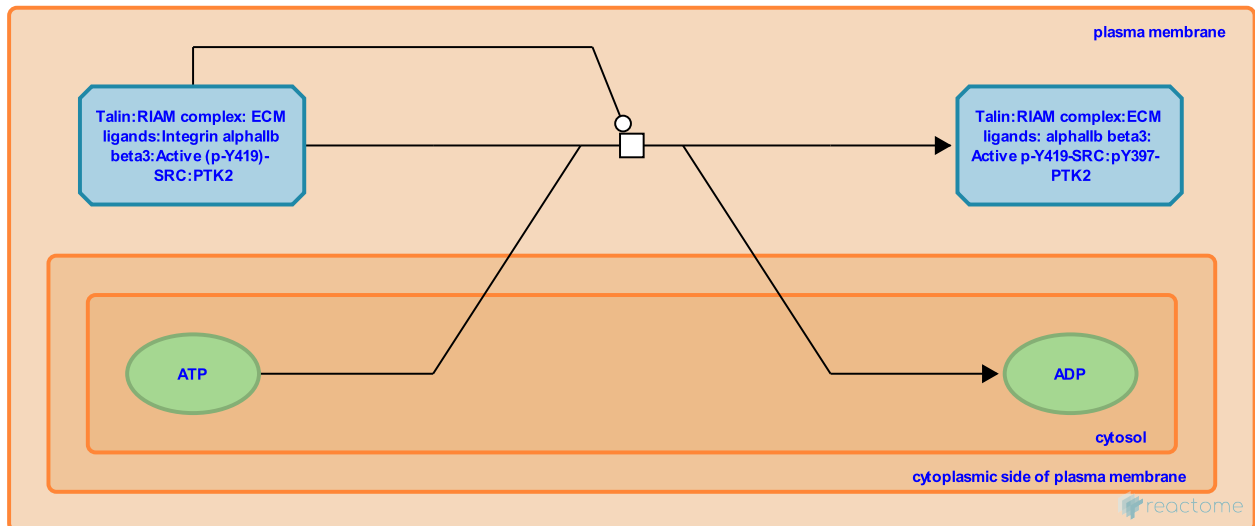

This event has been computationally inferred from an event that has been demonstrated in another species.

The inference is based on the homology mapping from PANTHER. Briefly, reactions for which all involved PhysicalEntities (in input, output and catalyst) have a mapped orthologue/paralogue (for complexes at least 75% of components must have a mapping) are inferred to the other species. High level events are also inferred for these events to allow for easier navigation.

[More details and caveats of the event inference in Reactome.](#) For details on PANTHER see also: <http://www.pantherdb.org/about.jsp>

**Preceded by:** [Translocation of PTK2 to Focal complexes](#)

**Followed by:** [Phosphorylation of pPTK2 by SRC](#)

## Phosphorylation of pPTK2 by SRC ↗

**Location:** [Integrin signaling](#)

**Stable identifier:** R-MMU-354124

**Type:** transition

**Compartments:** plasma membrane, cytosol

**Inferred from:** [Phosphorylation of pPTK2 by SRC \(Homo sapiens\)](#)

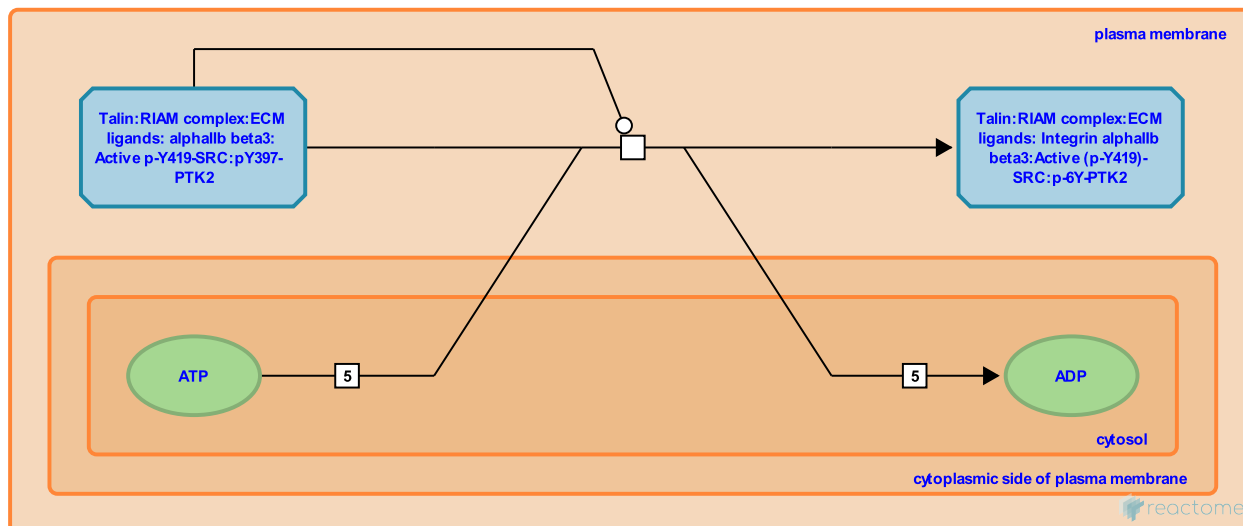

This event has been computationally inferred from an event that has been demonstrated in another species.

The inference is based on the homology mapping from PANTHER. Briefly, reactions for which all involved PhysicalEntities (in input, output and catalyst) have a mapped orthologue/paralogue (for complexes at least 75% of components must have a mapping) are inferred to the other species. High level events are also inferred for these events to allow for easier navigation.

[More details and caveats of the event inference in Reactome.](#) For details on PANTHER see also: <http://www.pantherdb.org/about.jsp>

**Preceded by:** [Autophosphorylation of PTK2 at Y397](#)



## GRB2:SOS provides linkage to MAPK signaling for Integrins ↗

**Location:** [Integrin signaling](#)

**Stable identifier:** R-MMU-354194

**Inferred from:** [GRB2:SOS provides linkage to MAPK signaling for Integrins \(Homo sapiens\)](#)

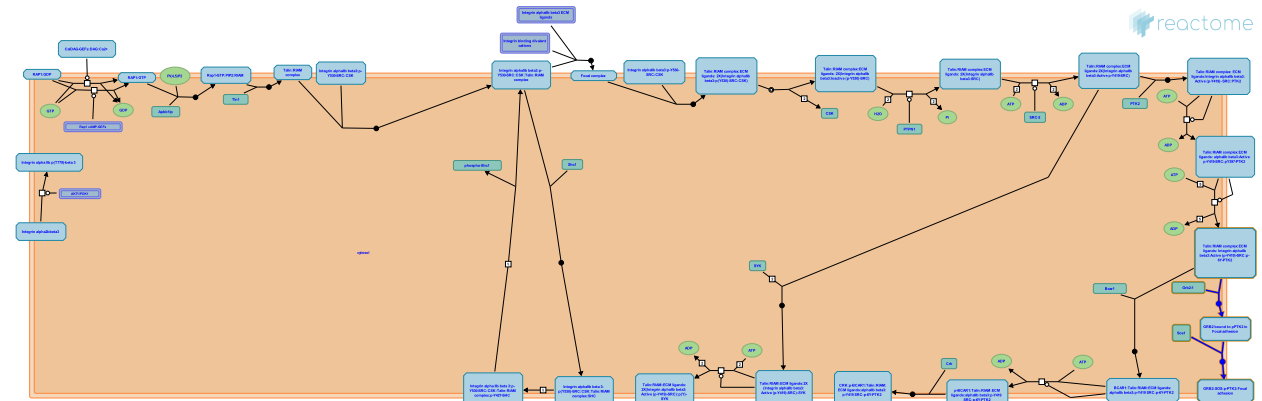

This event has been computationally inferred from an event that has been demonstrated in another species.

The inference is based on the homology mapping from PANTHER. Briefly, reactions for which all involved PhysicalEntities (in input, output and catalyst) have a mapped orthologue/paralogue (for complexes at least 75% of components must have a mapping) are inferred to the other species. High level events are also inferred for these events to allow for easier navigation.

[More details and caveats of the event inference in Reactome.](#) For details on PANTHER see also: <http://www.pantherdb.org/about.jsp>

## p130Cas linkage to MAPK signaling for integrins ↗

**Location:** [Integrin signaling](#)

**Stable identifier:** R-MMU-372708

**Inferred from:** [p130Cas linkage to MAPK signaling for integrins \(Homo sapiens\)](#)

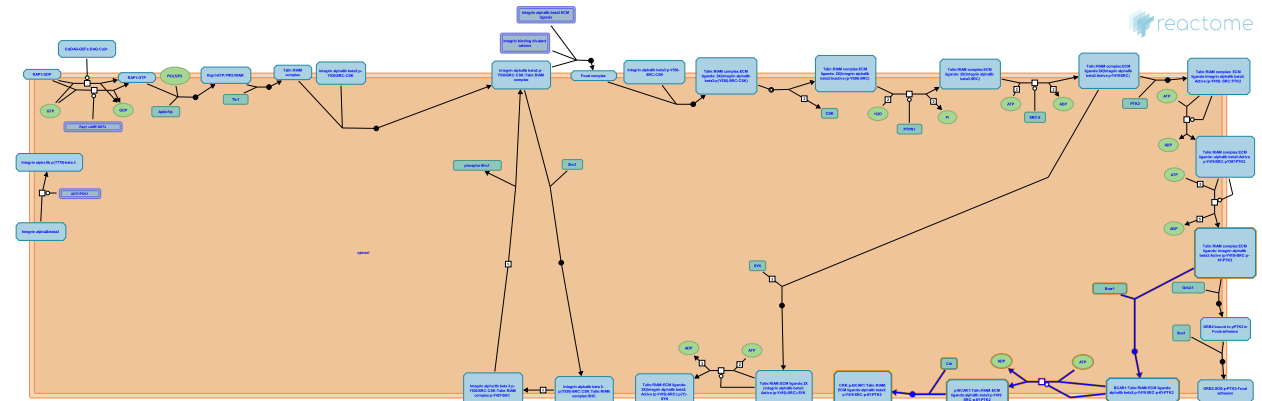

This event has been computationally inferred from an event that has been demonstrated in another species.

The inference is based on the homology mapping from PANTHER. Briefly, reactions for which all involved PhysicalEntities (in input, output and catalyst) have a mapped orthologue/paralogue (for complexes at least 75% of components must have a mapping) are inferred to the other species. High level events are also inferred for these events to allow for easier navigation.

[More details and caveats of the event inference in Reactome.](#) For details on PANTHER see also: <http://www.pantherdb.org/about.jsp>

## Integrin alpha Iib beta3 T779 phosphorylation blocks SHC binding ↗

**Location:** [Integrin signaling](#)

**Stable identifier:** R-MMU-432110

**Type:** transition

**Compartments:** plasma membrane

**Inferred from:** [Integrin alpha Iib beta3 T779 phosphorylation blocks SHC binding \(Homo sapiens\)](#)

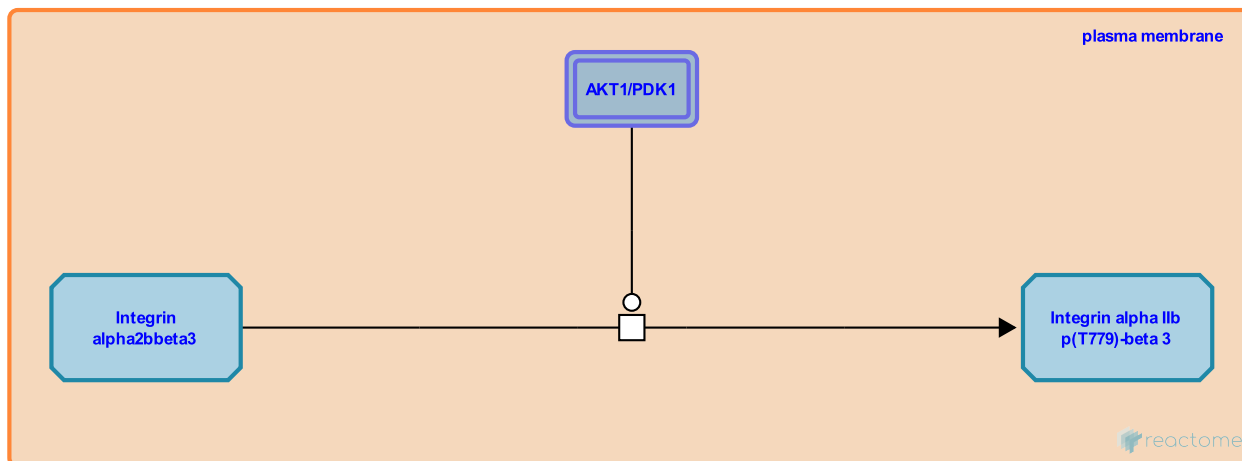

This event has been computationally inferred from an event that has been demonstrated in another species.

The inference is based on the homology mapping from PANTHER. Briefly, reactions for which all involved PhysicalEntities (in input, output and catalyst) have a mapped orthologue/paralogue (for complexes at least 75% of components must have a mapping) are inferred to the other species. High level events are also inferred for these events to allow for easier navigation.

[More details and caveats of the event inference in Reactome.](#) For details on PANTHER see also: <http://www.pantherdb.org/about.jsp>

**Followed by:** [Activated integrin alphaIib beta3 binds SHC1](#)

## Activated integrin alphaIIb beta3 binds SHC1 [↗](#)

**Location:** [Integrin signaling](#)

**Stable identifier:** R-MMU-432096

**Type:** binding

**Compartments:** plasma membrane, cytosol

**Inferred from:** [Activated integrin alphaIIb beta3 binds SHC1 \(Homo sapiens\)](#)

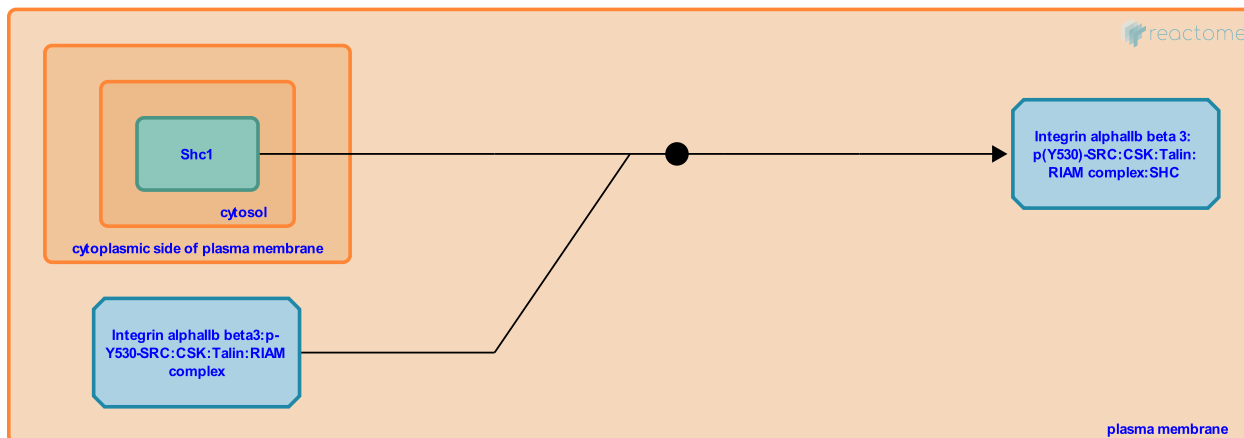

This event has been computationally inferred from an event that has been demonstrated in another species.

The inference is based on the homology mapping from PANTHER. Briefly, reactions for which all involved PhysicalEntities (in input, output and catalyst) have a mapped orthologue/paralogue (for complexes at least 75% of components must have a mapping) are inferred to the other species. High level events are also inferred for these events to allow for easier navigation.

[More details and caveats of the event inference in Reactome.](#) For details on PANTHER see also: <http://www.pantherdb.org/about.jsp>

**Preceded by:** [Integrin alpha IIb beta3 T779 phosphorylation blocks SHC binding](#), [Integrin alphaIIb beta3 activation](#)

**Followed by:** [SHC1 bound to integrin alphaIIb beta3 is phosphorylated somehow](#)

## SHC1 bound to integrin alphaIIb beta3 is phosphorylated somehow ↗

**Location:** [Integrin signaling](#)

**Stable identifier:** R-MMU-443905

**Type:** omitted

**Compartments:** plasma membrane

**Inferred from:** [SHC1 bound to integrin alphaIIb beta3 is phosphorylated somehow \(Homo sapiens\)](#)

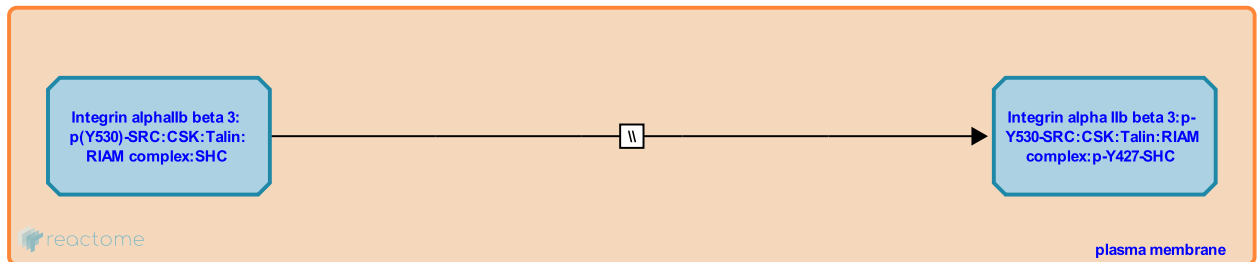

This event has been computationally inferred from an event that has been demonstrated in another species.

The inference is based on the homology mapping from PANTHER. Briefly, reactions for which all involved PhysicalEntities (in input, output and catalyst) have a mapped orthologue/paralogue (for complexes at least 75% of components must have a mapping) are inferred to the other species. High level events are also inferred for these events to allow for easier navigation.

[More details and caveats of the event inference in Reactome.](#) For details on PANTHER see also: <http://www.pantherdb.org/about.jsp>

**Preceded by:** [Activated integrin alphaIIb beta3 binds SHC1](#)

**Followed by:** [SHC1 dissociates from integrin alphaIIb beta3](#)

## SHC1 dissociates from integrin alphaIIb beta3 ↗

**Location:** [Integrin signaling](#)

**Stable identifier:** R-MMU-443910

**Type:** omitted

**Compartments:** plasma membrane

**Inferred from:** [SHC1 dissociates from integrin alphaIIb beta3 \(Homo sapiens\)](#)

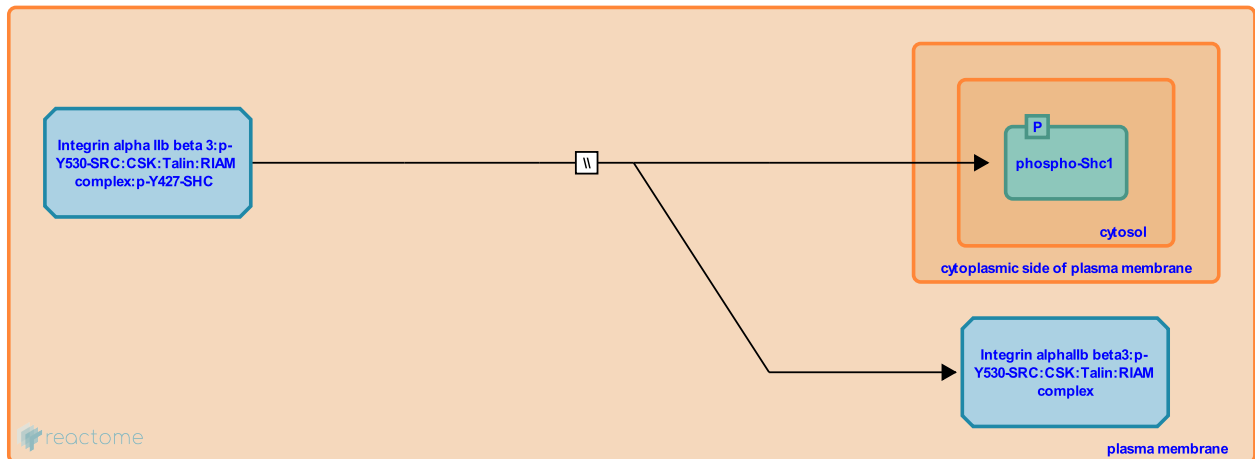

This event has been computationally inferred from an event that has been demonstrated in another species.

The inference is based on the homology mapping from PANTHER. Briefly, reactions for which all involved PhysicalEntities (in input, output and catalyst) have a mapped orthologue/paralogue (for complexes at least 75% of components must have a mapping) are inferred to the other species. High level events are also inferred for these events to allow for easier navigation.

[More details and caveats of the event inference in Reactome.](#) For details on PANTHER see also: <http://www.pantherdb.org/about.jsp>

**Preceded by:** [SHC1 bound to integrin alphaIIb beta3 is phosphorylated somehow](#)

## SYK binds to integrin alphaIIb beta3 ↗

**Location:** [Integrin signaling](#)

**Stable identifier:** R-MMU-429415

**Type:** binding

**Compartments:** plasma membrane, cytosol

**Inferred from:** [SYK binds to integrin alphaIIb beta3 \(Homo sapiens\)](#)

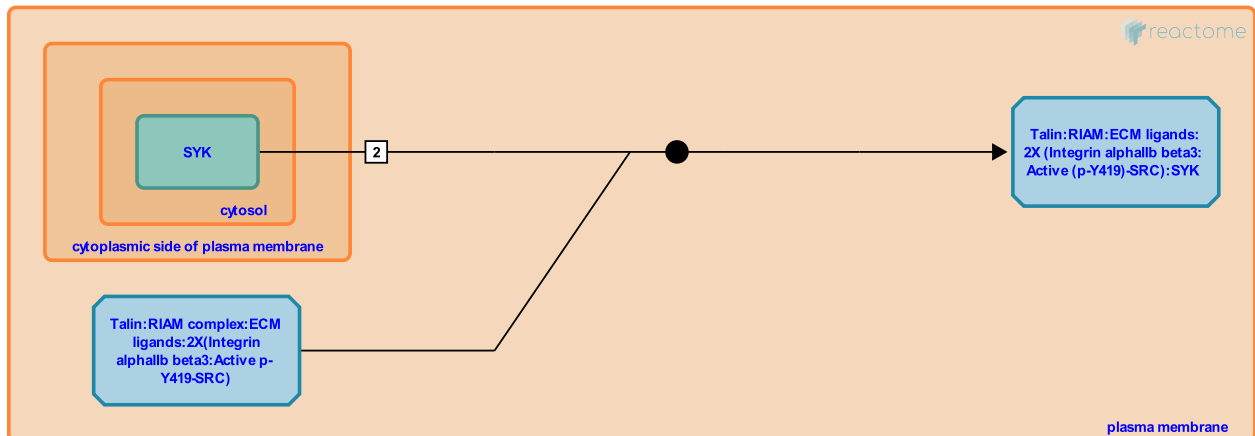

This event has been computationally inferred from an event that has been demonstrated in another species.

The inference is based on the homology mapping from PANTHER. Briefly, reactions for which all involved PhysicalEntities (in input, output and catalyst) have a mapped orthologue/paralogue (for complexes at least 75% of components must have a mapping) are inferred to the other species. High level events are also inferred for these events to allow for easier navigation.

[More details and caveats of the event inference in Reactome.](#) For details on PANTHER see also: <http://www.pantherdb.org/about.jsp>

**Preceded by:** [Autophosphorylation of SRC](#)

**Followed by:** [SYK activation by SRC](#)

## SYK activation by SRC ↗

**Location:** [Integrin signaling](#)

**Stable identifier:** R-MMU-429441

**Type:** transition

**Compartments:** plasma membrane, cytosol

**Inferred from:** [SYK activation by SRC \(Homo sapiens\)](#)

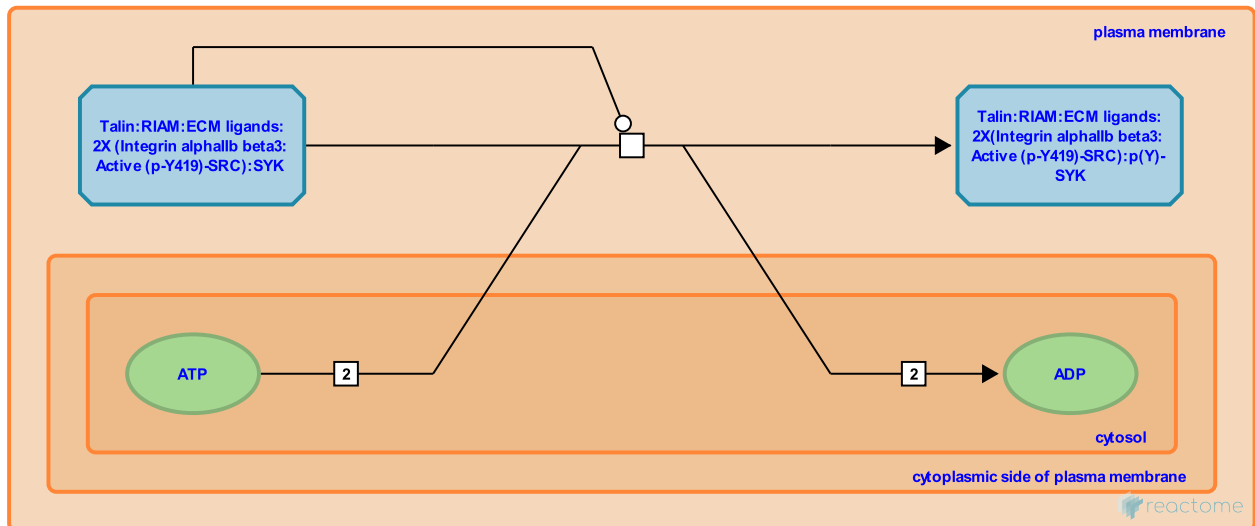

This event has been computationally inferred from an event that has been demonstrated in another species.

The inference is based on the homology mapping from PANTHER. Briefly, reactions for which all involved PhysicalEntities (in input, output and catalyst) have a mapped orthologue/paralogue (for complexes at least 75% of components must have a mapping) are inferred to the other species. High level events are also inferred for these events to allow for easier navigation.

[More details and caveats of the event inference in Reactome.](#) For details on PANTHER see also: <http://www.pantherdb.org/about.jsp>

**Preceded by:** [SYK binds to integrin alphaIIb beta3](#)



# Table of Contents

Introduction	1
☰ Integrin signaling	2
↳ Activation of Rap1 by cytosolic GEFs	3
↳ Activation of Rap1 by membrane-associated GEFs	4
↳ Translocation of RIAM to plasma membrane	5
↳ Activation of Talin	6
↳ Integrin alphaIIb beta3 activation	7
↳ Interaction of integrin alphaIIb beta3 with Fibrinogen	8
↳ Clustering of Integrin alphaIIb beta3 complexes	9
↳ Release of CSK from SRC	10
↳ Dephosphorylation of inactive SRC by PTPB1	11
↳ Autophosphorylation of SRC	12
↳ Translocation of PTK2 to Focal complexes	13
↳ Autophosphorylation of PTK2 at Y397	14
↳ Phosphorylation of pPTK2 by SRC	15
☰ GRB2:SOS provides linkage to MAPK signaling for Integrins	16
☰ p130Cas linkage to MAPK signaling for integrins	17
↳ Integrin alpha IIb beta3 T779 phosphorylation blocks SHC binding	18
↳ Activated integrin alphaIIb beta3 binds SHC1	19
↳ SHC1 bound to integrin alphaIIb beta3 is phosphorylated somehow	20
↳ SHC1 dissociates from integrin alphaIIb beta3	21
↳ SYK binds to integrin alphaIIb beta3	22
↳ SYK activation by SRC	23
Table of Contents	24