

Generation of second messenger molecules

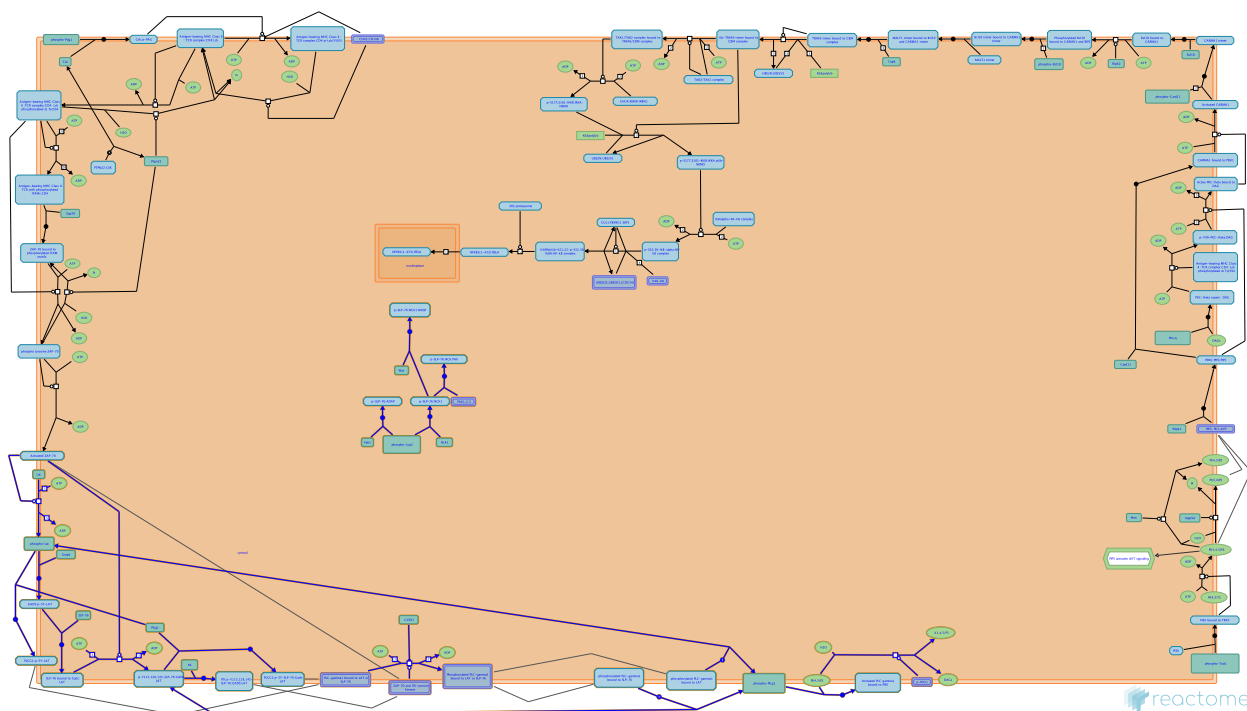

European Bioinformatics Institute, New York University Langone Medical Center, Ontario Institute for Cancer Research, Oregon Health and Science University.

The contents of this document may be freely copied and distributed in any media, provided the authors, plus the institutions, are credited, as stated under the terms of [Creative Commons Attribution 4.0 International \(CC BY 4.0\) License](#). For more information see our [license](#).

Introduction

Reactome is open-source, open access, manually curated and peer-reviewed pathway database. Pathway annotations are authored by expert biologists, in collaboration with Reactome editorial staff and cross-referenced to many bioinformatics databases. A system of evidence tracking ensures that all assertions are backed up by the primary literature. Reactome is used by clinicians, geneticists, genomics researchers, and molecular biologists to interpret the results of high-throughput experimental studies, by bioinformaticians seeking to develop novel algorithms for mining knowledge from genomic studies, and by systems biologists building predictive models of normal and disease variant pathways.

The development of Reactome is supported by grants from the US National Institutes of Health (P41 HG003751), University of Toronto (CFREF Medicine by Design), European Union (EU STRP, EMI-CD), and the European Molecular Biology Laboratory (EBI Industry program).

Literature references

- Fabregat, A., Sidiropoulos, K., Viteri, G., Forner, O., Marin-Garcia, P., Arnau, V. et al. (2017). Reactome pathway analysis: a high-performance in-memory approach. *BMC bioinformatics*, 18, 142. [↗](#)
- Sidiropoulos, K., Viteri, G., Sevilla, C., Jupe, S., Webber, M., Orlic-Milacic, M. et al. (2017). Reactome enhanced pathway visualization. *Bioinformatics*, 33, 3461-3467. [↗](#)
- Fabregat, A., Jupe, S., Matthews, L., Sidiropoulos, K., Gillespie, M., Garapati, P. et al. (2018). The Reactome Pathway Knowledgebase. *Nucleic Acids Res*, 46, D649-D655. [↗](#)
- Fabregat, A., Korninger, F., Viteri, G., Sidiropoulos, K., Marin-Garcia, P., Ping, P. et al. (2018). Reactome graph database: Efficient access to complex pathway data. *PLoS computational biology*, 14, e1005968. [↗](#)

Reactome database release: 77

This document contains 1 pathway and 16 reactions ([see Table of Contents](#))

Generation of second messenger molecules ↗

Stable identifier: R-MMU-202433

Compartments: plasma membrane

Inferred from: [Generation of second messenger molecules \(Homo sapiens\)](#)

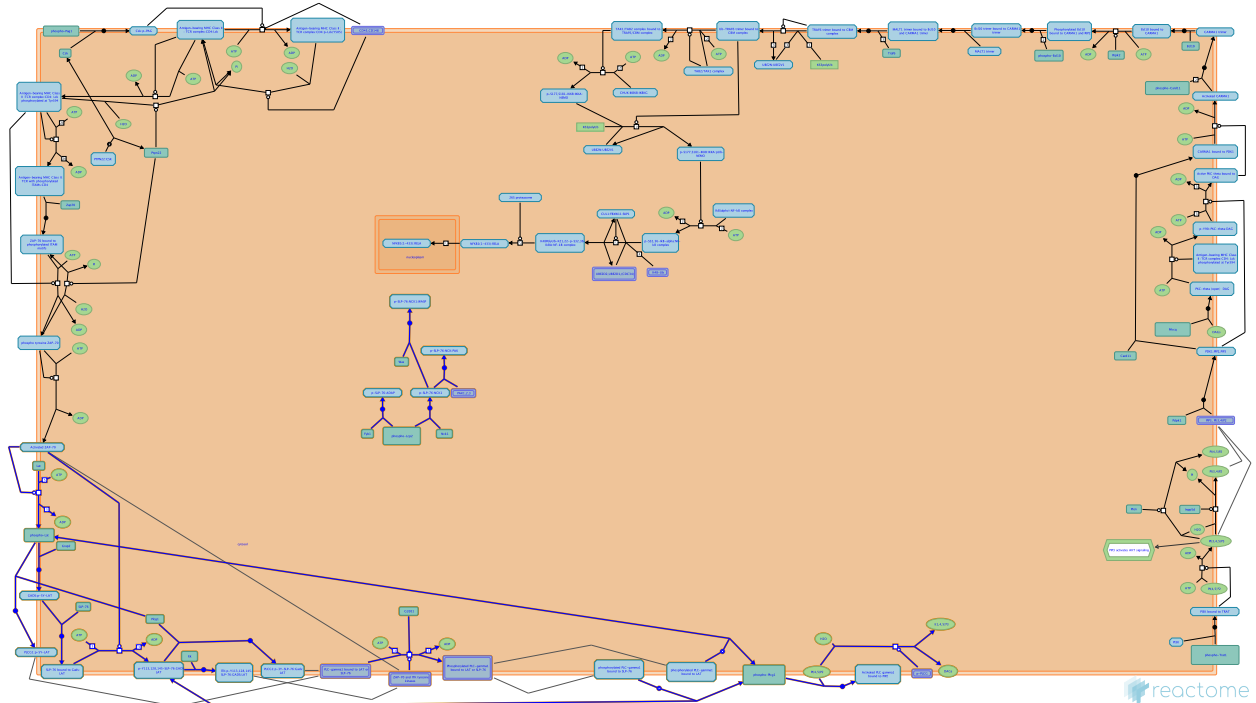

This event has been computationally inferred from an event that has been demonstrated in another species.

The inference is based on the homology mapping from PANTHER. Briefly, reactions for which all involved PhysicalEntities (in input, output and catalyst) have a mapped orthologue/paralogue (for complexes at least 75% of components must have a mapping) are inferred to the other species. High level events are also inferred for these events to allow for easier navigation.

[More details and caveats of the event inference in Reactome.](/electronic_inference_compara.html) For details on PANTHER see also: <http://www.pantherdb.org/about.jsp>

Recruitment of Gads to LAT ↗

Location: [Generation of second messenger molecules](#)

Stable identifier: R-MMU-202325

Type: binding

Compartments: cytosol, plasma membrane

Inferred from: [Recruitment of Gads to LAT \(Homo sapiens\)](#)

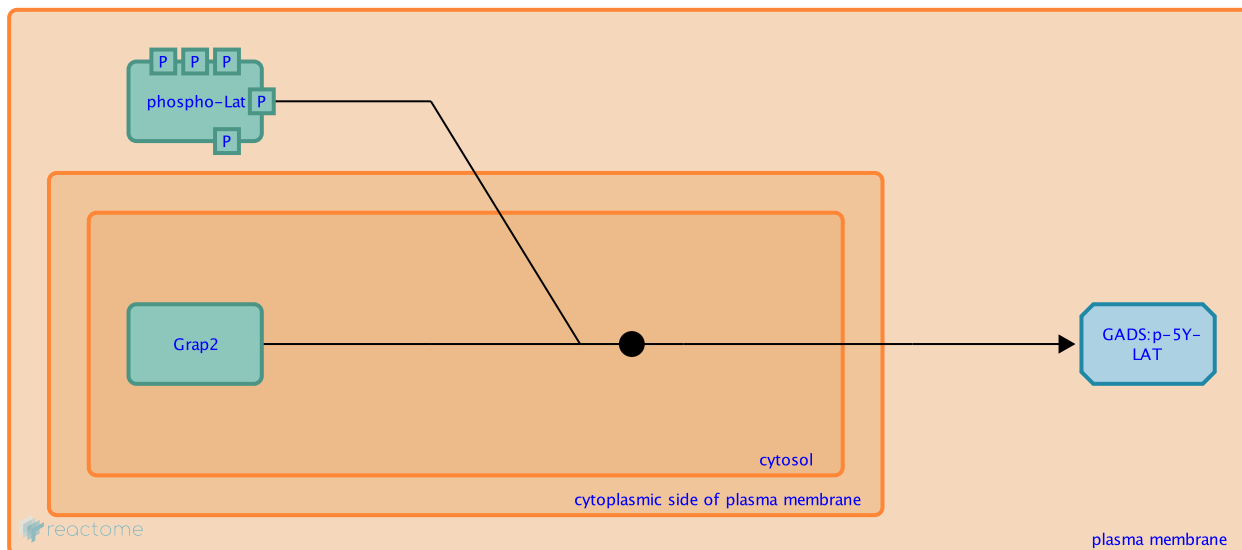

This event has been computationally inferred from an event that has been demonstrated in another species.

The inference is based on the homology mapping from PANTHER. Briefly, reactions for which all involved PhysicalEntities (in input, output and catalyst) have a mapped orthologue/paralogue (for complexes at least 75% of components must have a mapping) are inferred to the other species. High level events are also inferred for these events to allow for easier navigation.

[More details and caveats of the event inference in Reactome.](/electronic_inference_compara.html) For details on PANTHER see also: <http://www.pantherdb.org/about.jsp>

Preceded by: [Phosphorylation of TBSMs in LAT](#)

Followed by: [Recruitment of SLP-76 to Gads](#)

Recruitment of SLP-76 to Gads [↗](#)

Location: [Generation of second messenger molecules](#)

Stable identifier: R-MMU-202241

Type: binding

Compartments: cytosol, plasma membrane

Inferred from: [Recruitment of SLP-76 to Gads \(Homo sapiens\)](#)

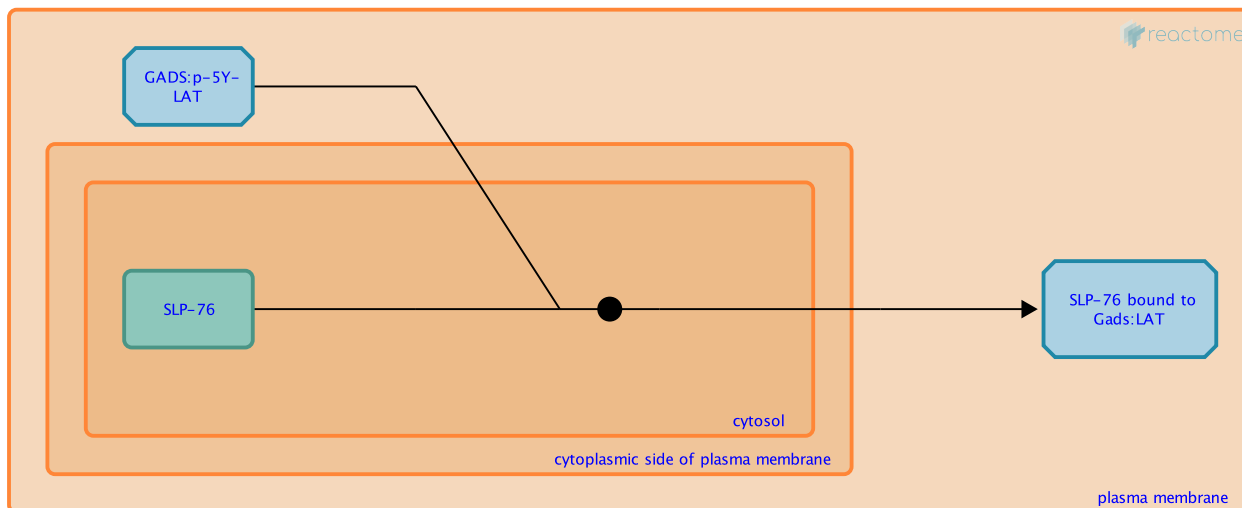

This event has been computationally inferred from an event that has been demonstrated in another species.

The inference is based on the homology mapping from PANTHER. Briefly, reactions for which all involved PhysicalEntities (in input, output and catalyst) have a mapped orthologue/paralogue (for complexes at least 75% of components must have a mapping) are inferred to the other species. High level events are also inferred for these events to allow for easier navigation.

[More details and caveats of the event inference in Reactome.](/electronic_inference_compara.html) For details on PANTHER see also: <http://www.pantherdb.org/about.jsp>

Preceded by: [Recruitment of Gads to LAT](#)

Followed by: [Phosphorylation of SLP-76](#)

Phosphorylation of SLP-76 ↗

Location: [Generation of second messenger molecules](#)

Stable identifier: R-MMU-202216

Type: transition

Compartments: cytosol, plasma membrane

Inferred from: [Phosphorylation of SLP-76 \(Homo sapiens\)](#)

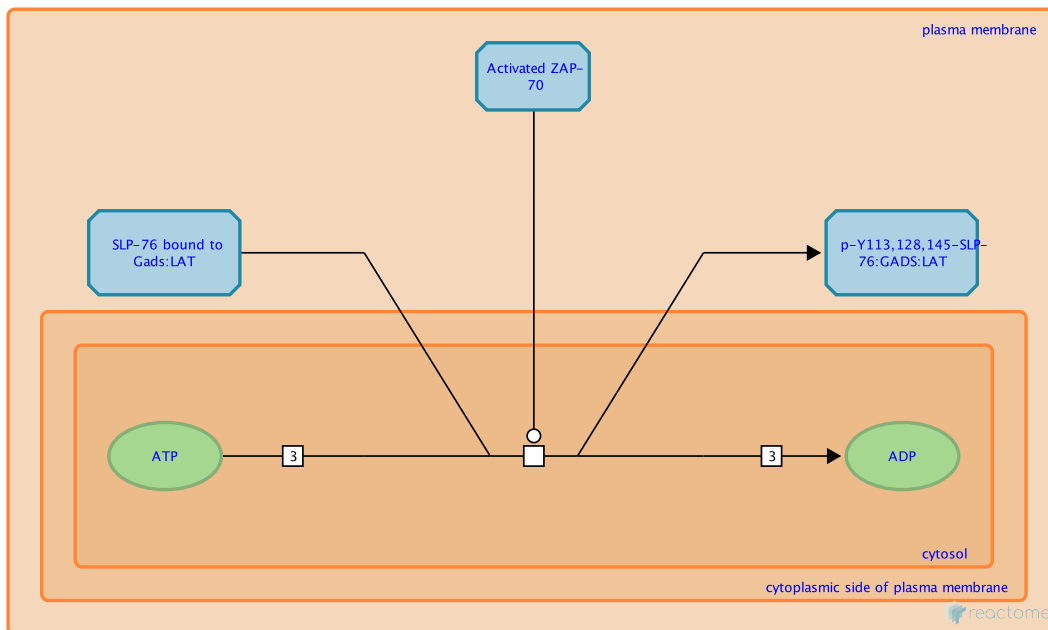

This event has been computationally inferred from an event that has been demonstrated in another species.

The inference is based on the homology mapping from PANTHER. Briefly, reactions for which all involved PhysicalEntities (in input, output and catalyst) have a mapped orthologue/paralogue (for complexes at least 75% of components must have a mapping) are inferred to the other species. High level events are also inferred for these events to allow for easier navigation.

[More details and caveats of the event inference in Reactome.](/electronic_inference_compara.html) For details on PANTHER see also: <http://www.pantherdb.org/about.jsp>

Preceded by: [Recruitment of SLP-76 to Gads](#)

Followed by: [p-SLP-76 binds ADAP](#), [Recruitment of ITK to SLP-76](#), [Recruitment of PLC-gamma1 to SLP-76](#)

Recruitment of ITK to SLP-76 [↗](#)

Location: [Generation of second messenger molecules](#)

Stable identifier: R-MMU-202375

Type: binding

Compartments: plasma membrane, cytosol

Inferred from: [Recruitment of ITK to SLP-76 \(Homo sapiens\)](#)

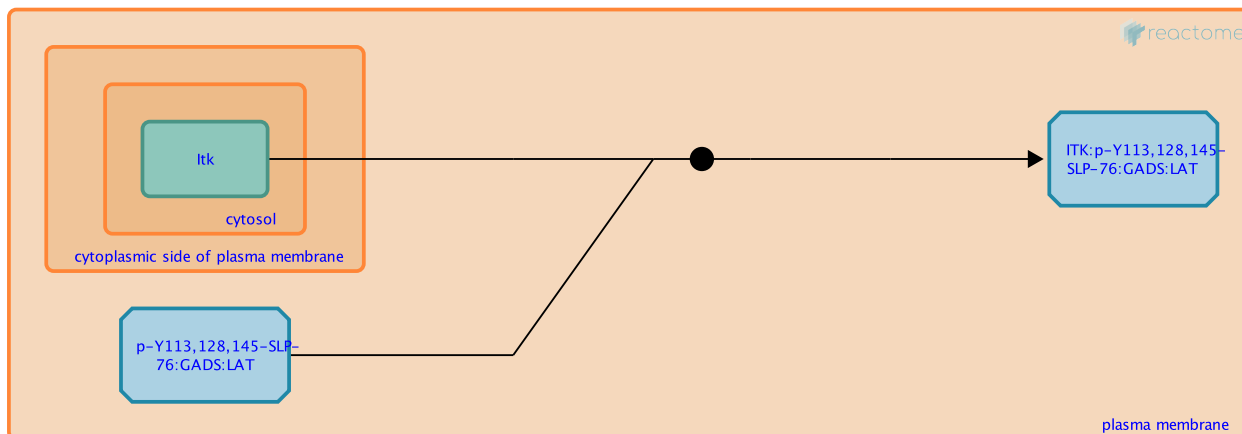

This event has been computationally inferred from an event that has been demonstrated in another species.

The inference is based on the homology mapping from PANTHER. Briefly, reactions for which all involved PhysicalEntities (in input, output and catalyst) have a mapped orthologue/paralogue (for complexes at least 75% of components must have a mapping) are inferred to the other species. High level events are also inferred for these events to allow for easier navigation.

[More details and caveats of the event inference in Reactome.](/electronic_inference_compara.html) For details on PANTHER see also: <http://www.pantherdb.org/about.jsp>

Preceded by: [Phosphorylation of SLP-76](#)

Followed by: [Phosphorylation of PLC-gamma1](#)

Recruitment of PLC-gamma1 to SLP-76 ↗

Location: [Generation of second messenger molecules](#)

Stable identifier: R-MMU-202331

Type: binding

Compartments: cytosol, plasma membrane

Inferred from: [Recruitment of PLC-gamma1 to SLP-76 \(Homo sapiens\)](#)

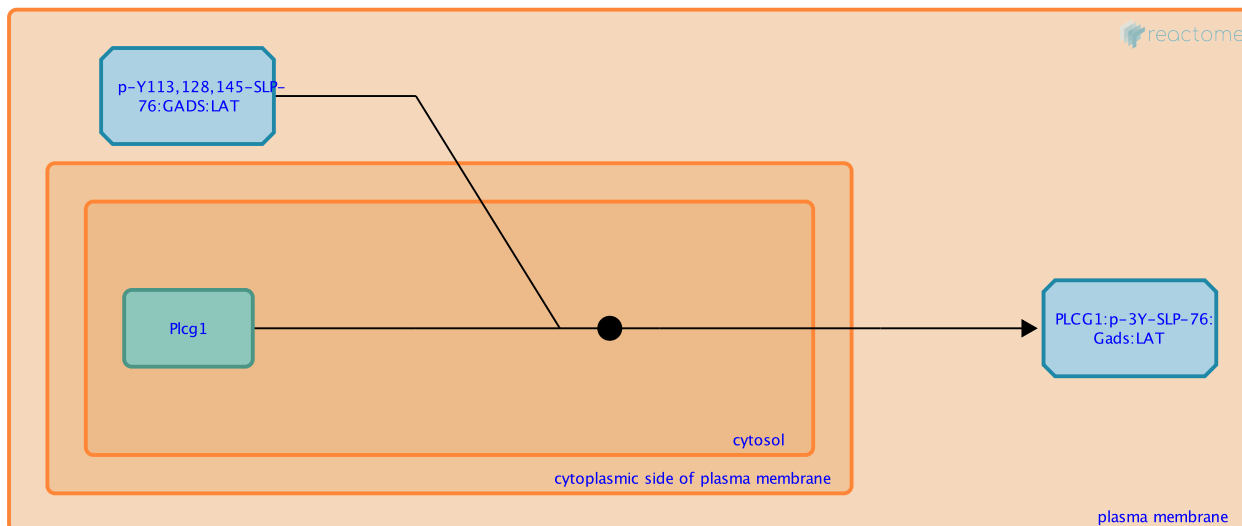

This event has been computationally inferred from an event that has been demonstrated in another species.

The inference is based on the homology mapping from PANTHER. Briefly, reactions for which all involved PhysicalEntities (in input, output and catalyst) have a mapped orthologue/paralogue (for complexes at least 75% of components must have a mapping) are inferred to the other species. High level events are also inferred for these events to allow for easier navigation.

[More details and caveats of the event inference in Reactome.](/electronic_inference_compara.html) For details on PANTHER see also: <http://www.pantherdb.org/about.jsp>

Preceded by: [Phosphorylation of SLP-76](#)

Followed by: [Phosphorylation of PLC-gamma1](#)

Recruitment of PLC-gamma1 to LAT ↗

Location: [Generation of second messenger molecules](#)

Stable identifier: R-MMU-202212

Type: binding

Compartments: cytosol, plasma membrane

Inferred from: [Recruitment of PLC-gamma1 to LAT \(Homo sapiens\)](#)

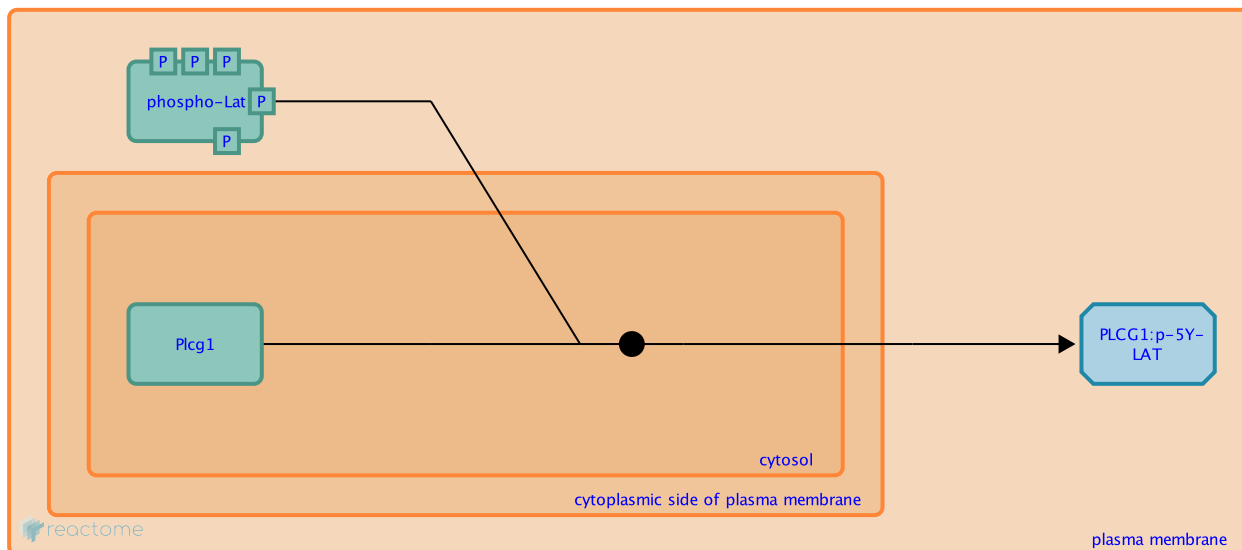

This event has been computationally inferred from an event that has been demonstrated in another species.

The inference is based on the homology mapping from PANTHER. Briefly, reactions for which all involved PhysicalEntities (in input, output and catalyst) have a mapped orthologue/paralogue (for complexes at least 75% of components must have a mapping) are inferred to the other species. High level events are also inferred for these events to allow for easier navigation.

[More details and caveats of the event inference in Reactome.](/electronic_inference_compara.html) For details on PANTHER see also: <http://www.pantherdb.org/about.jsp>

Preceded by: [Phosphorylation of TBSMs in LAT](#)

Followed by: [Phosphorylation of PLC-gamma1](#)

Phosphorylation of PLC-gamma1 ↗

Location: [Generation of second messenger molecules](#)

Stable identifier: R-MMU-202248

Type: transition

Compartments: cytosol, plasma membrane

Inferred from: [Phosphorylation of PLC-gamma1 \(Homo sapiens\)](#)

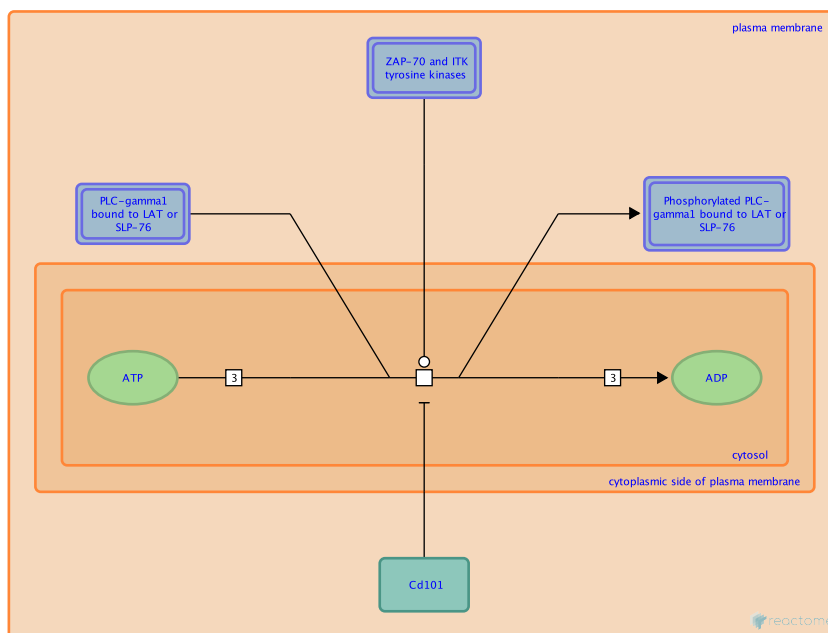

This event has been computationally inferred from an event that has been demonstrated in another species.

The inference is based on the homology mapping from PANTHER. Briefly, reactions for which all involved PhysicalEntities (in input, output and catalyst) have a mapped orthologue/paralogue (for complexes at least 75% of components must have a mapping) are inferred to the other species. High level events are also inferred for these events to allow for easier navigation.

[More details and caveats of the event inference in Reactome](/electronic_inference_compara.html). For details on PANTHER see also: <http://www.pantherdb.org/about.jsp>

Preceded by: [Recruitment of PLC-gamma1 to SLP-76](#), [Recruitment of PLC-gamma1 to LAT](#), [Recruitment of ITK to SLP-76](#)

Followed by: [Disassociation of PLC-gamma1 from LAT](#), [Disassociation of PLC-gamma1 from SLP-76](#), [Translocation of PLC-gamma1 to PIP2](#)

Disassociation of PLC-gamma1 from LAT ↗

Location: [Generation of second messenger molecules](#)

Stable identifier: R-MMU-213406

Type: dissociation

Compartments: cytosol, plasma membrane

Inferred from: [Disassociation of PLC-gamma1 from LAT \(Homo sapiens\)](#)

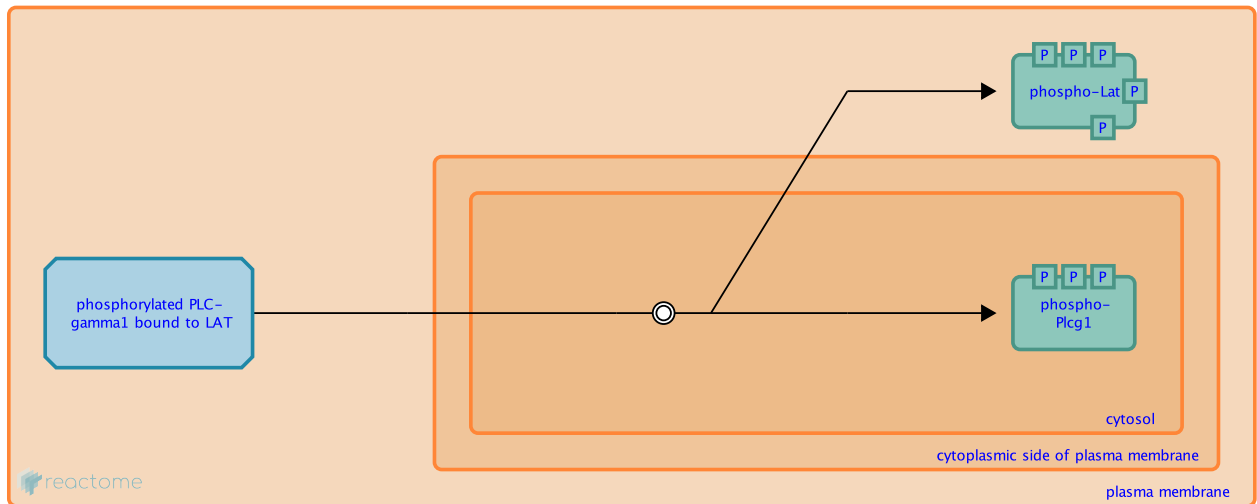

This event has been computationally inferred from an event that has been demonstrated in another species.

The inference is based on the homology mapping from PANTHER. Briefly, reactions for which all involved PhysicalEntities (in input, output and catalyst) have a mapped orthologue/paralogue (for complexes at least 75% of components must have a mapping) are inferred to the other species. High level events are also inferred for these events to allow for easier navigation.

[More details and caveats of the event inference in Reactome.](/electronic_inference_compara.html) For details on PANTHER see also: <http://www.pantherdb.org/about.jsp>

Preceded by: [Phosphorylation of PLC-gamma1](#)

Followed by: [Translocation of PLC-gamma1 to PIP2](#)

Disassociation of PLC-gamma1 from SLP-76 ↗

Location: [Generation of second messenger molecules](#)

Stable identifier: R-MMU-213407

Type: dissociation

Compartments: cytosol, plasma membrane

Inferred from: [Disassociation of PLC-gamma1 from SLP-76 \(Homo sapiens\)](#)

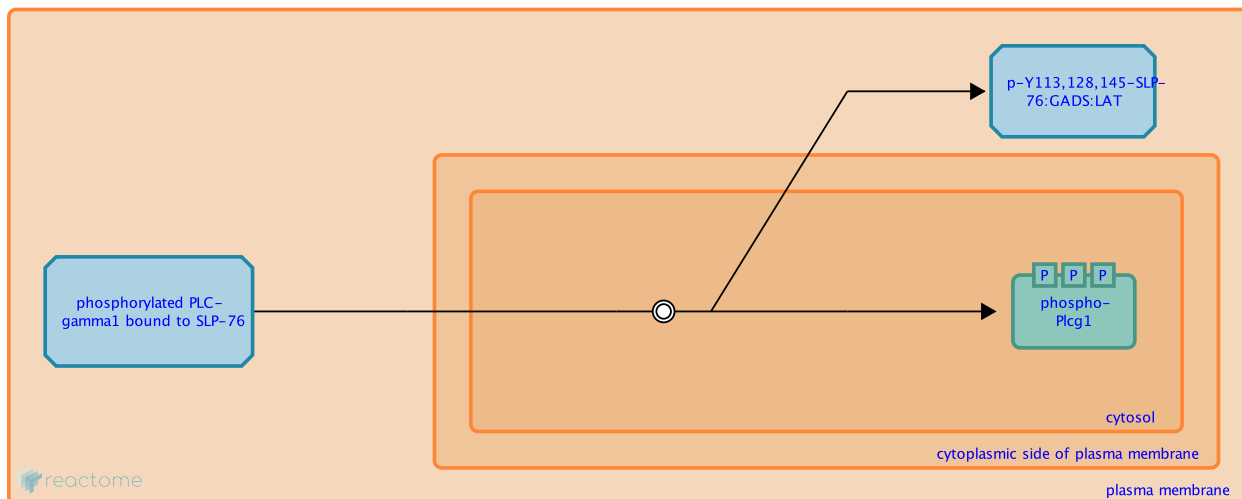

This event has been computationally inferred from an event that has been demonstrated in another species.

The inference is based on the homology mapping from PANTHER. Briefly, reactions for which all involved PhysicalEntities (in input, output and catalyst) have a mapped orthologue/paralogue (for complexes at least 75% of components must have a mapping) are inferred to the other species. High level events are also inferred for these events to allow for easier navigation.

[More details and caveats of the event inference in Reactome.](/electronic_inference_compara.html) For details on PANTHER see also: <http://www.pantherdb.org/about.jsp>

Preceded by: [Phosphorylation of PLC-gamma1](#)

Followed by: [Translocation of PLC-gamma1 to PIP2](#)

Translocation of PLC-gamma1 to PIP2 ↗

Location: [Generation of second messenger molecules](#)

Stable identifier: R-MMU-202354

Type: binding

Compartments: cytosol, plasma membrane

Inferred from: [Translocation of PLC-gamma1 to PIP2 \(Homo sapiens\)](#)

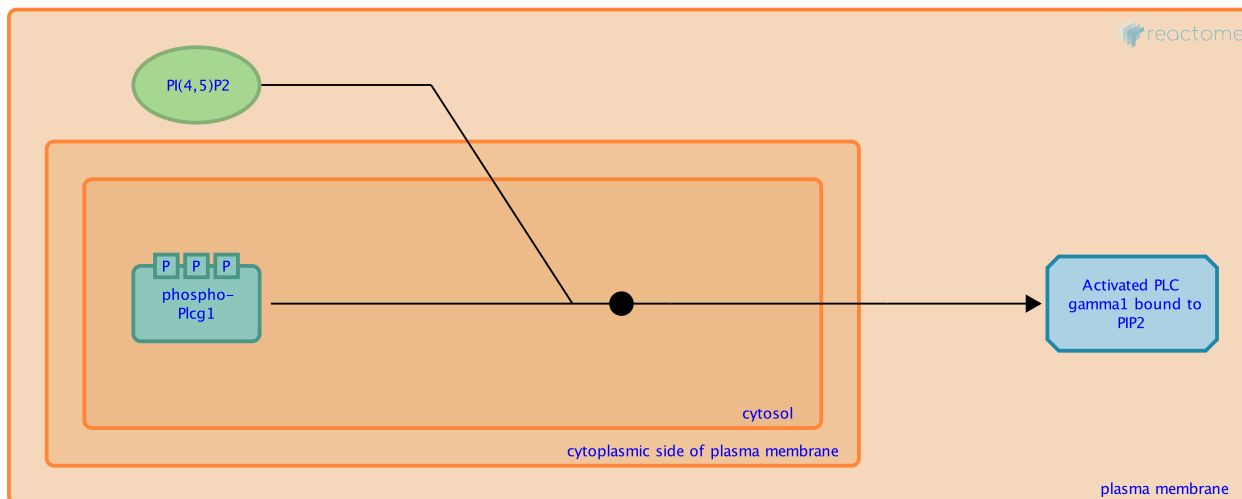

This event has been computationally inferred from an event that has been demonstrated in another species.

The inference is based on the homology mapping from PANTHER. Briefly, reactions for which all involved PhysicalEntities (in input, output and catalyst) have a mapped orthologue/paralogue (for complexes at least 75% of components must have a mapping) are inferred to the other species. High level events are also inferred for these events to allow for easier navigation.

[More details and caveats of the event inference in Reactome.](/electronic_inference_compara.html) For details on PANTHER see also: <http://www.pantherdb.org/about.jsp>

Preceded by: [Disassociation of PLC-gamma1 from LAT](#), [Disassociation of PLC-gamma1 from SLP-76](#), [Phosphorylation of PLC-gamma1](#)

Followed by: [PLC-gamma1 hydrolyses PIP2](#)

PLC-gamma1 hydrolyses PIP2 ↗

Location: [Generation of second messenger molecules](#)

Stable identifier: R-MMU-202407

Type: transition

Compartments: cytosol, plasma membrane

Inferred from: [PLC-gamma1 hydrolyses PIP2 \(Homo sapiens\)](#)

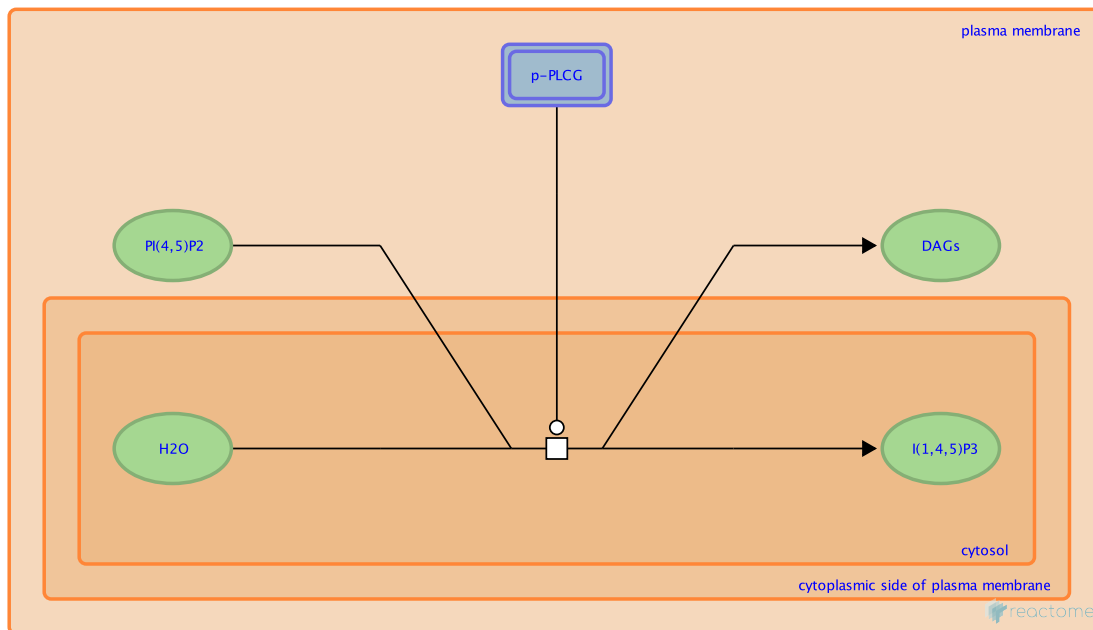

This event has been computationally inferred from an event that has been demonstrated in another species.

The inference is based on the homology mapping from PANTHER. Briefly, reactions for which all involved PhysicalEntities (in input, output and catalyst) have a mapped orthologue/paralogue (for complexes at least 75% of components must have a mapping) are inferred to the other species. High level events are also inferred for these events to allow for easier navigation.

[More details and caveats of the event inference in Reactome.](/electronic_inference_compara.html) For details on PANTHER see also: <http://www.pantherdb.org/about.jsp>

Preceded by: [Translocation of PLC-gamma1 to PIP2](#)

p-SLP-76 binds ADAP [↗](#)

Location: [Generation of second messenger molecules](#)

Stable identifier: R-MMU-430135

Type: binding

Compartments: cytosol

Inferred from: [p-SLP-76 binds ADAP \(Homo sapiens\)](#)

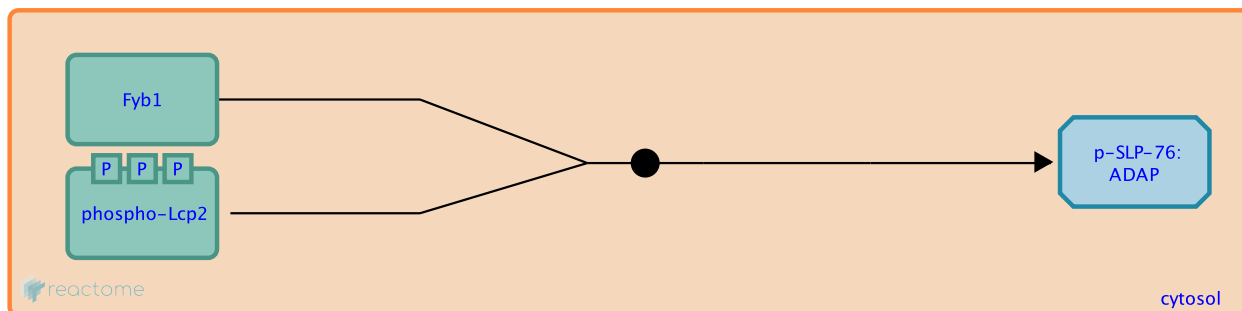

This event has been computationally inferred from an event that has been demonstrated in another species.

The inference is based on the homology mapping from PANTHER. Briefly, reactions for which all involved PhysicalEntities (in input, output and catalyst) have a mapped orthologue/paralogue (for complexes at least 75% of components must have a mapping) are inferred to the other species. High level events are also inferred for these events to allow for easier navigation.

[More details and caveats of the event inference in Reactome.](/electronic_inference_compara.html) For details on PANTHER see also: <http://www.pantherdb.org/about.jsp>

Preceded by: [Phosphorylation of SLP-76](#)

p-SLP-76 binds NCK ↗

Location: [Generation of second messenger molecules](#)

Stable identifier: R-MMU-430190

Type: binding

Compartments: cytosol

Inferred from: [p-SLP-76 binds NCK \(Homo sapiens\)](#)

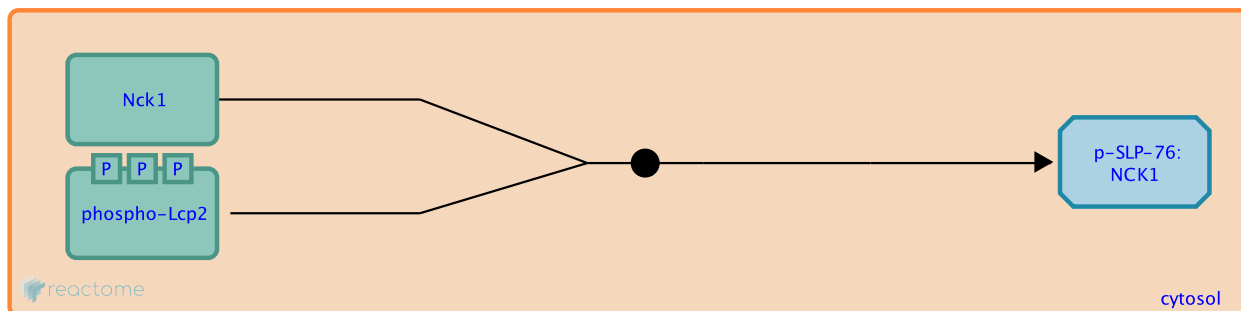

This event has been computationally inferred from an event that has been demonstrated in another species.

The inference is based on the homology mapping from PANTHER. Briefly, reactions for which all involved PhysicalEntities (in input, output and catalyst) have a mapped orthologue/paralogue (for complexes at least 75% of components must have a mapping) are inferred to the other species. High level events are also inferred for these events to allow for easier navigation.

[More details and caveats of the event inference in Reactome.](/electronic_inference_compara.html) For details on PANTHER see also: <http://www.pantherdb.org/about.jsp>

NCK binds PAK ↗

Location: [Generation of second messenger molecules](#)

Stable identifier: R-MMU-430183

Type: binding

Compartments: cytosol

Inferred from: [NCK binds PAK \(Homo sapiens\)](#)

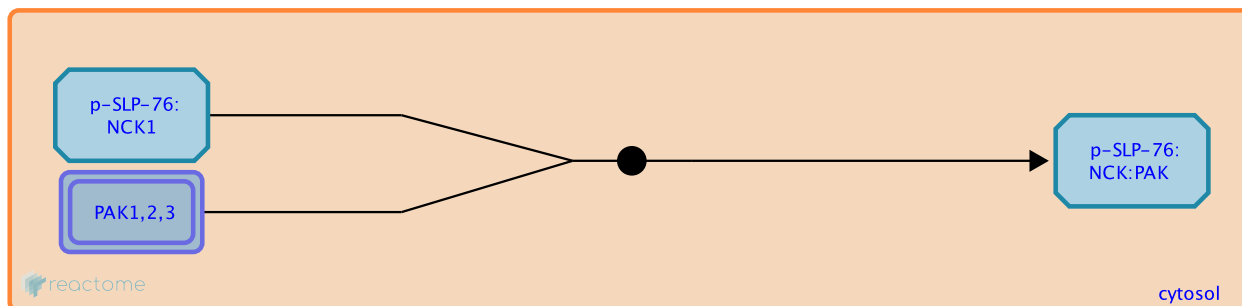

This event has been computationally inferred from an event that has been demonstrated in another species.

The inference is based on the homology mapping from PANTHER. Briefly, reactions for which all involved PhysicalEntities (in input, output and catalyst) have a mapped orthologue/paralogue (for complexes at least 75% of components must have a mapping) are inferred to the other species. High level events are also inferred for these events to allow for easier navigation.

[More details and caveats of the event inference in Reactome.](/electronic_inference_compara.html) For details on PANTHER see also: <http://www.pantherdb.org/about.jsp>

NCK recruits WASP ↗

Location: [Generation of second messenger molecules](#)

Stable identifier: R-MMU-430180

Type: binding

Compartments: cytosol

Inferred from: [NCK recruits WASP \(Homo sapiens\)](#)

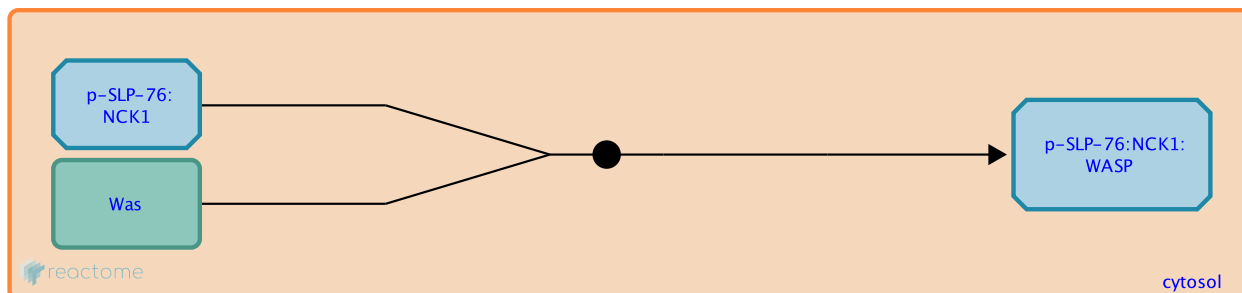

This event has been computationally inferred from an event that has been demonstrated in another species.

The inference is based on the homology mapping from PANTHER. Briefly, reactions for which all involved PhysicalEntities (in input, output and catalyst) have a mapped orthologue/paralogue (for complexes at least 75% of components must have a mapping) are inferred to the other species. High level events are also inferred for these events to allow for easier navigation.

[More details and caveats of the event inference in Reactome.](/electronic_inference_compara.html) For details on PANTHER see also: <http://www.pantherdb.org/about.jsp>

Table of Contents

Introduction	1
Generation of second messenger molecules	2
↳ Phosphorylation of TBSMs in LAT	3
↳ Recruitment of Gads to LAT	4
↳ Recruitment of SLP-76 to Gads	5
↳ Phosphorylation of SLP-76	6
↳ Recruitment of ITK to SLP-76	7
↳ Recruitment of PLC-gamma1 to SLP-76	8
↳ Recruitment of PLC-gamma1 to LAT	9
↳ Phosphorylation of PLC-gamma1	10
↳ Disassociation of PLC-gamma1 from LAT	11
↳ Disassociation of PLC-gamma1 from SLP-76	12
↳ Translocation of PLC-gamma1 to PIP2	13
↳ PLC-gamma1 hydrolyses PIP2	14
↳ p-SLP-76 binds ADAP	15
↳ p-SLP-76 binds NCK	16
↳ NCK binds PAK	17
↳ NCK recruits WASP	18
Table of Contents	19