

Endosomal Sorting Complex Required For Transport (ESCRT)

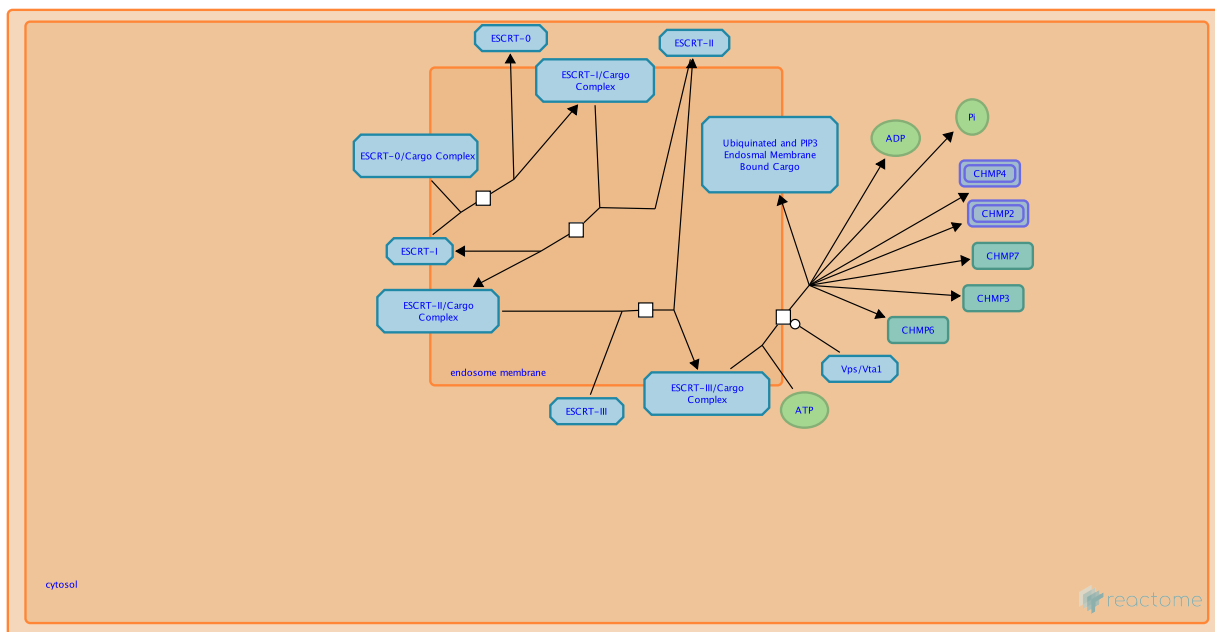

Gillespie, ME., Rush, MG.

European Bioinformatics Institute, New York University Langone Medical Center, Ontario Institute for Cancer Research, Oregon Health and Science University.

The contents of this document may be freely copied and distributed in any media, provided the authors, plus the institutions, are credited, as stated under the terms of [Creative Commons Attribution 4.0 International \(CC BY 4.0\) License](https://creativecommons.org/licenses/by/4.0/). For more information see our [license](https://creativecommons.org/licenses/by/4.0/).

Introduction

Reactome is open-source, open access, manually curated and peer-reviewed pathway database. Pathway annotations are authored by expert biologists, in collaboration with Reactome editorial staff and cross-referenced to many bioinformatics databases. A system of evidence tracking ensures that all assertions are backed up by the primary literature. Reactome is used by clinicians, geneticists, genomics researchers, and molecular biologists to interpret the results of high-throughput experimental studies, by bioinformaticians seeking to develop novel algorithms for mining knowledge from genomic studies, and by systems biologists building predictive models of normal and disease variant pathways.

The development of Reactome is supported by grants from the US National Institutes of Health (P41 HG003751), University of Toronto (CFREF Medicine by Design), European Union (EU STRP, EMI-CD), and the European Molecular Biology Laboratory (EBI Industry program).

Literature references

- Fabregat, A., Sidiropoulos, K., Viteri, G., Forner, O., Marin-Garcia, P., Arnau, V. et al. (2017). Reactome pathway analysis: a high-performance in-memory approach. *BMC bioinformatics*, 18, 142. [↗](#)
- Sidiropoulos, K., Viteri, G., Sevilla, C., Jupe, S., Webber, M., Orlic-Milacic, M. et al. (2017). Reactome enhanced pathway visualization. *Bioinformatics*, 33, 3461-3467. [↗](#)
- Fabregat, A., Jupe, S., Matthews, L., Sidiropoulos, K., Gillespie, M., Garapati, P. et al. (2018). The Reactome Pathway Knowledgebase. *Nucleic Acids Res*, 46, D649-D655. [↗](#)
- Fabregat, A., Korninger, F., Viteri, G., Sidiropoulos, K., Marin-Garcia, P., Ping, P. et al. (2018). Reactome graph database: Efficient access to complex pathway data. *PLoS computational biology*, 14, e1005968. [↗](#)

Reactome database release: 77

This document contains 1 pathway and 4 reactions ([see Table of Contents](#))

Endosomal Sorting Complex Required For Transport (ESCRT) ↗

Stable identifier: R-HSA-917729

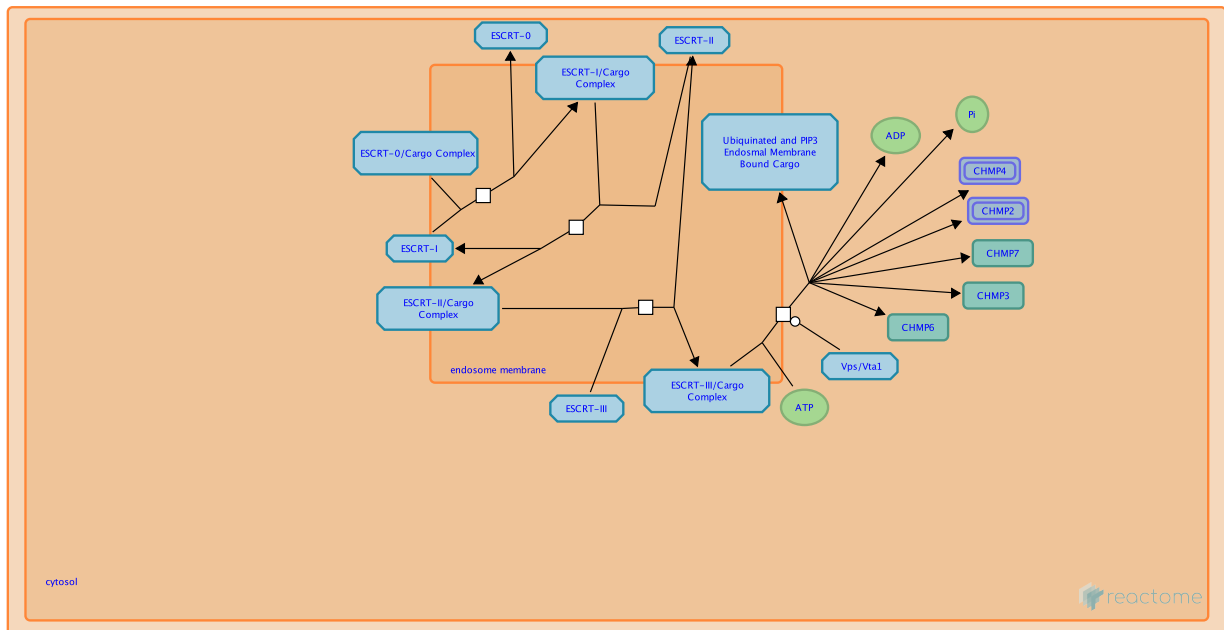

Many plasma membrane proteins are in a constant flux throughout the internal trafficking pathways of the cell. Some receptors are continuously internalized into recycling endosomes and returned to the cell surface. Others are sorted into intraluminal vesicles of morphologically distinctive endosomes that are known as multivesicular bodies (MVBs). These MVBs fuse with lysosomes, resulting in degradation of their cargo by lysosomal acidic hydrolases.

Endosomes can be operationally defined as being either early or late, referring to the relative time it takes for endocytosed material to reach either stage. Ultrastructural studies indicate that early endosomes are predominantly tubulovesicular structures, which constitute a major sorting platform in the cell, whereas late endosomes show the characteristics of typical MVBs and are capable of fusing with lysosomes.

A well characterized signal for shunting membrane proteins into the degradative MVB pathway is the ubiquitylation of these cargoes. At the center of a vast protein:protein and protein:lipid interaction network that underpins ubiquitin mediated sorting to the lysosome are the endosomal sorting complexes required for transport (ESCRTs), which are conserved throughout all major eukaryotic taxa.

Literature references

Teis, D., Saksena, S., Emr, SD. (2009). SnapShot: the ESCRT machinery. *Cell*, 137, 182-182.e1. ↗

Saksena, S., Sun, J., Chu, T., Emr, SD. (2007). ESCRTing proteins in the endocytic pathway. *Trends Biochem Sci*, 32, 561-73. ↗

Williams, RL., Urbé, S. (2007). The emerging shape of the ESCRT machinery. *Nat Rev Mol Cell Biol*, 8, 355-68. ↗

Editions

2008-01-11	Reviewed	Rush, MG.
2010-08-10	Authored, Edited	Gillespie, ME.

Cargo Recognition And Sorting ↗

Location: [Endosomal Sorting Complex Required For Transport \(ESCRT\)](#)

Stable identifier: R-HSA-917730

Type: transition

Compartments: plasma membrane

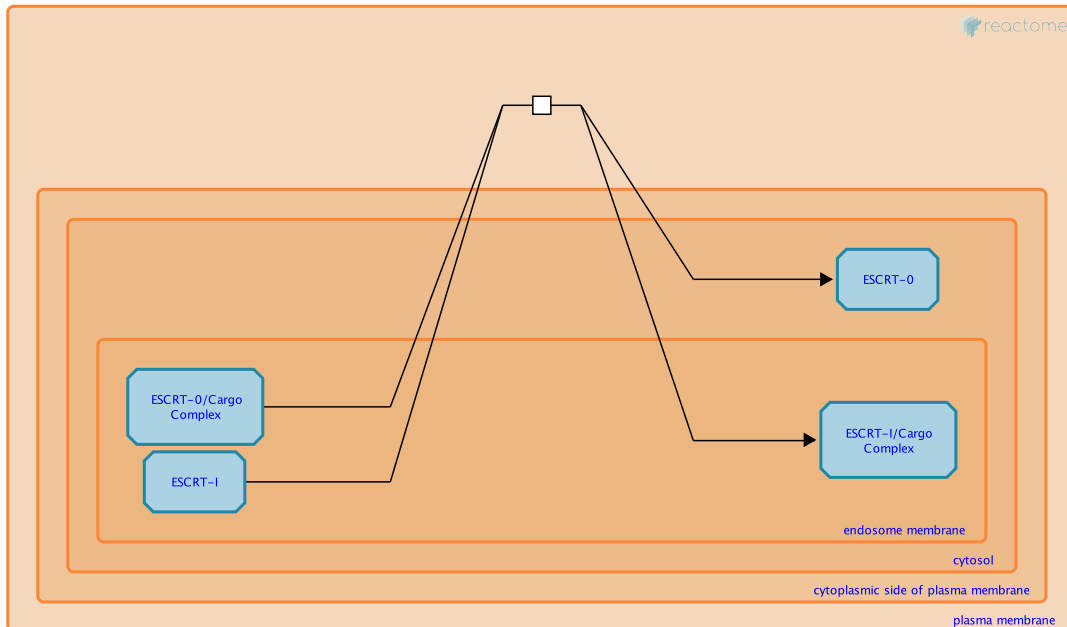

Initiation/Cargo Recognition is mediated by ESCRT-0, a heterodimer consisting of Vps27 and Hse1. ESCRT-0 binds Phosphatidyl inositol 3- phosphate (PI3P) on endosomes via a FVYE domain and ubiquitinated cargo via two UIM domains.

Followed by: [Cargo Sequestration](#)

Literature references

Stuchell, MD., Garrus, JE., Muller, B., Stray, KM., Ghaffarian, S., McKinnon, R. et al. (2004). The human endosomal sorting complex required for transport (ESCRT-I) and its role in HIV-1 budding. *J Biol Chem*, 279, 36059-71. ↗

Clague, MJ., Urbé, S. (2003). Hrs function: viruses provide the clue. *Trends Cell Biol*, 13, 603-6. ↗

Editions

2008-01-11	Reviewed	Rush, MG.
2010-08-10	Authored, Edited	Gillespie, ME.

Cargo Sequestration ↗

Location: [Endosomal Sorting Complex Required For Transport \(ESCRT\)](#)

Stable identifier: R-HSA-917696

Type: transition

Compartments: cytosol, endosome membrane

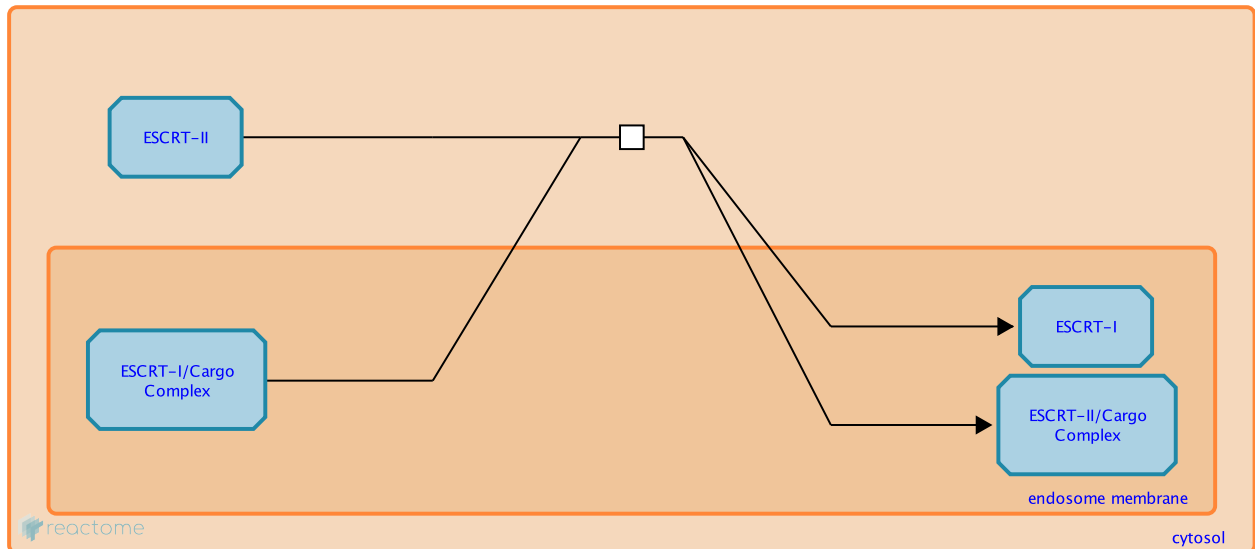

ESCRT-0 recruits ESCRT-I and thereby initiates the MVB pathway. Cargo Sorting ESCRT-I is a heterotetramer consisting of Vps23, Vps28, Vps37 (VPS37A, VPS37B, VPS37C or VPS37D), and Mvb12/Ubap1 (MVB12A, MVB12B or UBAP1). The UEV domain of Vps23 binds ubiquitinated membrane proteins. Vps28 interacts with the GLUE domain of Vps36 in ESCRT-II. Cargo Sorting ESCRT-II is a heterotetramer formed of Vps36, Vps22, and two Vps25 molecules. The GLUE domain of Vps36 binds PI3P, Vps28, and ubiquitinated membrane proteins. Vps25 interacts with Vps20 of ESCRT-III.

Preceded by: [Cargo Recognition And Sorting](#)

Followed by: [MVB Vesicle Formation](#)

Literature references

Stuchell, MD., Garrus, JE., Muller, B., Stray, KM., Ghaffarian, S., McKinnon, R. et al. (2004). The human endosomal sorting complex required for transport (ESCRT-I) and its role in HIV-1 budding. *J Biol Chem*, 279, 36059-71. ↗

Stefani, F., Zhang, L., Taylor, S., Donovan, J., Rollinson, S., Doyotte, A. et al. (2011). UBAP1 is a component of an endosome-specific ESCRT-I complex that is essential for MVB sorting. *Curr. Biol.*, 21, 1245-50. ↗

Editions

2008-01-11	Reviewed	Rush, MG.
2010-08-10	Authored, Edited	Gillespie, ME.

MVB Vesicle Formation ↗

Location: Endosomal Sorting Complex Required For Transport (ESCRT)

Stable identifier: R-HSA-917700

Type: transition

Compartments: cytosol, endosome membrane

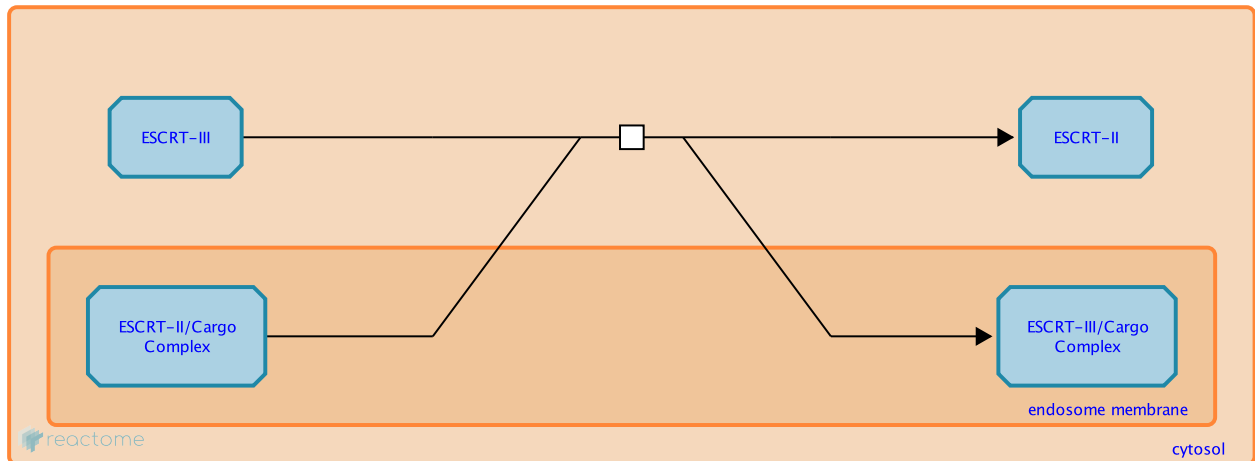

ESCRT-III assembles into a highly ordered filament-like hetero-oligomer. Vps20 nucleates the homo-oligomerization of Snf7 that is capped by Vps24. Vps24 recruits Vps2 and initiates Vps4-dependent ESCRT-III disassembly. ESCRT-III is required for the last steps of MVB sorting, cargo sequestration, and MVB vesicle formation.

Preceded by: [Cargo Sequestration](#)

Followed by: [ESCRT Disassembly](#)

Literature references

Langelier, C., von Schwedler, UK., Fisher, RD., De Domenico, I., White, PL., Hill, CP. et al. (2006). Human ESCRT-II complex and its role in human immunodeficiency virus type 1 release. *J Virol*, 80, 9465-80. ↗

Bowers, K., Piper, SC., Edeling, MA., Gray, SR., Owen, DJ., Lehner, PJ. et al. (2006). Degradation of endocytosed epidermal growth factor and virally ubiquitinated major histocompatibility complex class I is independent of mammalian ESCRTII. *J Biol Chem*, 281, 5094-105. ↗

Editions

2008-01-11	Reviewed	Rush, MG.
2010-08-10	Authored, Edited	Gillespie, ME.

ESCRT Disassembly ↗

Location: [Endosomal Sorting Complex Required For Transport \(ESCRT\)](#)

Stable identifier: R-HSA-917693

Type: transition

Compartments: endosome membrane

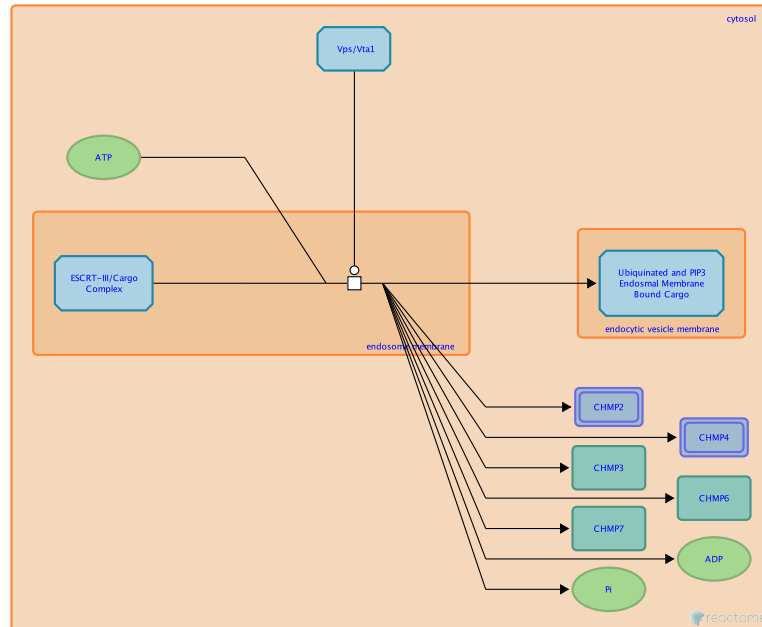

Disassembly Phase

The AAA-ATPase, Vps4 disassembles ESCRT-III and catalyzes the final step of the MVB pathway. The microtubule interacting and trafficking (MIT) domain of Vps4 interacts directly with the C-terminal region of Vps2 (MIM1) and Vps20 (MIM2). The association of Vta1, which contains two MIT domains, greatly enhances the activity of Vps4. Please note that the recommended names of the Vacuolar protein sorting-associated proteins (Vps) are Charged multivesicular body proteins or CHMPs.

Preceded by: [MVB Vesicle Formation](#)

Literature references

Sachse, M., Strous, GJ., Klumperman, J. (2004). ATPase-deficient hVPS4 impairs formation of internal endosomal vesicles and stabilizes bilayered clathrin coats on endosomal vacuoles. *J Cell Sci*, 117, 1699-708. ↗

Scheuring, S., Röhrich, RA., Schöning-Burkhardt, B., Beyer, A., Müller, S., Abts, HF. et al. (2001). Mammalian cells express two VPS4 proteins both of which are involved in intracellular protein trafficking. *J Mol Biol*, 312, 469-80. ↗

Editions

2008-01-11	Reviewed	Rush, MG.
2010-08-10	Authored, Edited	Gillespie, ME.

Table of Contents

Introduction	1
❏ Endosomal Sorting Complex Required For Transport (ESCRT)	2
➤ Cargo Recognition And Sorting	3
➤ Cargo Sequestration	4
➤ MVB Vesicle Formation	5
➤ ESCRT Disassembly	6
Table of Contents	7