

Synthesis of active ubiquitin: roles of E1 and E2 enzymes

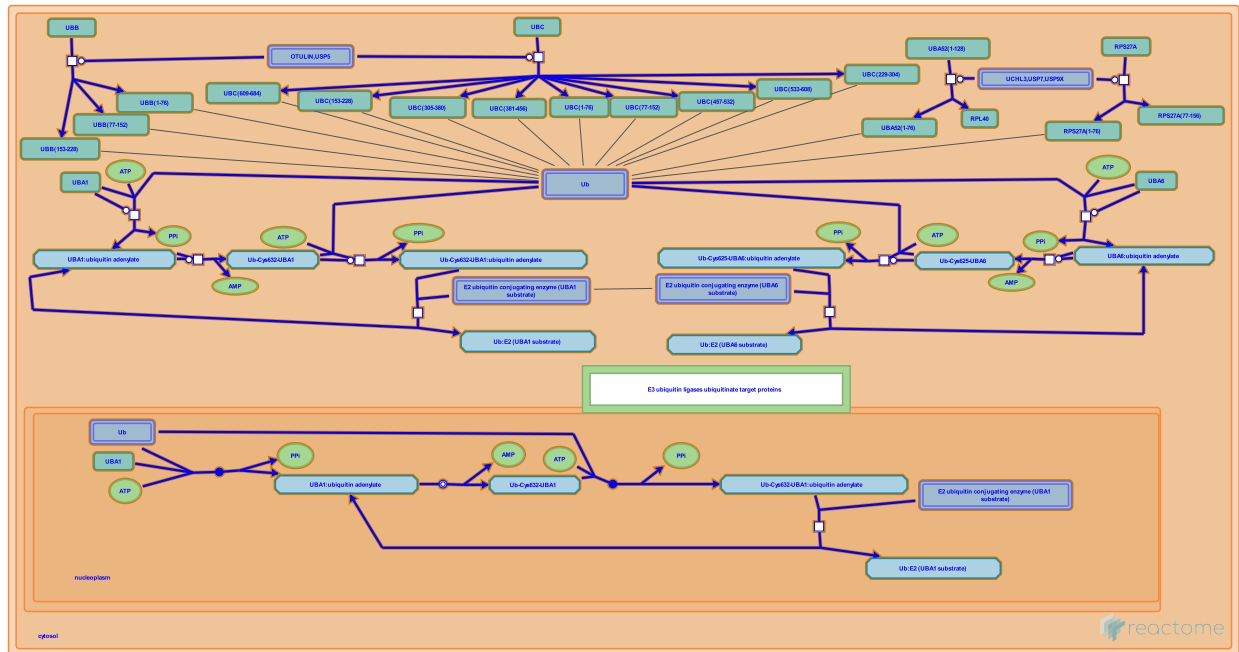

Azevedo, JE., May, B.

European Bioinformatics Institute, New York University Langone Medical Center, Ontario Institute for Cancer Research, Oregon Health and Science University.

The contents of this document may be freely copied and distributed in any media, provided the authors, plus the institutions, are credited, as stated under the terms of [Creative Commons Attribution 4.0 International \(CC BY 4.0\) License](https://creativecommons.org/licenses/by/4.0/). For more information see our [license](https://reactome.org/about/faq).

This is just an excerpt of a full-length report for this pathway. To access the complete report, please download it at the [Reactome Textbook](https://reactome.org/textbook).

27/04/2024

Introduction

Reactome is open-source, open access, manually curated and peer-reviewed pathway database. Pathway annotations are authored by expert biologists, in collaboration with Reactome editorial staff and cross-referenced to many bioinformatics databases. A system of evidence tracking ensures that all assertions are backed up by the primary literature. Reactome is used by clinicians, geneticists, genomics researchers, and molecular biologists to interpret the results of high-throughput experimental studies, by bioinformaticians seeking to develop novel algorithms for mining knowledge from genomic studies, and by systems biologists building predictive models of normal and disease variant pathways.

The development of Reactome is supported by grants from the US National Institutes of Health (P41 HG003751), University of Toronto (CFREF Medicine by Design), European Union (EU STRP, EMI-CD), and the European Molecular Biology Laboratory (EBI Industry program).

Literature references

- Fabregat, A., Sidiropoulos, K., Viteri, G., Forner, O., Marin-Garcia, P., Arnau, V. et al. (2017). Reactome pathway analysis: a high-performance in-memory approach. *BMC bioinformatics*, 18, 142. [↗](#)
- Sidiropoulos, K., Viteri, G., Sevilla, C., Jupe, S., Webber, M., Orlic-Milacic, M. et al. (2017). Reactome enhanced pathway visualization. *Bioinformatics*, 33, 3461-3467. [↗](#)
- Fabregat, A., Jupe, S., Matthews, L., Sidiropoulos, K., Gillespie, M., Garapati, P. et al. (2018). The Reactome Pathway Knowledgebase. *Nucleic Acids Res*, 46, D649-D655. [↗](#)
- Fabregat, A., Korninger, F., Viteri, G., Sidiropoulos, K., Marin-Garcia, P., Ping, P. et al. (2018). Reactome graph database: Efficient access to complex pathway data. *PLoS computational biology*, 14, e1005968. [↗](#)

Reactome database release: 88

This document contains 1 pathway and 16 reactions ([see Table of Contents](#))

Synthesis of active ubiquitin: roles of E1 and E2 enzymes ↗

Stable identifier: R-HSA-8866652

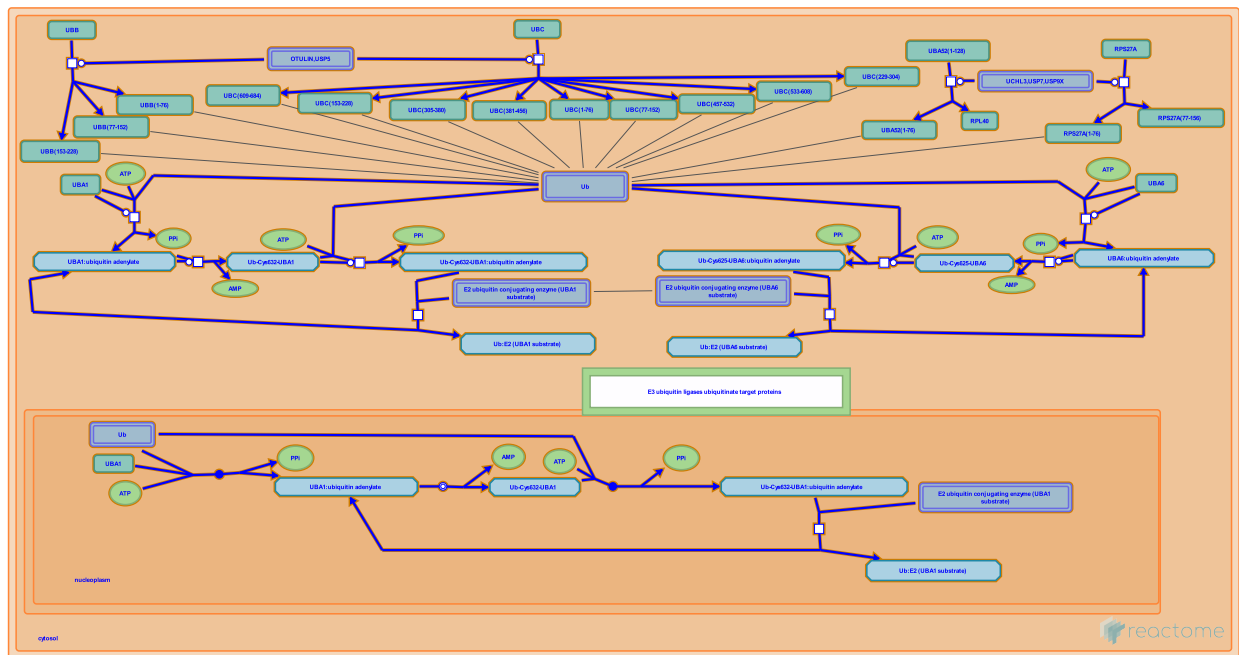

Ubiquitin monomers are processed from larger precursors and then activated by formation of a thiol ester bond between ubiquitin and a cysteine residue of an E1 activating enzyme (UBA1 or UBA6, Jin et al. 2007). The ubiquitin is then transferred to the active site cysteine residue of an E2 conjugating enzyme (reviewed in van Wijk and Timmers 2010, Kleiger and Mayor 2014, Stewart et al. 2016). Precursor proteins containing multiple ubiquitin monomers (polyubiquitins) are produced from the UBB and UBC genes. Precursors containing a single ubiquitin fused to a ribosomal protein are produced from the UBA52 and RPS27A genes. The proteases OTULIN and USP5 are very active in polyubiquitin processing, whereas the proteases UCHL3, USP7, and USP9X cleave the ubiquitin-ribosomal protein precursors yielding ubiquitin monomers (Grou et al. 2015). Other enzymes may also process ubiquitin precursors. A resultant ubiquitin monomer is activated by adenylation of its C-terminal glycine followed by conjugation of the C-terminus to a cysteine residue of the E1 enzymes UBA1 or UBA6 via a thiol ester bond (Jin et al. 2007, inferred from rabbit homologues in Haas et al. 1982, Hershko et al. 1983). The ubiquitin is then transferred from the E1 enzyme to a cysteine residue of one of several E2 enzymes (reviewed in van Wijk and Timmers 2010, Stewart et al. 2016).

Literature references

- Domingues, P., Grou, CP., Azevedo, JE., Pinto, MP., Mendes, AV. (2015). The de novo synthesis of ubiquitin: identification of deubiquitinases acting on ubiquitin precursors. *Sci Rep*, 5, 12836. ↗
- Klevit, RE., Ritterhoff, T., Brzovic, PS., Stewart, MD. (2016). E2 enzymes: more than just middle men. *Cell Res.*, 26, 423-40. ↗
- Li, X., Gygi, SP., Jin, J., Harper, JW. (2007). Dual E1 activation systems for ubiquitin differentially regulate E2 enzyme charging. *Nature*, 447, 1135-8. ↗
- Rose, IA., Hershko, A., Haas, AL., Warmus, JV. (1982). Ubiquitin-activating enzyme. Mechanism and role in protein-ubiquitin conjugation. *J. Biol. Chem.*, 257, 2543-8. ↗
- Timmers, HT., van Wijk, SJ. (2010). The family of ubiquitin-conjugating enzymes (E2s): deciding between life and death of proteins. *FASEB J*, 24, 981-93. ↗

Editions

2016-04-02	Authored, Edited	May, B.
2016-08-11	Reviewed	Azevedo, JE.

OTULIN, USP5 cleaves UBB yielding ubiquitin ↗

Location: [Synthesis of active ubiquitin: roles of E1 and E2 enzymes](#)

Stable identifier: R-HSA-8853529

Type: transition

Compartments: cytosol

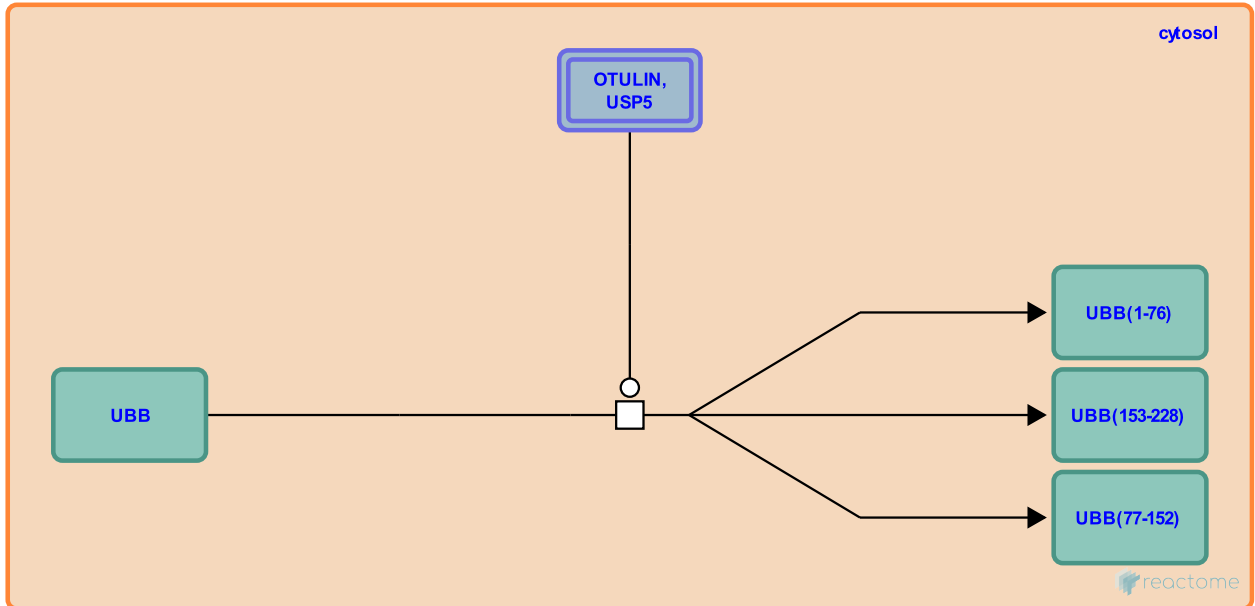

The UBB poly-protein contains 3 Ubiquitin monomers that are released by proteolysis. Either USP5 (Falquet et al. 1995) or OTULIN can perform the proteolytic cleavage reactions (Grou et al. 2015).

Followed by: [UBA6 adenylates ubiquitin in the cytosol](#), [UBA1 adenylates ubiquitin in the cytosol](#)

Literature references

Domingues, P., Grou, CP., Azevedo, JE., Pinto, MP., Mendes, AV. (2015). The de novo synthesis of ubiquitin: identification of deubiquitinases acting on ubiquitin precursors. *Sci Rep*, 5, 12836. ↗

Falquet, L., Jatton, JC., Hoang-Van, K., Paquet, N., Hughes, GJ., Frutiger, S. (1995). A human de-ubiquitinating enzyme with both isopeptidase and peptidase activities in vitro. *FEBS Lett.*, 359, 73-7. ↗

Editions

2016-01-15	Authored, Edited	May, B.
2016-08-11	Reviewed	Azevedo, JE.

OTULIN, USP5 cleaves UBC yielding ubiquitin ↗

Location: [Synthesis of active ubiquitin: roles of E1 and E2 enzymes](#)

Stable identifier: R-HSA-8853515

Type: transition

Compartments: cytosol

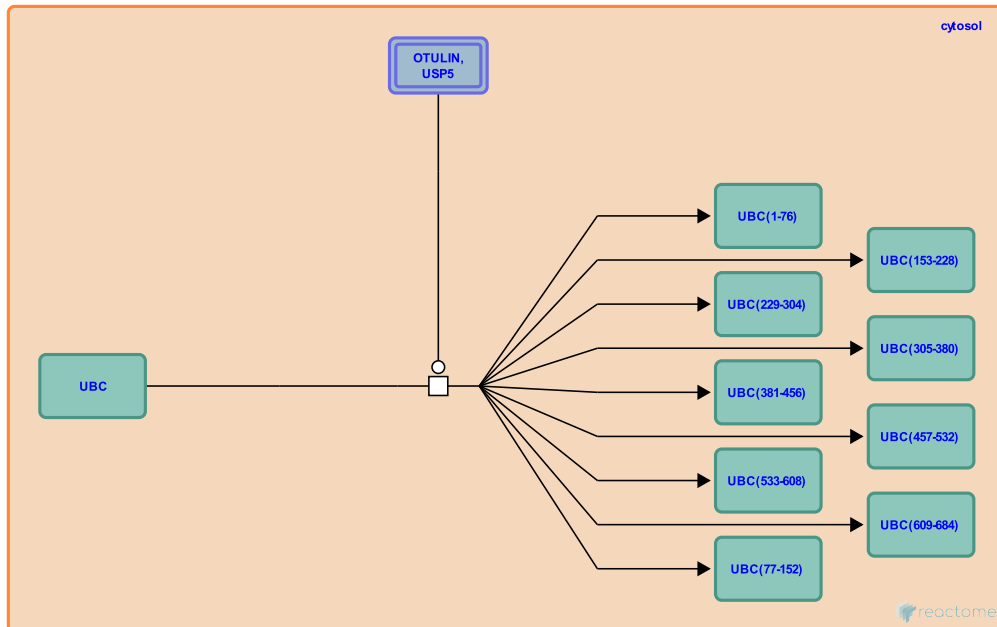

The UBC poly-protein contains 9 Ubiquitin monomers that are released by proteolysis. Either USP5 (Falquet et al. 1995) or OTULIN can perform the proteolytic cleavage reactions (Grou et al. 2015).

Followed by: [UBA6 adenylates ubiquitin in the cytosol](#), [UBA1 adenylates ubiquitin in the cytosol](#)

Literature references

Domingues, P., Grou, CP., Azevedo, JE., Pinto, MP., Mendes, AV. (2015). The de novo synthesis of ubiquitin: identification of deubiquitinases acting on ubiquitin precursors. *Sci Rep*, 5, 12836. ↗

Falquet, L., Jaton, JC., Hoang-Van, K., Paquet, N., Hughes, GJ., Frutiger, S. (1995). A human de-ubiquitinating enzyme with both isopeptidase and peptidase activities in vitro. *FEBS Lett.*, 359, 73-7. ↗

Editions

2016-01-15	Authored, Edited	May, B.
2016-08-11	Reviewed	Azevedo, JE.

UCHL3,USP7,USP9X cleaves UBA52 yielding ubiquitin ↗

Location: [Synthesis of active ubiquitin: roles of E1 and E2 enzymes](#)

Stable identifier: R-HSA-8853514

Type: transition

Compartments: cytosol

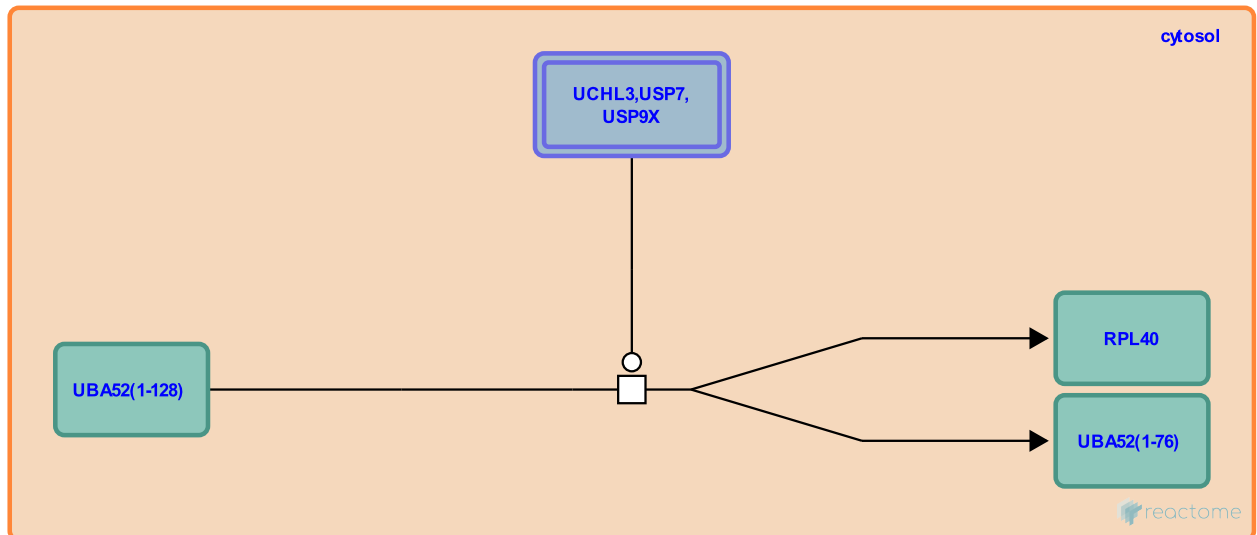

The UBA52 precursor protein contains the ribosomal protein L40 and ubiquitin (UBA52 residues 1 to 76) which are released by proteolysis. Any of the proteases UCHL3, USP7, or USP9X can catalyze the proteolysis reaction (Larsen et al. 1998, Grou et al. 2015).

Followed by: [UBA6 adenylates ubiquitin in the cytosol](#), [UBA1 adenylates ubiquitin in the cytosol](#)

Literature references

Wilkinson, KD., Larsen, CN., Krantz, BA. (1998). Substrate specificity of deubiquitinating enzymes: ubiquitin C-terminal hydrolases. *Biochemistry*, 37, 3358-68. ↗

Domingues, P., Grou, CP., Azevedo, JE., Pinto, MP., Mendes, AV. (2015). The de novo synthesis of ubiquitin: identification of deubiquitinases acting on ubiquitin precursors. *Sci Rep*, 5, 12836. ↗

Editions

2016-01-15	Authored, Edited	May, B.
2016-08-11	Reviewed	Azevedo, JE.

UCHL3,USP7,USP9X cleaves RPS27A yielding ubiquitin ↗

Location: [Synthesis of active ubiquitin: roles of E1 and E2 enzymes](#)

Stable identifier: R-HSA-8853503

Type: transition

Compartments: cytosol

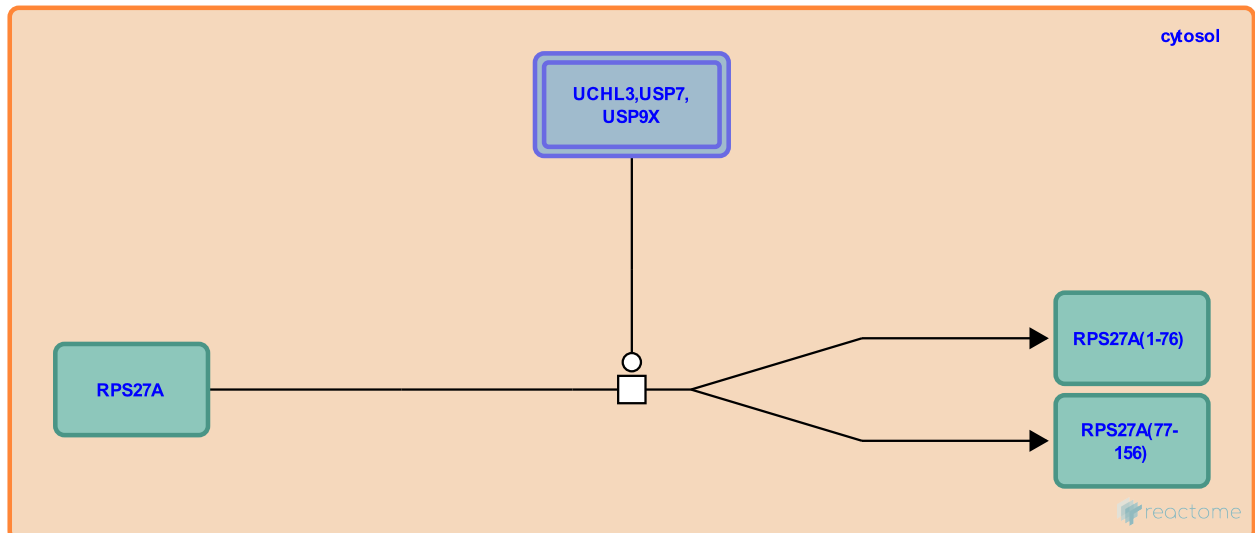

The RPS27A precursor protein contains the ribosomal protein L40 and ubiquitin (RPS27A residues 1 to 76) which are released by proteolysis. Any of the proteases UCHL3, USP7, or USP9X can catalyze the proteolysis reaction (Larsen et al. 1998, Grou et al. 2015).

Followed by: [UBA6 adenylates ubiquitin in the cytosol](#), [UBA1 adenylates ubiquitin in the cytosol](#)

Literature references

Wilkinson, KD., Larsen, CN., Krantz, BA. (1998). Substrate specificity of deubiquitinating enzymes: ubiquitin C-terminal hydrolases. *Biochemistry*, 37, 3358-68. ↗

Domingues, P., Grou, CP., Azevedo, JE., Pinto, MP., Mendes, AV. (2015). The de novo synthesis of ubiquitin: identification of deubiquitinases acting on ubiquitin precursors. *Sci Rep*, 5, 12836. ↗

Editions

2016-01-15	Authored, Edited	May, B.
2016-08-11	Reviewed	Azevedo, JE.

UBA1 adenylates ubiquitin in the cytosol ↗

Location: [Synthesis of active ubiquitin: roles of E1 and E2 enzymes](#)

Stable identifier: R-HSA-8852134

Type: transition

Compartments: cytosol

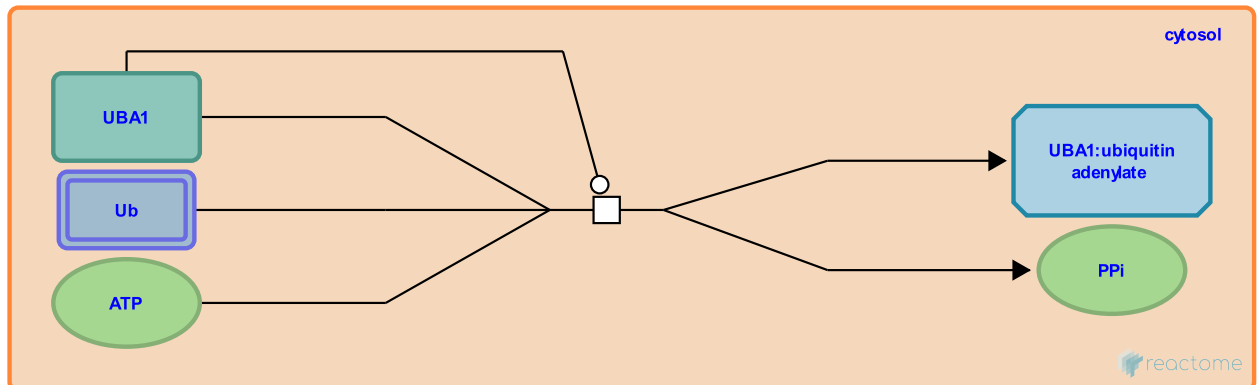

Activation of ubiquitin by UBA1 proceeds through 3 steps: adenylation of ubiquitin, conjugation of ubiquitin from adenylation-ubiquitin to an internal cysteine residue of UBA1, and adenylation of a second molecule of ubiquitin. In the first step the adenylation module of UBA1 catalyzes the acyl-adenylation of the C-terminal glycine of ubiquitin (Jin et al. 2007, inferred from the rabbit homologue in Haas et al. 1982, Hershko et al. 1983, reviewed in Groettrup et al. 2008).

Preceded by: [OTULIN, USP5 cleaves UBB yielding ubiquitin](#), [UCHL3, USP7, USP9X cleaves UBA52 yielding ubiquitin](#), [OTULIN, USP5 cleaves UBC yielding ubiquitin](#), [UCHL3, USP7, USP9X cleaves RPS27A yielding ubiquitin](#)

Followed by: [UBA1 conjugates ubiquitin to UBA1 in the cytosol](#)

Literature references

- Li, X., Gygi, SP., Jin, J., Harper, JW. (2007). Dual E1 activation systems for ubiquitin differentially regulate E2 enzyme charging. *Nature*, 447, 1135-8. ↗
- Hofmann, K., Pelzer, C., Groettrup, M., Schmidtke, G. (2008). Activating the ubiquitin family: UBA6 challenges the field. *Trends Biochem. Sci.*, 33, 230-7. ↗
- Rose, IA., Hershko, A., Haas, AL., Warms, JV. (1982). Ubiquitin-activating enzyme. Mechanism and role in protein-ubiquitin conjugation. *J. Biol. Chem.*, 257, 2543-8. ↗
- Ciechanover, A., Elias, S., Heller, H., Hershko, A. (1983). Components of ubiquitin-protein ligase system. Resolution, affinity purification, and role in protein breakdown. *J. Biol. Chem.*, 258, 8206-14. ↗

Editions

2016-01-12	Authored, Edited	May, B.
2016-08-11	Reviewed	Azevedo, JE.

UBA1 conjugates ubiquitin to UBA1 in the cytosol ↗

Location: [Synthesis of active ubiquitin: roles of E1 and E2 enzymes](#)

Stable identifier: R-HSA-8852133

Type: transition

Compartments: cytosol

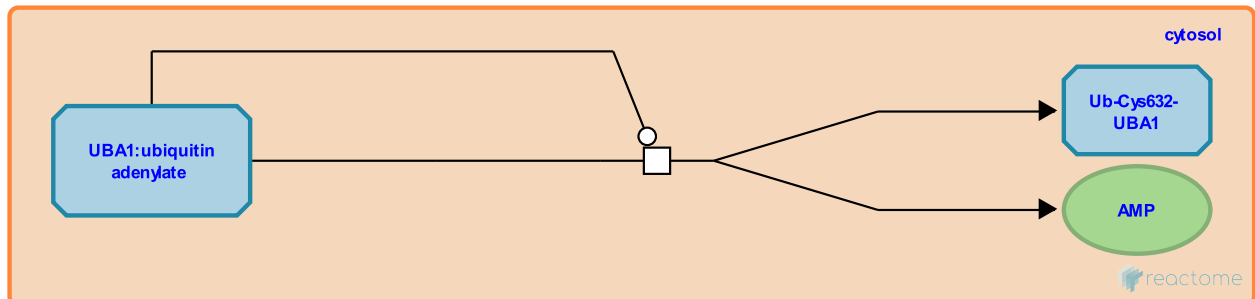

Activation of ubiquitin by UBA1 proceeds through 3 steps: adenylation of ubiquitin, conjugation of ubiquitin from adenylyl-ubiquitin to an internal cysteine residue of UBA1, and adenylation of a second molecule of ubiquitin. In the second step, the thiol group of an internal cysteine residue of UBA1 attacks the acyl-adenyl bond of the C-terminal glycine of adenylated ubiquitin, resulting in a thioester bond between the cysteine residue and the C-terminal glycine of ubiquitin (Jin et al. 2007, inferred from the rabbit homologue in Haas et al. 1982, Hershko et al. 1983, reviewed in Groettrup et al. 2008).

Preceded by: [UBA1 adenylates ubiquitin in the cytosol](#)

Followed by: [Ub-Cys632-UBA1 adenylates ubiquitin in the cytosol](#)

Literature references

- Li, X., Gygi, SP., Jin, J., Harper, JW. (2007). Dual E1 activation systems for ubiquitin differentially regulate E2 enzyme charging. *Nature*, 447, 1135-8. ↗
- Hofmann, K., Pelzer, C., Groettrup, M., Schmidtke, G. (2008). Activating the ubiquitin family: UBA6 challenges the field. *Trends Biochem. Sci.*, 33, 230-7. ↗
- Rose, IA., Hershko, A., Haas, AL., Warme, JV. (1982). Ubiquitin-activating enzyme. Mechanism and role in protein-ubiquitin conjugation. *J. Biol. Chem.*, 257, 2543-8. ↗
- Ciechanover, A., Elias, S., Heller, H., Hershko, A. (1983). Components of ubiquitin-protein ligase system. Resolution, affinity purification, and role in protein breakdown. *J. Biol. Chem.*, 258, 8206-14. ↗
- Pelzer, C., Singh, RK., Groettrup, M., Scheffner, M., Matentzoglou, K., Schmidtke, G. et al. (2007). UBE1L2, a novel E1 enzyme specific for ubiquitin. *J. Biol. Chem.*, 282, 23010-4. ↗

Editions

2016-01-12	Authored, Edited	May, B.
2016-08-11	Reviewed	Azevedo, JE.

Ub-Cys632-UBA1 adenylates ubiquitin in the cytosol ↗

Location: [Synthesis of active ubiquitin: roles of E1 and E2 enzymes](#)

Stable identifier: R-HSA-8852132

Type: transition

Compartments: cytosol

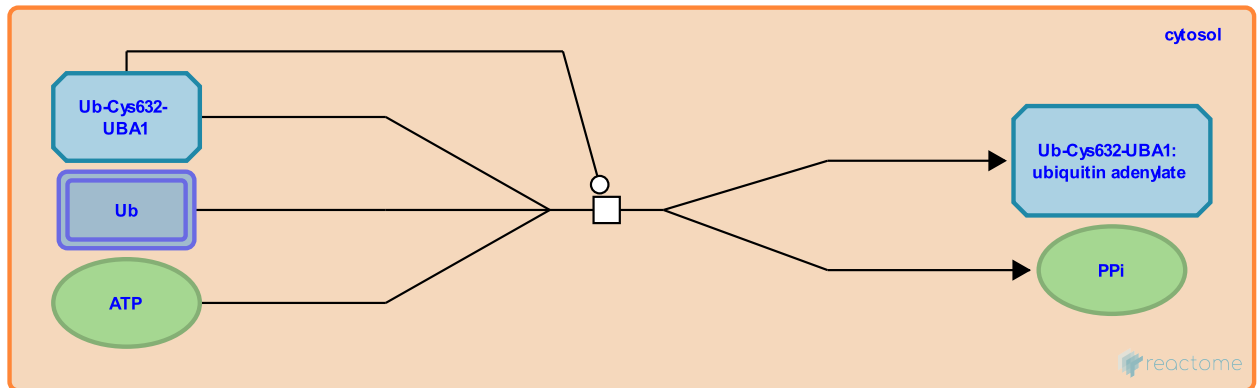

Activation of ubiquitin by UBA1 proceeds through 3 steps: adenylation of ubiquitin, conjugation of ubiquitin from adenylation-ubiquitin to an internal cysteine residue of UBA1, and adenylation of a second molecule of ubiquitin. In the third step, the UBA1-ubiquitin conjugate adenylates the C-terminal glycine of a second ubiquitin molecule. This results in UBA1 loaded with 2 ubiquitin molecules, one of which is conjugated to an internal cysteine residue of UBA1 and one of which is adenylated and non-covalently bound to UBA1 (Jin et al. 2007, inferred from the rabbit homologue in Haas et al. 1982, Hershko et al. 1983, reviewed in Groettrup et al. 2008).

Preceded by: [UBA1 conjugates ubiquitin to UBA1 in the cytosol](#)

Followed by: [UBA1 conjugates ubiquitin to cytosolic E2 enzymes](#)

Literature references

- Li, X., Gygi, SP., Jin, J., Harper, JW. (2007). Dual E1 activation systems for ubiquitin differentially regulate E2 enzyme charging. *Nature*, 447, 1135-8. ↗
- Hofmann, K., Pelzer, C., Groettrup, M., Schmidtke, G. (2008). Activating the ubiquitin family: UBA6 challenges the field. *Trends Biochem. Sci.*, 33, 230-7. ↗
- Rose, IA., Hershko, A., Haas, AL., Warms, JV. (1982). Ubiquitin-activating enzyme. Mechanism and role in protein-ubiquitin conjugation. *J. Biol. Chem.*, 257, 2543-8. ↗
- Ciechanover, A., Elias, S., Heller, H., Hershko, A. (1983). Components of ubiquitin-protein ligase system. Resolution, affinity purification, and role in protein breakdown. *J. Biol. Chem.*, 258, 8206-14. ↗

Editions

2016-01-12	Authored, Edited	May, B.
2016-08-11	Reviewed	Azevedo, JE.

UBA1 conjugates ubiquitin to cytosolic E2 enzymes [↗](#)

Location: [Synthesis of active ubiquitin: roles of E1 and E2 enzymes](#)

Stable identifier: R-HSA-8852129

Type: transition

Compartments: cytosol

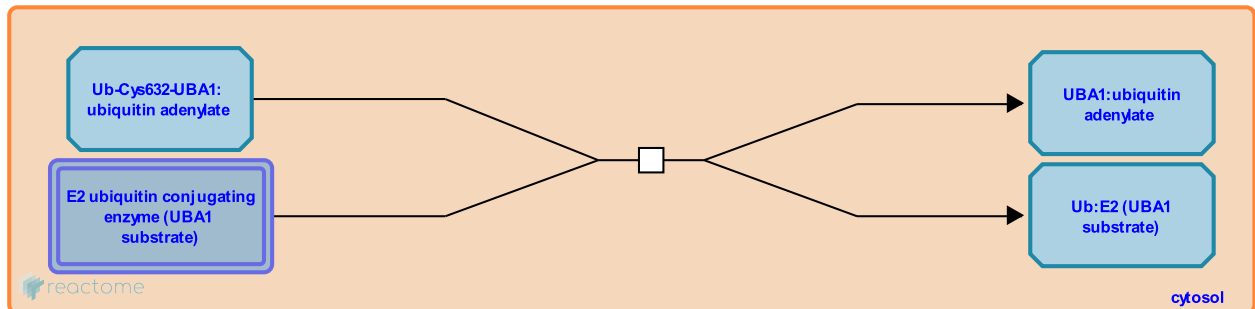

In the cytosol, the UBA1-ubiquitin thiol ester conjugate transfers ubiquitin from UBA1 to an internal cysteine residue of the E2 enzyme, forming a thiol ester conjugate between ubiquitin and the cysteine residue of E2 (Jin et al. 2007, inferred from the rabbit homologue in Hershko et al. 1983). The E2 then disengages from UBA1 (Eletr et al. 2005).

Preceded by: [Ub-Cys632-UBA1 adenylates ubiquitin in the cytosol](#)

Literature references

- Li, X., Gygi, SP., Jin, J., Harper, JW. (2007). Dual E1 activation systems for ubiquitin differentially regulate E2 enzyme charging. *Nature*, 447, 1135-8. [↗](#)
- Ciechanover, A., Elias, S., Heller, H., Hershko, A. (1983). Components of ubiquitin-protein ligase system. Resolution, affinity purification, and role in protein breakdown. *J. Biol. Chem.*, 258, 8206-14. [↗](#)
- Huang, DT., Kuhlman, B., Duda, DM., Schulman, BA., Eletr, ZM. (2005). E2 conjugating enzymes must disengage from their E1 enzymes before E3-dependent ubiquitin and ubiquitin-like transfer. *Nat. Struct. Mol. Biol.*, 12, 933-4. [↗](#)

Editions

2016-01-12	Authored, Edited	May, B.
2016-08-11	Reviewed	Azevedo, JE.

UBA6 adenylates ubiquitin in the cytosol ↗

Location: [Synthesis of active ubiquitin: roles of E1 and E2 enzymes](#)

Stable identifier: R-HSA-8865090

Type: transition

Compartments: cytosol

Inferred from: [UBA1 adenylates ubiquitin in the cytosol \(Homo sapiens\)](#)

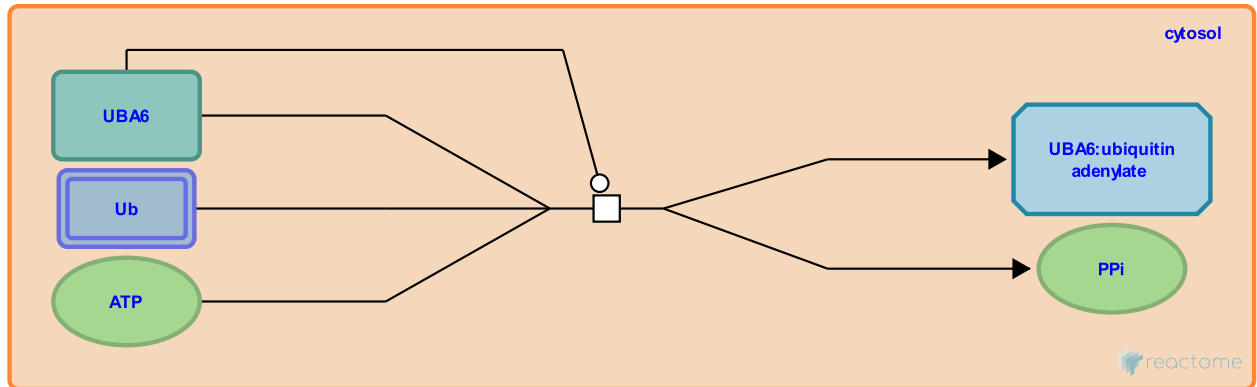

As inferred from the homologous UBA1, activation of ubiquitin by UBA6 (UBE1L1) proceeds through 3 steps: adenylation of ubiquitin, conjugation of ubiquitin from adeny-ubiquitin to an internal cysteine residue of UBA6, and adenylation of a second molecule of ubiquitin. In the first step, the adenylation module of UBA6 catalyzes the acyl-adenylation of the C-terminal glycine of ubiquitin (Jin et al. 2007, Pelzer et al. 2007, Groettrup et al. 2008).

Preceded by: [OTULIN,USP5 cleaves UBB yielding ubiquitin](#), [UCHL3,USP7,USP9X cleaves UBA52 yielding ubiquitin](#), [OTULIN,USP5 cleaves UBC yielding ubiquitin](#), [UCHL3,USP7,USP9X cleaves RPS27A yielding ubiquitin](#)

Followed by: [UBA6 conjugates ubiquitin to UBA6 in the cytosol](#)

Literature references

Li, X., Gygi, SP., Jin, J., Harper, JW. (2007). Dual E1 activation systems for ubiquitin differentially regulate E2 enzyme charging. *Nature*, 447, 1135-8. ↗

Hofmann, K., Pelzer, C., Groettrup, M., Schmidtke, G. (2008). Activating the ubiquitin family: UBA6 challenges the field. *Trends Biochem. Sci.*, 33, 230-7. ↗

Pelzer, C., Singh, RK., Groettrup, M., Scheffner, M., Matentzoglou, K., Schmidtke, G. et al. (2007). UBE1L2, a novel E1 enzyme specific for ubiquitin. *J. Biol. Chem.*, 282, 23010-4. ↗

Editions

2016-01-12	Authored, Edited	May, B.
2016-08-11	Reviewed	Azevedo, JE.

UBA6 conjugates ubiquitin to UBA6 in the cytosol ↗

Location: [Synthesis of active ubiquitin: roles of E1 and E2 enzymes](#)

Stable identifier: R-HSA-8865098

Type: transition

Compartments: cytosol

Inferred from: [UBA1 conjugates ubiquitin to UBA1 in the cytosol \(Homo sapiens\)](#)

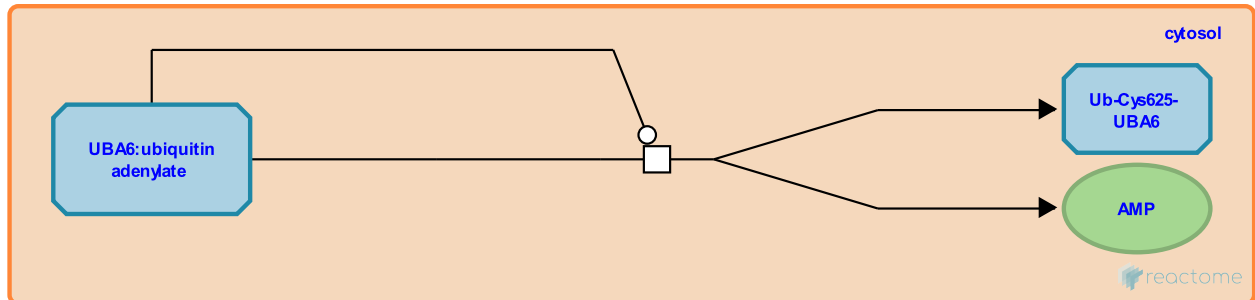

As inferred from the homologous UBA1, activation of ubiquitin by UBA6 (UBE1L1) proceeds through 3 steps: adenylation of ubiquitin, conjugation of ubiquitin from adenylation-ubiquitin to an internal cysteine residue of UBA6, and adenylation of a second molecule of ubiquitin. In the second step, the thiol group of an internal cysteine residue of UBA6 attacks the acyl-adenyl bond of the C-terminal glycine of adenylation-ubiquitin, resulting in a thioester bond between the cysteine residue and the C-terminal glycine of ubiquitin (Jin et al. 2007, Pelzer et al. 2007, reviewed in Groettrup et al. 2008).

Preceded by: [UBA6 adenylates ubiquitin in the cytosol](#)

Followed by: [Ub-Cys625-UBA6 adenylates ubiquitin in the cytosol](#)

Literature references

Li, X., Gygi, SP., Jin, J., Harper, JW. (2007). Dual E1 activation systems for ubiquitin differentially regulate E2 enzyme charging. *Nature*, 447, 1135-8. ↗

Hofmann, K., Pelzer, C., Groettrup, M., Schmidtke, G. (2008). Activating the ubiquitin family: UBA6 challenges the field. *Trends Biochem. Sci.*, 33, 230-7. ↗

Pelzer, C., Singh, RK., Groettrup, M., Scheffner, M., Matentzoglou, K., Schmidtke, G. et al. (2007). UBE1L2, a novel E1 enzyme specific for ubiquitin. *J. Biol. Chem.*, 282, 23010-4. ↗

Editions

2016-01-12	Authored, Edited	May, B.
2016-08-11	Reviewed	Azevedo, JE.

Ub-Cys625-UBA6 adenylates ubiquitin in the cytosol ↗

Location: [Synthesis of active ubiquitin: roles of E1 and E2 enzymes](#)

Stable identifier: R-HSA-8865050

Type: transition

Compartments: cytosol

Inferred from: [Ub-Cys632-UBA1 adenylates ubiquitin in the cytosol \(Homo sapiens\)](#)

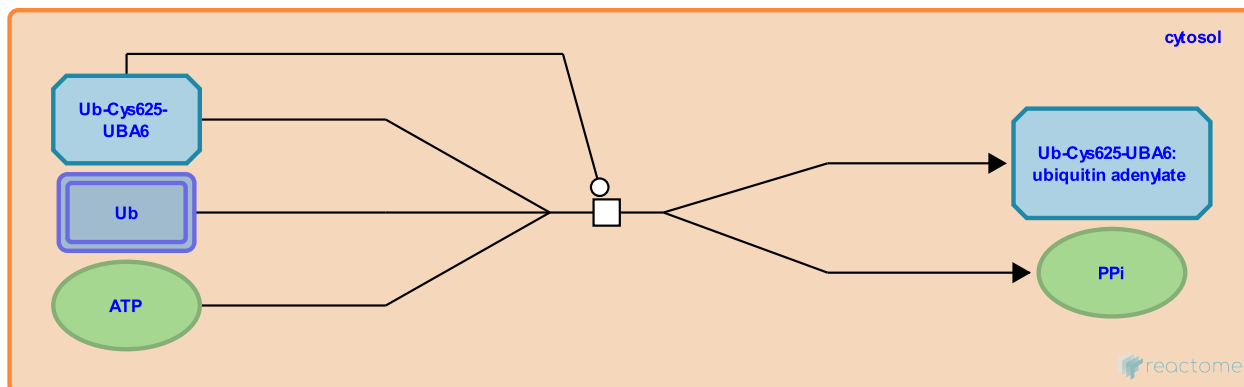

As inferred from the homologous UBA1, activation of ubiquitin by UBA6 (UBE1L1) proceeds through 3 steps: adenylation of ubiquitin, conjugation of ubiquitin from adeny-ubiquitin to an internal cysteine residue of UBA6, and adenylation of a second molecule of ubiquitin. In the third step, the UBA6-ubiquitin conjugate adenylates the C-terminal glycine of a second ubiquitin molecule. This results in UBA6 loaded with 2 ubiquitin molecules, one of which is conjugated to an internal cysteine residue of UBA6 and one of which is adenylated and non-covalently bound to UBA6 (Jin et al. 2007, Pelzer et al. 2007, reviewed in Groettrup et al. 2008).

Preceded by: [UBA6 conjugates ubiquitin to UBA6 in the cytosol](#)

Followed by: [UBA6 conjugates ubiquitin to cytosolic E2 enzymes](#)

Literature references

Li, X., Gygi, SP., Jin, J., Harper, JW. (2007). Dual E1 activation systems for ubiquitin differentially regulate E2 enzyme charging. *Nature*, 447, 1135-8. ↗

Hofmann, K., Pelzer, C., Groettrup, M., Schmidtke, G. (2008). Activating the ubiquitin family: UBA6 challenges the field. *Trends Biochem. Sci.*, 33, 230-7. ↗

Pelzer, C., Singh, RK., Groettrup, M., Scheffner, M., Matentzoglou, K., Schmidtke, G. et al. (2007). UBE1L2, a novel E1 enzyme specific for ubiquitin. *J. Biol. Chem.*, 282, 23010-4. ↗

Editions

2016-01-12	Authored, Edited	May, B.
2016-08-11	Reviewed	Azevedo, JE.

UBA6 conjugates ubiquitin to cytosolic E2 enzymes ↗

Location: [Synthesis of active ubiquitin: roles of E1 and E2 enzymes](#)

Stable identifier: R-HSA-8852127

Type: transition

Compartments: cytosol

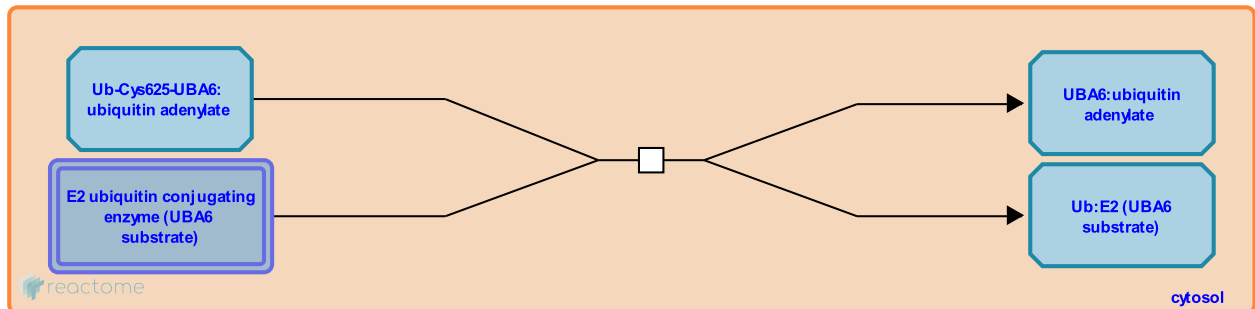

In the cytosol, the UBA6-ubiquitin thiol ester conjugate transfers ubiquitin from UBA6 to an internal cysteine residue of the E2 enzyme, forming a thiol ester conjugate between ubiquitin and the cysteine residue of E2 (Jin et al. 2007, inferred from the rabbit homologue in Hershko et al. 1983, reviewed in Groettrup et al. 2008). As inferred from UBA1, the E2 then disengages from UBA6 (Eletr et al. 2005).

Preceded by: [Ub-Cys625-UBA6 adenylates ubiquitin in the cytosol](#)

Literature references

- Li, X., Gygi, SP., Jin, J., Harper, JW. (2007). Dual E1 activation systems for ubiquitin differentially regulate E2 enzyme charging. *Nature*, 447, 1135-8. ↗
- Hofmann, K., Pelzer, C., Groettrup, M., Schmidtke, G. (2008). Activating the ubiquitin family: UBA6 challenges the field. *Trends Biochem. Sci.*, 33, 230-7. ↗
- Pelzer, C., Singh, RK., Groettrup, M., Scheffner, M., Matentzoglou, K., Schmidtke, G. et al. (2007). UBE1L2, a novel E1 enzyme specific for ubiquitin. *J. Biol. Chem.*, 282, 23010-4. ↗
- Huang, DT., Kuhlman, B., Duda, DM., Schulman, BA., Eletr, ZM. (2005). E2 conjugating enzymes must disengage from their E1 enzymes before E3-dependent ubiquitin and ubiquitin-like transfer. *Nat. Struct. Mol. Biol.*, 12, 933-4. ↗

Editions

2016-01-12	Authored, Edited	May, B.
2016-08-11	Reviewed	Azevedo, JE.

UBA1 adenylates ubiquitin in the nucleoplasm ↗

Location: [Synthesis of active ubiquitin: roles of E1 and E2 enzymes](#)

Stable identifier: R-HSA-8852128

Type: binding

Compartments: nucleoplasm

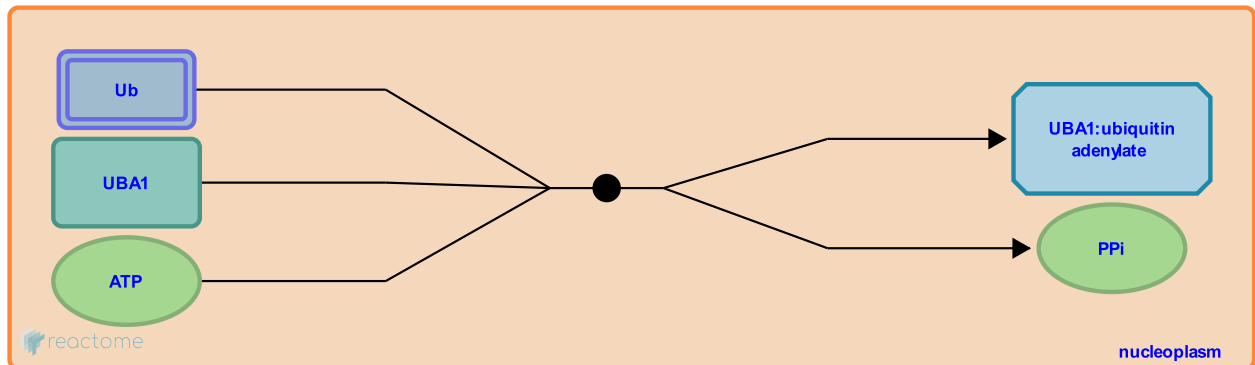

UBA1 is present in both the cytosol and nucleoplasm (Grenfell et al. 1994). Activation of ubiquitin by UBA1 proceeds through 3 steps: adenylation of ubiquitin, conjugation of ubiquitin from adenylyl-ubiquitin to an internal cysteine residue of UBA1, and adenylation of a second molecule of ubiquitin. In the first step, the adenylation module of UBA1 catalyzes the acyl-adenylation of the C-terminal glycine of ubiquitin (Jin et al. 2007, inferred from the rabbit homologue in Haas et al. 1982, Hershko et al. 1983, reviewed in Groettrup et al. 2008).

Followed by: [UBA1 conjugates ubiquitin to UBA1 in the nucleus](#)

Literature references

- Li, X., Gygi, SP., Jin, J., Harper, JW. (2007). Dual E1 activation systems for ubiquitin differentially regulate E2 enzyme charging. *Nature*, 447, 1135-8. ↗
- Hofmann, K., Pelzer, C., Groettrup, M., Schmidtke, G. (2008). Activating the ubiquitin family: UBA6 challenges the field. *Trends Biochem. Sci.*, 33, 230-7. ↗
- Rose, IA., Hershko, A., Haas, AL., Warms, JV. (1982). Ubiquitin-activating enzyme. Mechanism and role in protein-ubiquitin conjugation. *J. Biol. Chem.*, 257, 2543-8. ↗
- Ciechanover, A., Elias, S., Heller, H., Hershko, A. (1983). Components of ubiquitin-protein ligase system. Resolution, affinity purification, and role in protein breakdown. *J. Biol. Chem.*, 258, 8206-14. ↗
- Schwartz, AL., Ciechanover, A., Grenfell, SJ., Handley-Gearhart, PM., Trausch-Azar, JS. (1994). Nuclear localization of the ubiquitin-activating enzyme, E1, is cell-cycle-dependent. *Biochem. J.*, 300, 701-8. ↗

Editions

2016-01-12	Authored, Edited	May, B.
2016-08-11	Reviewed	Azevedo, JE.

UBA1 conjugates ubiquitin to UBA1 in the nucleus ↗

Location: [Synthesis of active ubiquitin: roles of E1 and E2 enzymes](#)

Stable identifier: R-HSA-8852136

Type: dissociation

Compartments: nucleoplasm

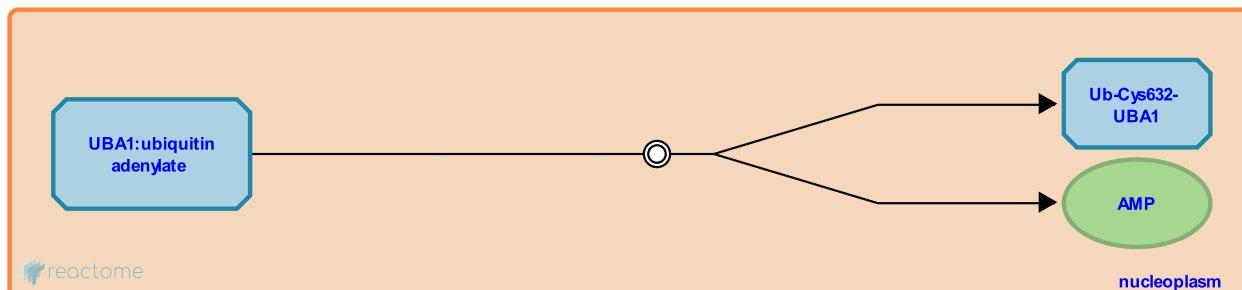

UBA1 is located in both the nucleus and cytoplasm (Grenfell 1994). Activation of ubiquitin by UBA1 proceeds through 3 steps: adenylation of ubiquitin, conjugation of ubiquitin from adenyli-ubiquitin to an internal cysteine residue of UBA1, and adenylation of a second molecule of ubiquitin. In the second step, the thiol group of an internal cysteine residue of UBA1 attacks the acyl-adenyl bond of the C-terminal glycine of adenylated ubiquitin, resulting in a thioester bond between the cysteine residue and the C-terminal glycine of ubiquitin (Jin et al. 2007, inferred from the rabbit homologue in Haas et al. 1982, Hershko et al. 1983, reviewed in Groettrup et al. 2008).

Preceded by: [UBA1 adenylates ubiquitin in the nucleoplasm](#)

Followed by: [Ub-Cys632-UBA1 adenylates ubiquitin in the nucleus](#)

Literature references

- Li, X., Gygi, SP., Jin, J., Harper, JW. (2007). Dual E1 activation systems for ubiquitin differentially regulate E2 enzyme charging. *Nature*, 447, 1135-8. ↗
- Hofmann, K., Pelzer, C., Groettrup, M., Schmidtke, G. (2008). Activating the ubiquitin family: UBA6 challenges the field. *Trends Biochem. Sci.*, 33, 230-7. ↗
- Rose, IA., Hershko, A., Haas, AL., Warmus, JV. (1982). Ubiquitin-activating enzyme. Mechanism and role in protein-ubiquitin conjugation. *J. Biol. Chem.*, 257, 2543-8. ↗
- Ciechanover, A., Elias, S., Heller, H., Hershko, A. (1983). Components of ubiquitin-protein ligase system. Resolution, affinity purification, and role in protein breakdown. *J. Biol. Chem.*, 258, 8206-14. ↗
- Schwartz, AL., Ciechanover, A., Grenfell, SJ., Handley-Gearhart, PM., Trausch-Azar, JS. (1994). Nuclear localization of the ubiquitin-activating enzyme, E1, is cell-cycle-dependent. *Biochem. J.*, 300, 701-8. ↗

Editions

2016-01-12	Authored, Edited	May, B.
2016-08-11	Reviewed	Azevedo, JE.

Ub-Cys632-UBA1 adenylates ubiquitin in the nucleus ↗

Location: [Synthesis of active ubiquitin: roles of E1 and E2 enzymes](#)

Stable identifier: R-HSA-8852131

Type: binding

Compartments: nucleoplasm

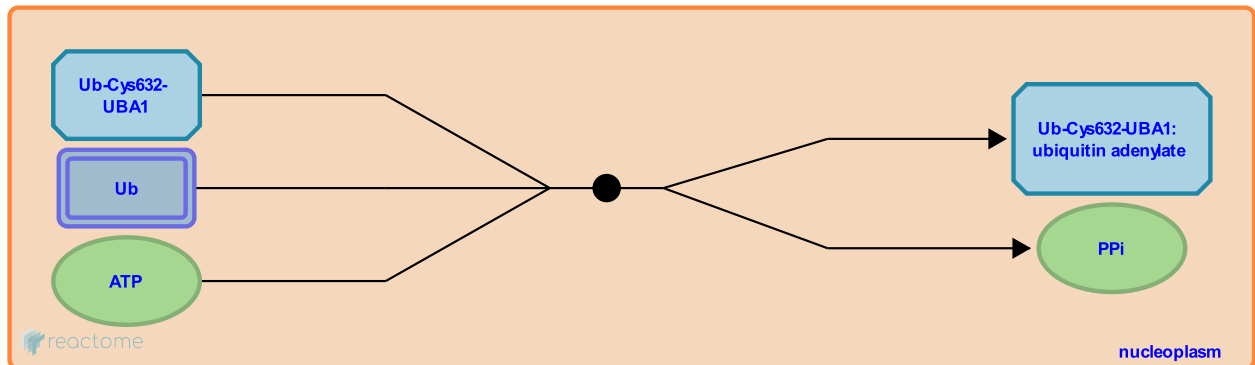

UBA1 is located in both the cytoplasm and nucleus (Grenfell et al. 1994). Activation of ubiquitin by UBA1 proceeds through 3 steps: adenylation of ubiquitin, conjugation of ubiquitin from adenylation-ubiquitin to an internal cysteine residue of UBA1, and adenylation of a second molecule of ubiquitin. In the third step, the UBA1-ubiquitin conjugate adenylates the C-terminal glycine of a second ubiquitin molecule. This results in UBA1 loaded with 2 ubiquitin molecules, one of which is conjugated to an internal cysteine residue of UBA1 and one of which is adenylated and non-covalently bound to UBA1 (Jin et al. 2007, inferred from the rabbit homologue in Haas et al. 1982, Hershko et al. 1983, reviewed in Groettrup et al. 2008)

Preceded by: [UBA1 conjugates ubiquitin to UBA1 in the nucleus](#)

Followed by: [UBA1 conjugates ubiquitin to nuclear E2 enzymes](#)

Literature references

- Li, X., Gygi, SP., Jin, J., Harper, JW. (2007). Dual E1 activation systems for ubiquitin differentially regulate E2 enzyme charging. *Nature*, 447, 1135-8. ↗
- Hofmann, K., Pelzer, C., Groettrup, M., Schmidtke, G. (2008). Activating the ubiquitin family: UBA6 challenges the field. *Trends Biochem. Sci.*, 33, 230-7. ↗
- Rose, IA., Hershko, A., Haas, AL., Warmus, JV. (1982). Ubiquitin-activating enzyme. Mechanism and role in protein-ubiquitin conjugation. *J. Biol. Chem.*, 257, 2543-8. ↗
- Ciechanover, A., Elias, S., Heller, H., Hershko, A. (1983). Components of ubiquitin-protein ligase system. Resolution, affinity purification, and role in protein breakdown. *J. Biol. Chem.*, 258, 8206-14. ↗
- Schwartz, AL., Ciechanover, A., Grenfell, SJ., Handley-Gearhart, PM., Trausch-Azar, JS. (1994). Nuclear localization of the ubiquitin-activating enzyme, E1, is cell-cycle-dependent. *Biochem. J.*, 300, 701-8. ↗

Editions

2016-01-12	Authored, Edited	May, B.
2016-08-11	Reviewed	Azevedo, JE.

UBA1 conjugates ubiquitin to nuclear E2 enzymes ↗

Location: [Synthesis of active ubiquitin: roles of E1 and E2 enzymes](#)

Stable identifier: R-HSA-8852130

Type: transition

Compartments: nucleoplasm

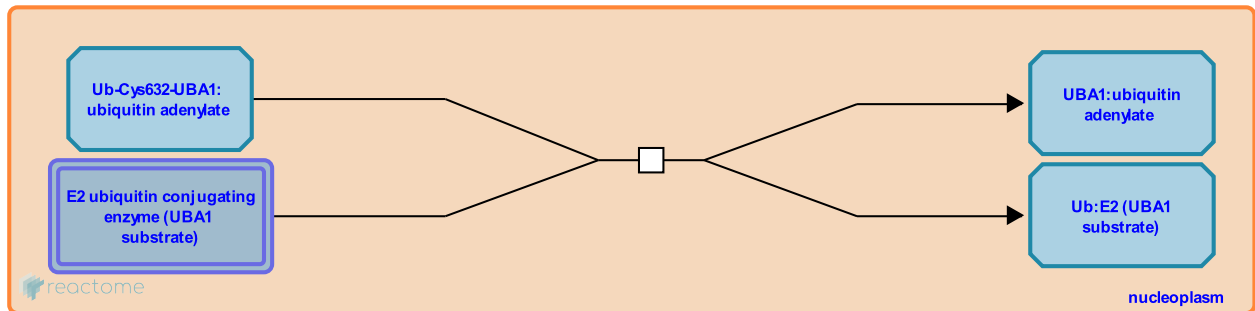

In the nucleus (Grenfell et al. 1994), the UBA1-ubiquitin thiol ester conjugate transfers ubiquitin from UBA1 to an internal cysteine residue of the E2 enzyme, forming a thiol ester conjugate between ubiquitin and the cysteine residue of E2 (Jin et al. 2007, inferred from the rabbit homologue in Hershko et al. 1983, reviewed in Groettrup et al. 2008). The E2 then disengages from UBA1 (Eletr et al. 2005).

Preceded by: [Ub-Cys632-UBA1 adenylates ubiquitin in the nucleus](#)

Literature references

- Li, X., Gygi, SP., Jin, J., Harper, JW. (2007). Dual E1 activation systems for ubiquitin differentially regulate E2 enzyme charging. *Nature*, 447, 1135-8. ↗
- Hofmann, K., Pelzer, C., Groettrup, M., Schmidtke, G. (2008). Activating the ubiquitin family: UBA6 challenges the field. *Trends Biochem. Sci.*, 33, 230-7. ↗
- Ciechanover, A., Elias, S., Heller, H., Hershko, A. (1983). Components of ubiquitin-protein ligase system. Resolution, affinity purification, and role in protein breakdown. *J. Biol. Chem.*, 258, 8206-14. ↗
- Schwartz, AL., Ciechanover, A., Grenfell, SJ., Handley-Gearhart, PM., Trausch-Azar, JS. (1994). Nuclear localization of the ubiquitin-activating enzyme, E1, is cell-cycle-dependent. *Biochem. J.*, 300, 701-8. ↗
- Huang, DT., Kuhlman, B., Duda, DM., Schulman, BA., Eletr, ZM. (2005). E2 conjugating enzymes must disengage from their E1 enzymes before E3-dependent ubiquitin and ubiquitin-like transfer. *Nat. Struct. Mol. Biol.*, 12, 933-4. ↗

Editions

2016-01-12	Authored, Edited	May, B.
2016-08-11	Reviewed	Azevedo, JE.

Table of Contents

Introduction	1
☰ Synthesis of active ubiquitin: roles of E1 and E2 enzymes	2
↳ OTULIN, USP5 cleaves UBB yielding ubiquitin	3
↳ OTULIN, USP5 cleaves UBC yielding ubiquitin	4
↳ UCHL3, USP7, USP9X cleaves UBA52 yielding ubiquitin	5
↳ UCHL3, USP7, USP9X cleaves RPS27A yielding ubiquitin	6
↳ UBA1 adenylates ubiquitin in the cytosol	7
↳ UBA1 conjugates ubiquitin to UBA1 in the cytosol	8
↳ Ub-Cys632-UBA1 adenylates ubiquitin in the cytosol	9
↳ UBA1 conjugates ubiquitin to cytosolic E2 enzymes	10
↳ UBA6 adenylates ubiquitin in the cytosol	11
↳ UBA6 conjugates ubiquitin to UBA6 in the cytosol	12
↳ Ub-Cys625-UBA6 adenylates ubiquitin in the cytosol	13
↳ UBA6 conjugates ubiquitin to cytosolic E2 enzymes	14
↳ UBA1 adenylates ubiquitin in the nucleoplasm	15
↳ UBA1 conjugates ubiquitin to UBA1 in the nucleus	16
↳ Ub-Cys632-UBA1 adenylates ubiquitin in the nucleus	17
↳ UBA1 conjugates ubiquitin to nuclear E2 enzymes	18
Table of Contents	19