

Phosphate bond hydrolysis by NTPDase proteins

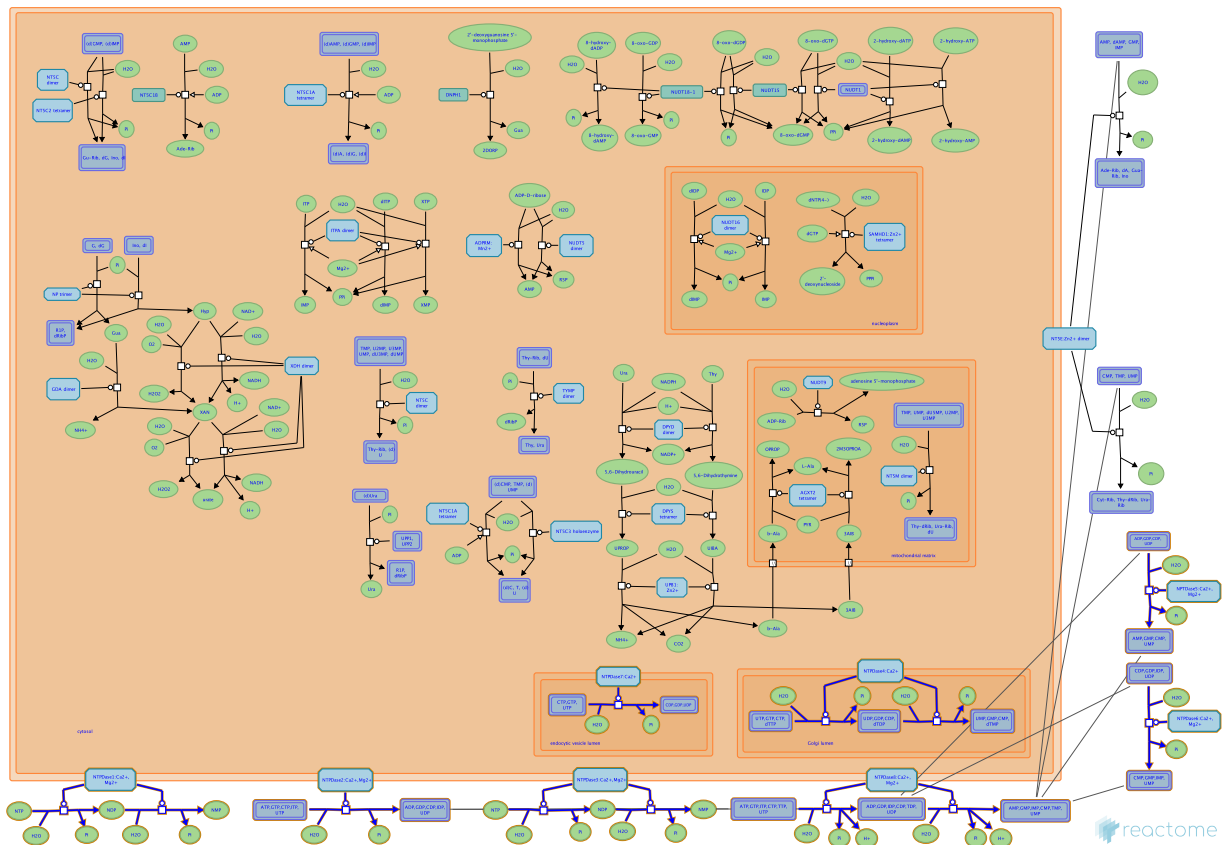

Orlic-Milacic, M., Sévigny, J.

European Bioinformatics Institute, New York University Langone Medical Center, Ontario Institute for Cancer Research, Oregon Health and Science University.

The contents of this document may be freely copied and distributed in any media, provided the authors, plus the institutions, are credited, as stated under the terms of [Creative Commons Attribution 4.0 International \(CC BY 4.0\) License](https://creativecommons.org/licenses/by/4.0/). For more information see our [license](https://creativecommons.org/licenses/by/4.0/).

Introduction

Reactome is open-source, open access, manually curated and peer-reviewed pathway database. Pathway annotations are authored by expert biologists, in collaboration with Reactome editorial staff and cross-referenced to many bioinformatics databases. A system of evidence tracking ensures that all assertions are backed up by the primary literature. Reactome is used by clinicians, geneticists, genomics researchers, and molecular biologists to interpret the results of high-throughput experimental studies, by bioinformaticians seeking to develop novel algorithms for mining knowledge from genomic studies, and by systems biologists building predictive models of normal and disease variant pathways.

The development of Reactome is supported by grants from the US National Institutes of Health (P41 HG003751), University of Toronto (CFREF Medicine by Design), European Union (EU STRP, EMI-CD), and the European Molecular Biology Laboratory (EBI Industry program).

Literature references

- Fabregat, A., Sidiropoulos, K., Viteri, G., Forner, O., Marin-Garcia, P., Arnau, V. et al. (2017). Reactome pathway analysis: a high-performance in-memory approach. *BMC bioinformatics*, 18, 142. [↗](#)
- Sidiropoulos, K., Viteri, G., Sevilla, C., Jupe, S., Webber, M., Orlic-Milacic, M. et al. (2017). Reactome enhanced pathway visualization. *Bioinformatics*, 33, 3461-3467. [↗](#)
- Fabregat, A., Jupe, S., Matthews, L., Sidiropoulos, K., Gillespie, M., Garapati, P. et al. (2018). The Reactome Pathway Knowledgebase. *Nucleic Acids Res*, 46, D649-D655. [↗](#)
- Fabregat, A., Korninger, F., Viteri, G., Sidiropoulos, K., Marin-Garcia, P., Ping, P. et al. (2018). Reactome graph database: Efficient access to complex pathway data. *PLoS computational biology*, 14, e1005968. [↗](#)

Reactome database release: 77

This document contains 1 pathway and 12 reactions ([see Table of Contents](#))

Phosphate bond hydrolysis by NTPDase proteins ↗

Stable identifier: R-HSA-8850843

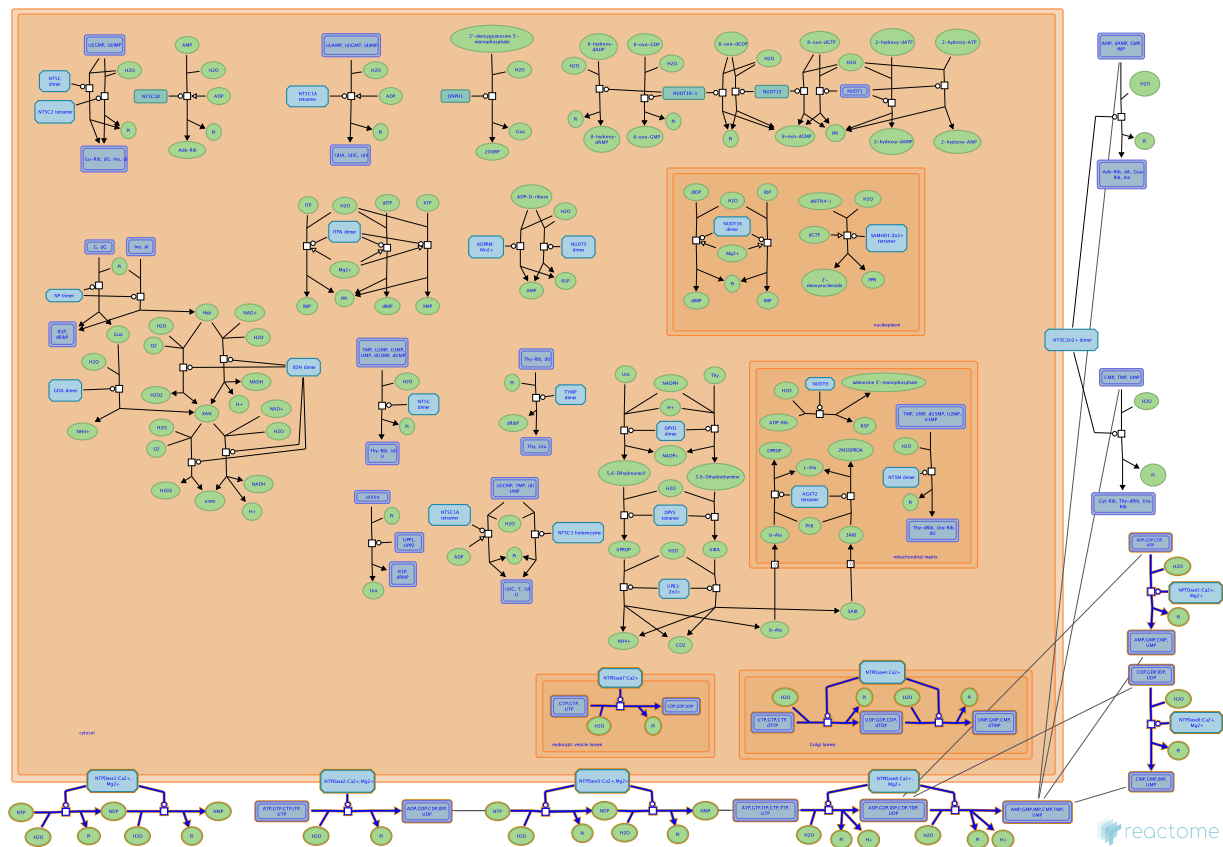

The ectonucleoside triphosphate diphosphatase (E-NTPDase family) of ectonucleotidases includes 8 enzymes: NTPDase1 (encoded by the ENTPD1 gene), NTPDase2 (encoded by the ENTPD2 gene), NTPDase3 (encoded by the ENTPD3 gene), NTPDase4 (encoded by the ENTPD4 gene), NTPDase5 (encoded by the ENTPD5 gene), NTPDase6 (encoded by the ENTPD6 gene), NTPDase7 (encoded by the ENTPD7 gene) and NTPDase8 (encoded by the ENTPD8 gene). NTPDases hydrolyze nucleoside triphosphates and nucleoside diphosphates, producing the corresponding nucleoside monophosphates as final products. Different family members show different specificity for particular nucleotides. NTPDases are involved in various biological processes, such as hemostasis, immune response and development of the nervous system.

The catalytic domain of NTPDases is contained within the loop formed by a cluster of apyrase conserved regions (ACRs). All family members require divalent cations, such as calcium (Ca²⁺) or magnesium (Mg²⁺) ions, for catalytic activity. The hydrolysis involves a nucleophilic attack of a water molecule on the terminal phosphate of a nucleotide substrate.

All E-NTPDase family members are transmembrane proteins, associated with either plasma membrane (NTPDase1, NTPDase2, NTPDase3 and NTPDase8) or organelle membranes (NTPDase4 and NTPDase7). Two family members, NTPDase5 and NTPDase6, can be secreted into extracellular space following a proteolytic cleavage from the plasma membrane. NTPDases hydrolyze exocyttoplasmic nucleotides, thus regulating the availability of ligands for purinergic receptors. Glycosylation and oligomerization are involved in the regulation of NTPDases, but have not been thoroughly studied.

For reviews of the NTPDase family, please refer to Robson et al. 2006 and Zimmermann et al. 2012.

Literature references

Zimmermann, H., Zebisch, M., Sträter, N. (2012). Cellular function and molecular structure of ecto-nucleotidases. *Purinergic Signal.*, 8, 437-502. [↗](#)

Robson, SC., Sévigny, J., Zimmermann, H. (2006). The E-NTPDase family of ectonucleotidases: Structure function relationships and pathophysiological significance. *Purinergic Signal.*, 2, 409-30. [↗](#)

Editions

2015-12-30	Authored, Edited	Orlic-Milacic, M.
2016-05-11	Reviewed	Sévigny, J.

NTPDase1 hydrolyzes nucleoside triphosphates ↗

Location: [Phosphate bond hydrolysis by NTPDase proteins](#)

Stable identifier: R-HSA-8850846

Type: transition

Compartments: extracellular region, plasma membrane

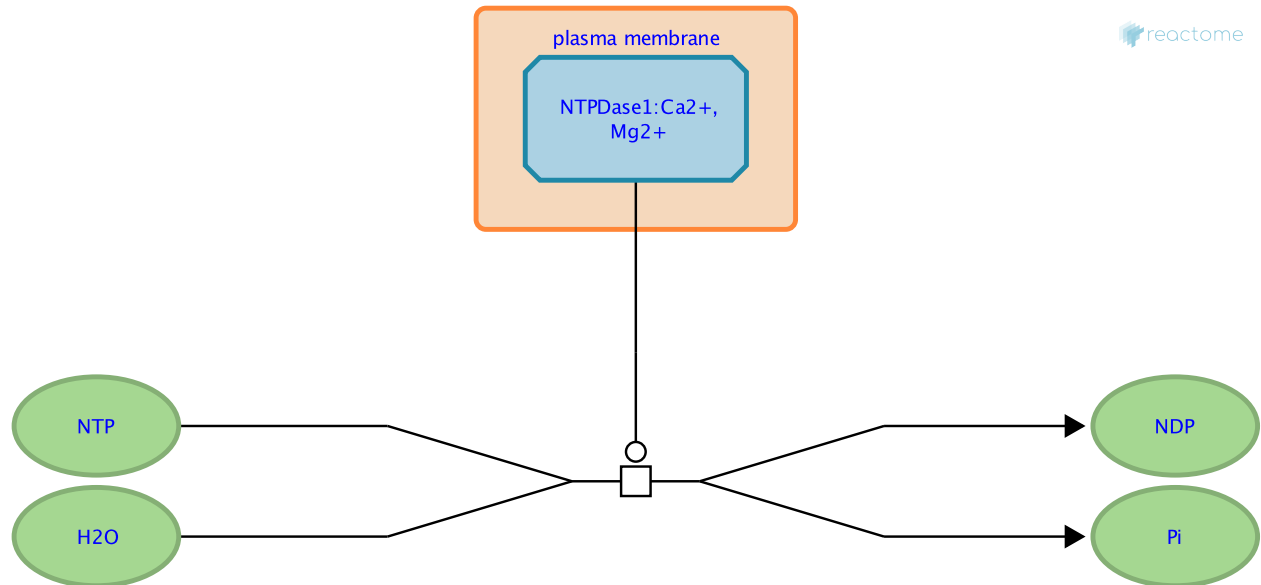

NTPDase1 (CD39) is a plasma membrane-bound ectonucleotidase encoded by the ENTPD1 gene that hydrolyzes extracellular NTPs to NMPs, via corresponding NDP intermediates (Lemmens et al. 2000, Kukulski et al. 2005). NTPDase1 is expressed on endothelial cells, smooth muscle cells and most leukocytes. The vascular endothelial NTPDase1 regulates platelet aggregation and thrombosis (Kaczmarek et al. 1996, Enjyoji et al. 1999). In mice, NTPDase1 is expressed at the surface of epidermal dendritic cells (Langerhans cells) and is involved in regulation of immune response to skin irritants (Mizumoto et al. 2002). NTPDase1 expressed in vascular smooth muscle cells regulates vasomotion (Kauffenstein et al. 2010, reviewed by Kukulski et al. 2011). In regulatory T lymphocytes (Tregs) and other leukocytes NTPDase1 regulates inflammatory processes (Deaglio et al. 2007).

Followed by: [NTPDase1 hydrolyzes nucleoside diphosphates](#), [NTPDase5 hydrolyzes nucleoside diphosphates](#)

Literature references

- Kaczmarek, E., Koziak, K., Sévigny, J., Siegel, JB., Anrather, J., Beaudoin, AR. et al. (1996). Identification and characterization of CD39/vascular ATP diphosphohydrolase. *J Biol Chem*, 271, 33116-22. ↗
- Mizumoto, N., Kumamoto, T., Robson, SC., Sévigny, J., Matsue, H., Enjyoji, K. et al. (2002). CD39 is the dominant Langerhans cell-associated ecto-NTPDase: modulatory roles in inflammation and immune responsiveness. *Nat. Med.*, 8, 358-65. ↗
- Lemmens, R., Vanduffel, L., Kittel, A., Beaudoin, AR., Benrezzak, O., Sévigny, J. (2000). Distribution, cloning, and characterization of porcine nucleoside triphosphate diphosphohydrolase-1. *Eur. J. Biochem.*, 267, 4106-14. ↗
- Deaglio, S., Dwyer, KM., Gao, W., Friedman, D., Usheva, A., Erat, A. et al. (2007). Adenosine generation catalyzed by CD39 and CD73 expressed on regulatory T cells mediates immune suppression. *J. Exp. Med.*, 204, 1257-65. ↗
- Kukulski, F., Lévesque, SA., Lavoie, EG., Lecka, J., Bigonnesse, F., Knowles, AF. et al. (2005). Comparative hydrolysis of P2 receptor agonists by NTPDases 1, 2, 3 and 8. *Purinergic Signal.*, 1, 193-204. ↗

Editions

2015-12-30	Authored, Edited	Orlic-Milacic, M.
2016-05-11	Reviewed	Sévigny, J.

NTPDase1 hydrolyzes nucleoside diphosphates ↗

Location: [Phosphate bond hydrolysis by NTPDase proteins](#)

Stable identifier: R-HSA-8850854

Type: transition

Compartments: plasma membrane, extracellular region

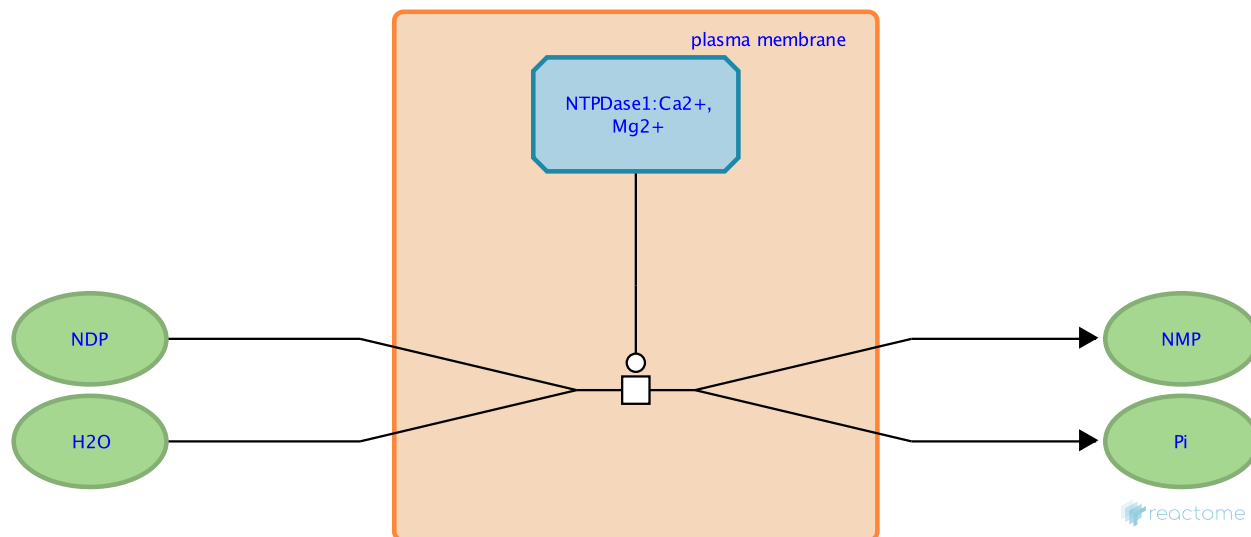

NTPDase1 (CD39), a plasma membrane-bound nucleotide phosphatase encoded by the ENTPD1 gene, hydrolyzes extracellular NDPs to corresponding NMPs (Lemmens et al. 2000, Kukulski et al. 2005) which contributes to inhibition of platelet aggregation and thrombosis (Kaczmarek et al. 1996, Enjyoji et al. 1999, Marcus et al. 2003).

Preceded by: [NTPDase1 hydrolyzes nucleoside triphosphates](#)

Literature references

- Kaczmarek, E., Koziak, K., Sévigny, J., Siegel, JB., Anrather, J., Beaudoin, AR. et al. (1996). Identification and characterization of CD39/vascular ATP diphosphohydrolase. *J Biol Chem*, 271, 33116-22. ↗
- Lemmens, R., Vanduffel, L., Kittel, A., Beaudoin, AR., Benrezzak, O., Sévigny, J. (2000). Distribution, cloning, and characterization of porcine nucleoside triphosphate diphosphohydrolase-1. *Eur. J. Biochem.*, 267, 4106-14. ↗
- Kukulski, F., Lévesque, SA., Lavoie, EG., Lecka, J., Bigonnesse, F., Knowles, AF. et al. (2005). Comparative hydrolysis of P2 receptor agonists by NTPDases 1, 2, 3 and 8. *Purinergic Signal.*, 1, 193-204. ↗
- Enjyoji, K., Sévigny, J., Lin, Y., Frenette, PS., Christie, PD., Esch, JS. et al. (1999). Targeted disruption of cd39/ATP diphosphohydrolase results in disordered hemostasis and thromboregulation. *Nat. Med.*, 5, 1010-7. ↗
- Marcus, AJ., Broekman, MJ., Drosopoulos, JH., Islam, N., Pinsky, DJ., Sesti, C. et al. (2003). Heterologous cell-cell interactions: thromboregulation, cerebroprotection and cardioprotection by CD39 (NTPDase-1). *J. Thromb. Haemost.*, 1, 2497-509. ↗

Editions

2015-12-30	Authored, Edited	Orlic-Milacic, M.
2016-05-11	Reviewed	Sévigny, J.

NTPDase2 hydrolyzes nucleoside triphosphates ↗

Location: [Phosphate bond hydrolysis by NTPDase proteins](#)

Stable identifier: R-HSA-8851089

Type: transition

Compartments: extracellular region, plasma membrane

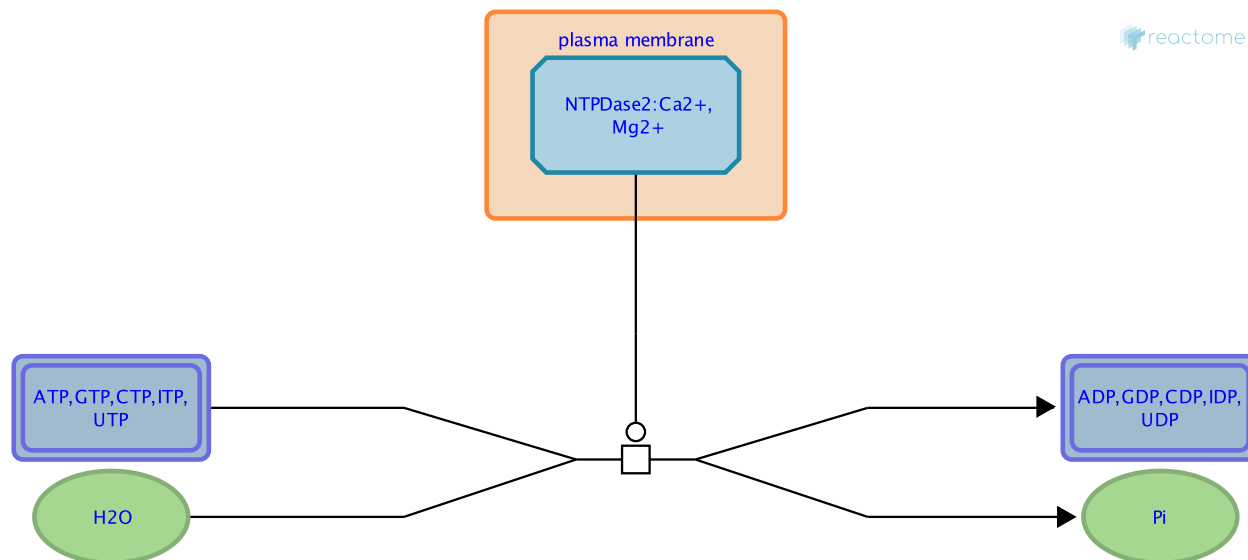

NTPDase2 (CD39L1), encoded by the ENTPD2 gene, is an ectonucleoside triphosphate diphosphohydrolase that is expressed at the plasma membrane where it hydrolyzes extracellular nucleoside triphosphates (ATP, GTP, CTP, ITP, UTP) to the respective nucleoside diphosphate (ADP, GDP, CDP, IDP, UDP) in the presence of Ca²⁺ or Mg²⁺ ions. NTPDase2 is only marginally active in hydrolyzing nucleoside diphosphates, such as ADP and UDP (Kegel et al. 1997, Kirley et al. 1997, Mateo et al. 1999). The alpha splicing isoform of NTPDase2 is expressed at the plasma membrane, while beta and gamma isoforms are expressed in the endoplasmic reticulum (Mateo et al. 2003). NTPDase2 may oligomerize and the oligomerization state may affect substrate specificity (Failer et al. 2003).

NTPDase2 may contribute to vascular hemostasis by exerting an opposing role to NTPDase1 (Sévigny et al. 2002).

Literature references

Mateo, J., Harden, TK., Boyer, JL. (1999). Functional expression of a cDNA encoding a human ecto-ATPase. *Br. J. Pharmacol.*, 128, 396-402. ↗

Mateo, J., Kreda, S., Henry, CE., Harden, TK., Boyer, JL. (2003). Requirement of Cys399 for processing of the human ecto-ATPase (NTPDase2) and its implications for determination of the activities of splice variants of the enzyme. *J. Biol. Chem.*, 278, 39960-8. ↗

Failer, BU., Aschrafi, A., Schmalzing, G., Zimmermann, H. (2003). Determination of native oligomeric state and substrate specificity of rat NTPDase1 and NTPDase2 after heterologous expression in *Xenopus* oocytes. *Eur. J. Biochem.*, 270, 1802-9. ↗

Kirley, TL. (1997). Complementary DNA cloning and sequencing of the chicken muscle ecto-ATPase. Homology with the lymphoid cell activation antigen CD39. *J. Biol. Chem.*, 272, 1076-81. ↗

Kegel, B., Braun, N., Heine, P., Maliszewski, CR., Zimmermann, H. (1997). An ecto-ATPase and an ecto-ATP diphosphohydrolase are expressed in rat brain. *Neuropharmacology*, 36, 1189-200. ↗

Editions

2015-12-30	Authored, Edited	Orlic-Milacic, M.
2016-05-11	Reviewed	Sévigny, J.

NTPDase3 hydrolyzes nucleoside triphosphates ↗

Location: [Phosphate bond hydrolysis by NTPDase proteins](#)

Stable identifier: R-HSA-8851110

Type: transition

Compartments: extracellular region, plasma membrane

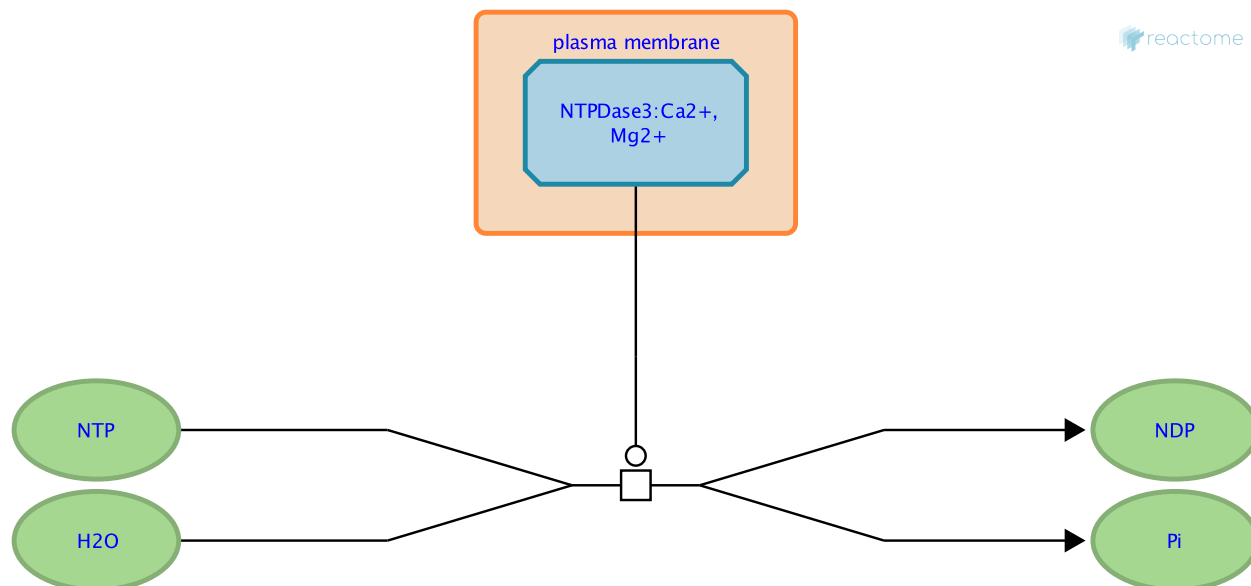

NTPDase3 (CD39L3), encoded by the ENTPD3 gene, is a plasma membrane-bound ectonucleotidase that hydrolyzes extracellular NTPs to NMPs via corresponding NDP intermediates (Smith and Kirley 1998, Lavoie et al. 2004, Kukulski et al. 2005). NTPDase3 is about 3 times more efficient in hydrolyzing ATP than ADP (Smith and Kirley 1998). NTPDase3 is expressed in some neurons (Belcher et al. 2006, Lavoie et al. 2010) where it may be involved in sleep-wake behaviour (Belcher et al. 2006). NTPDase3 is also expressed in islet cells where it may regulate insulin secretion (Lavoie et al. 2010).

Followed by: [NTPDase3 hydrolyzes nucleoside diphosphates](#)

Literature references

- Smith, TM., Kirley, TL. (1998). Cloning, sequencing, and expression of a human brain ecto-apyrase related to both the ecto-ATPases and CD39 ecto-apyrases1. *Biochim. Biophys. Acta*, 1386, 65-78. ↗
- Kukulski, F., Lévesque, SA., Lavoie, EG., Lecka, J., Bigonnesse, F., Knowles, AF. et al. (2005). Comparative hydrolysis of P2 receptor agonists by NTPDases 1, 2, 3 and 8. *Purinergic Signal.*, 1, 193-204. ↗
- Lavoie, EG., Kukulski, F., Lévesque, SA., Lecka, J., Sévigny, J. (2004). Cloning and characterization of mouse nucleoside triphosphate diphosphohydrolase-3. *Biochem. Pharmacol.*, 67, 1917-26. ↗
- Lavoie, EG., Fausther, M., Kauffenstein, G., Kukulski, F., Künzli, BM., Friess, H. et al. (2010). Identification of the ectonucleotidases expressed in mouse, rat, and human Langerhans islets: potential role of NTPDase3 in insulin secretion. *Am. J. Physiol. Endocrinol. Metab.*, 299, E647-56. ↗
- Belcher, SM., Zsarnovszky, A., Crawford, PA., Hemani, H., Spurling, L., Kirley, TL. (2006). Immunolocalization of ecto-nucleoside triphosphate diphosphohydrolase 3 in rat brain: implications for modulation of multiple homeostatic systems including feeding and sleep-wake behaviors. *Neuroscience*, 137, 1331-46. ↗

Editions

2015-12-30	Authored, Edited	Orlic-Milacic, M.
2016-05-11	Reviewed	Sévigny, J.

NTPDase3 hydrolyzes nucleoside diphosphates [↗](#)

Location: [Phosphate bond hydrolysis by NTPDase proteins](#)

Stable identifier: R-HSA-8851129

Type: transition

Compartments: extracellular region, plasma membrane

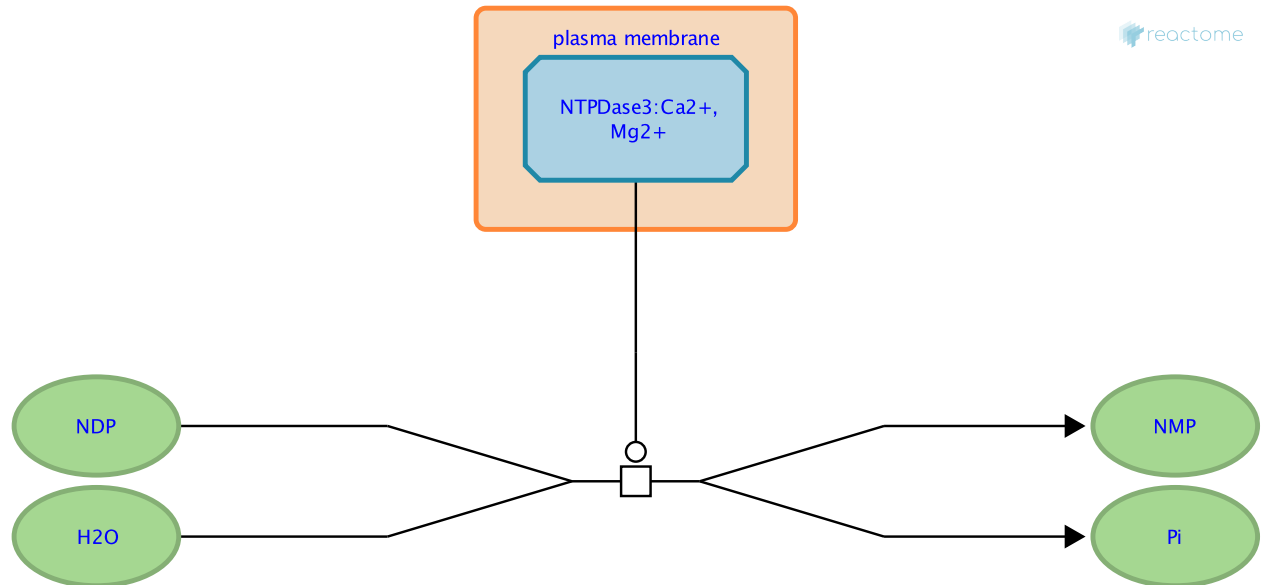

NTPDase3 (CD39L3), encoded by the ENTPD3 gene, is a plasma membrane-bound ectonucleotidase that hydrolyzes extracellular NDPs to corresponding NMPs (Smith and Kirley 1998, Lavoie et al. 2004, Vorhoff et al. 2005, Kukulski et al. 2005).

Preceded by: [NTPDase3 hydrolyzes nucleoside triphosphates](#)

Literature references

- Smith, TM., Kirley, TL. (1998). Cloning, sequencing, and expression of a human brain ecto-apyrase related to both the ecto-ATPases and CD39 ecto-apyrases1. *Biochim. Biophys. Acta*, 1386, 65-78. [↗](#)
- Kukulski, F., Lévesque, SA., Lavoie, EG., Lecka, J., Bigonnesse, F., Knowles, AF. et al. (2005). Comparative hydrolysis of P2 receptor agonists by NTPDases 1, 2, 3 and 8. *Purinergic Signal.*, 1, 193-204. [↗](#)
- Lavoie, EG., Kukulski, F., Lévesque, SA., Lecka, J., Sévigny, J. (2004). Cloning and characterization of mouse nucleoside triphosphate diphosphohydrolase-3. *Biochem. Pharmacol.*, 67, 1917-26. [↗](#)
- Vorhoff, T., Zimmermann, H., Pelletier, J., Sévigny, J., Braun, N. (2005). Cloning and characterization of the ectonucleotidase NTPDase3 from rat brain: Predicted secondary structure and relation to other members of the ENTPDase family and actin. *Purinergic Signal.*, 1, 259-70. [↗](#)

Editions

2015-12-30	Authored, Edited	Orlic-Milacic, M.
2016-05-11	Reviewed	Sévigny, J.

NTPDase4 hydrolyzes nucleoside triphosphates ↗

Location: [Phosphate bond hydrolysis by NTPDase proteins](#)

Stable identifier: R-HSA-8851234

Type: transition

Compartments: Golgi lumen, Golgi membrane

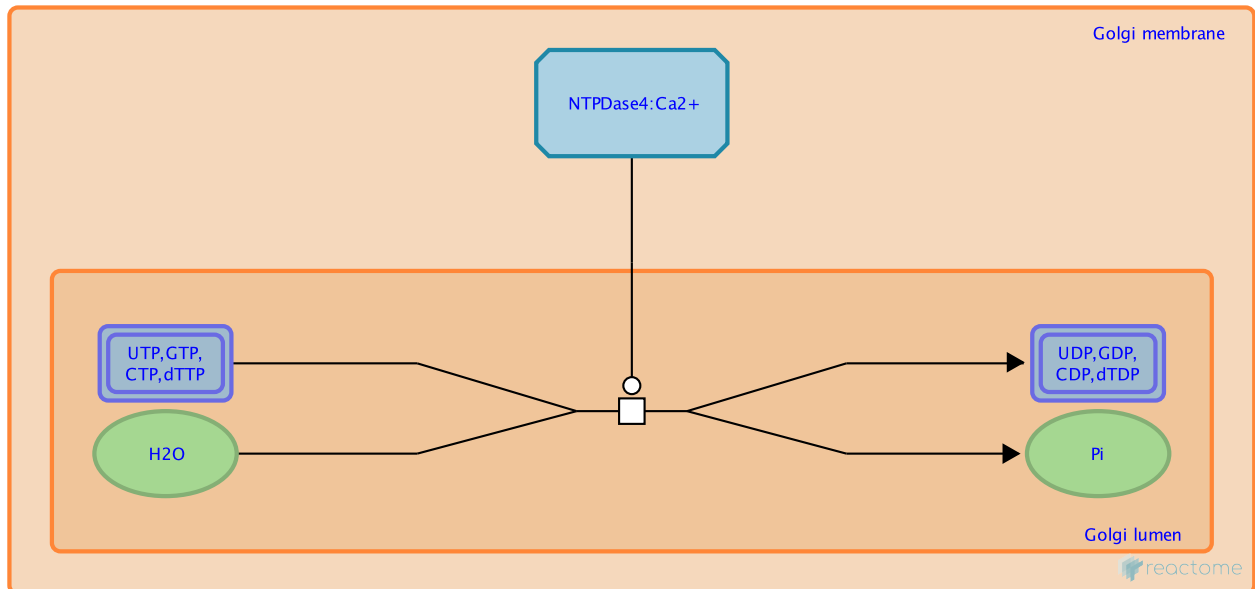

NTPDase4 (UDPase), encoded by the ENTPD4 gene, is an E-NTPDase family member that localizes to the Golgi membrane and can hydrolyze nucleoside triphosphates UTP, GTP, CTP and TTP to nucleoside diphosphates UDP, GDP, CDP and TDP, respectively, in the Golgi lumen. NTPDase4 hydrolyzes nucleoside triphosphates less efficiently than nucleoside diphosphates. Ca²⁺ is needed for NTPDase4 activity (Wang and Guidotti 1998).

Followed by: [NTPDase4 hydrolyzes nucleoside diphosphates](#)

Literature references

Wang, TF., Guidotti, G. (1998). Golgi localization and functional expression of human uridine diphosphatase. *J. Biol. Chem.*, 273, 11392-9. ↗

Editions

2015-12-30	Authored, Edited	Orlic-Milacic, M.
2016-05-11	Reviewed	Sévigny, J.

NTPDase4 hydrolyzes nucleoside diphosphates ↗

Location: [Phosphate bond hydrolysis by NTPDase proteins](#)

Stable identifier: R-HSA-8851225

Type: transition

Compartments: Golgi lumen, Golgi membrane

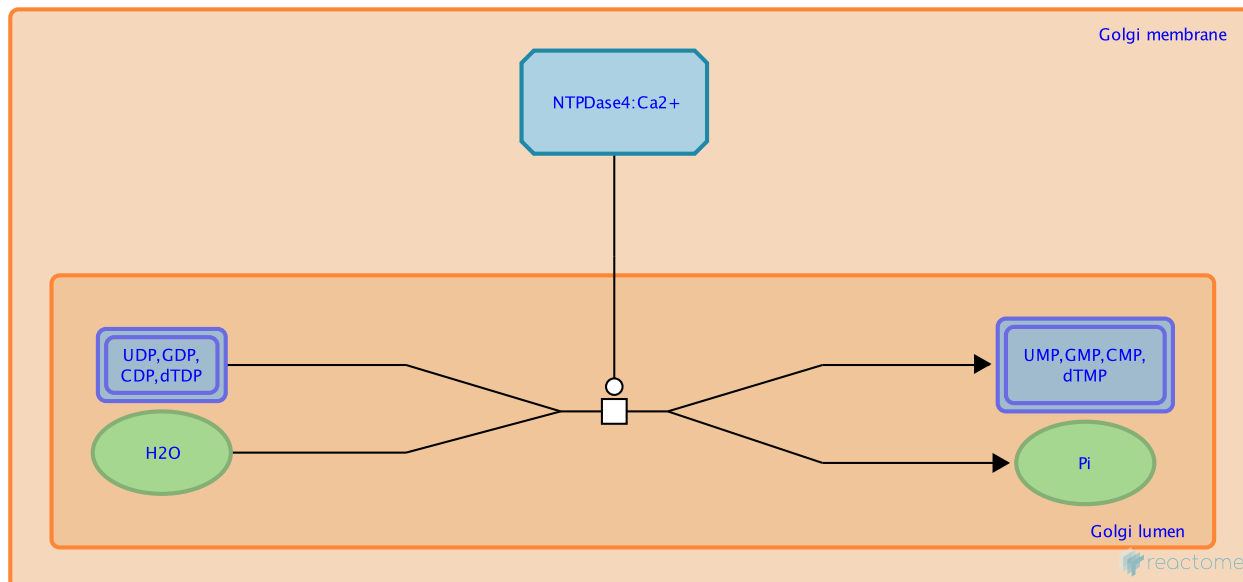

NTPDase4 (UDPase), encoded by the ENTPD4 gene, belongs to the E-NTPDase family of nucleotide phosphatases. NTPDase4 localizes to the Golgi membrane, with active site on the Golgi lumen side. In the presence of Ca^{2+} , NTPDase4 hydrolyzes nucleoside diphosphates UDP, GDP, CDP and dTDP to nucleoside monophosphates UMP, GMP, CMP and dTMP, respectively (Wang and Guidotti 1998).

Preceded by: [NTPDase4 hydrolyzes nucleoside triphosphates](#)

Literature references

Wang, TF., Guidotti, G. (1998). Golgi localization and functional expression of human uridine diphosphatase. *J. Biol. Chem.*, 273, 11392-9. ↗

Editions

2015-12-30	Authored, Edited	Orlic-Milacic, M.
2016-05-11	Reviewed	Sévigny, J.

NTPDase5 hydrolyzes nucleoside diphosphates ↗

Location: [Phosphate bond hydrolysis by NTPDase proteins](#)

Stable identifier: R-HSA-8851356

Type: transition

Compartments: extracellular region

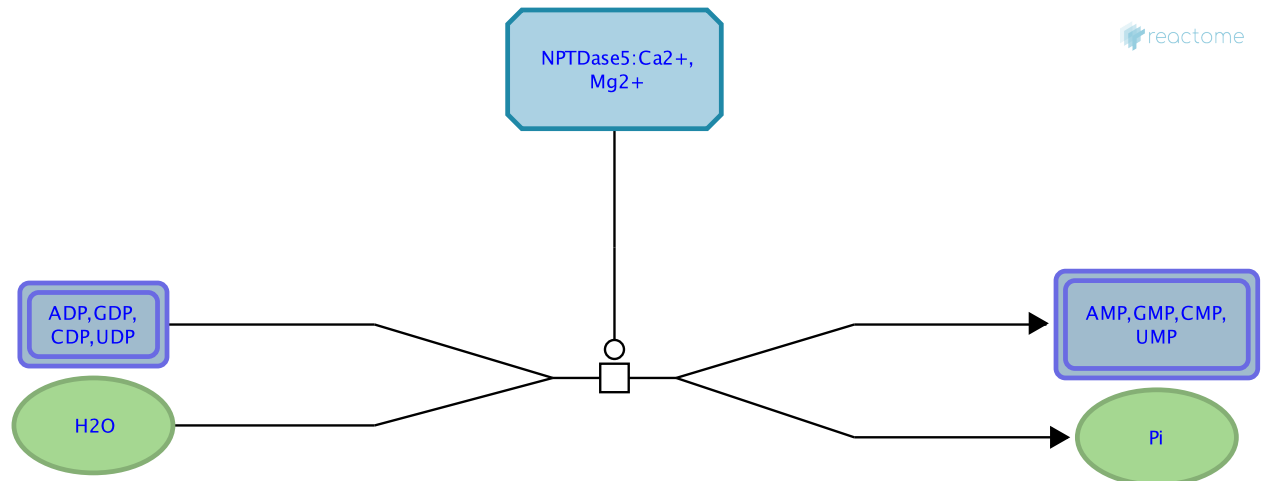

NTPDase5 (CD39L4), encoded by the ENTPD5 gene, is an E-NTPDase family member that is secreted to the extracellular space where it hydrolyzes nucleoside diphosphates UDP, GDP, CDP and ADP (listed in the order of preference) to nucleoside monophosphates UMP, GMP, CMP and AMP, respectively. In vitro, NTPDase5 can hydrolyze nucleoside triphosphates GTP, CTP, UTP and ATP to corresponding nucleoside diphosphates but with very low efficiency. NTPDase5 requires Ca²⁺ or Mg²⁺ for catalytic activity (Mulero et al. 1999). NTPDase5 is most catalytically active as a monomer, although it can also form disulfide-linked dimers (Mulero et al. 2000).

NTPDase5 may function in the endoplasmic reticulum (ER), where its UDPase activity could contribute to protein glycosylation and folding. NTPDase5 may alleviate ER stress induced by protein overload caused by oncogenic PI3K/AKT signaling in cancer cells. NTPDase5 is over-expressed in tumors with activated AKT and is known as the PCPH oncogene. The underlying mechanism of NTPDase5 over-expression may be AKT-mediated inhibition of FOXO proteins, which are probable transcriptional repressors of the ENTPD5 gene (Fang et al. 2010, Shen et al. 2011).

Preceded by: [NTPDase1 hydrolyzes nucleoside triphosphates](#)

Literature references

- Mulero, JJ., Yeung, G., Nelken, ST., Ford, JE. (1999). CD39-L4 is a secreted human apyrase, specific for the hydrolysis of nucleoside diphosphates. *J. Biol. Chem.*, 274, 20064-7. ↗
- Mulero, JJ., Yeung, G., Nelken, ST., Bright, JM., McGowan, DW., Ford, JE. (2000). Biochemical characterization of CD39L4. *Biochemistry*, 39, 12924-8. ↗
- Fang, M., Shen, Z., Huang, S., Zhao, L., Chen, S., Mak, TW. et al. (2010). The ER UDPase ENTPD5 promotes protein N-glycosylation, the Warburg effect, and proliferation in the PTEN pathway. *Cell*, 143, 711-24. ↗
- Shen, Z., Huang, S., Fang, M., Wang, X. (2011). ENTPD5, an endoplasmic reticulum UDPase, alleviates ER stress induced by protein overloading in AKT-activated cancer cells. *Cold Spring Harb. Symp. Quant. Biol.*, 76, 217-23. ↗

Editions

2015-12-30	Authored, Edited	Orlic-Milacic, M.
2016-05-11	Reviewed	Sévigny, J.

NTPDase6 hydrolyzes nucleoside diphosphates ↗

Location: [Phosphate bond hydrolysis by NTPDase proteins](#)

Stable identifier: R-HSA-8851396

Type: transition

Compartments: extracellular region

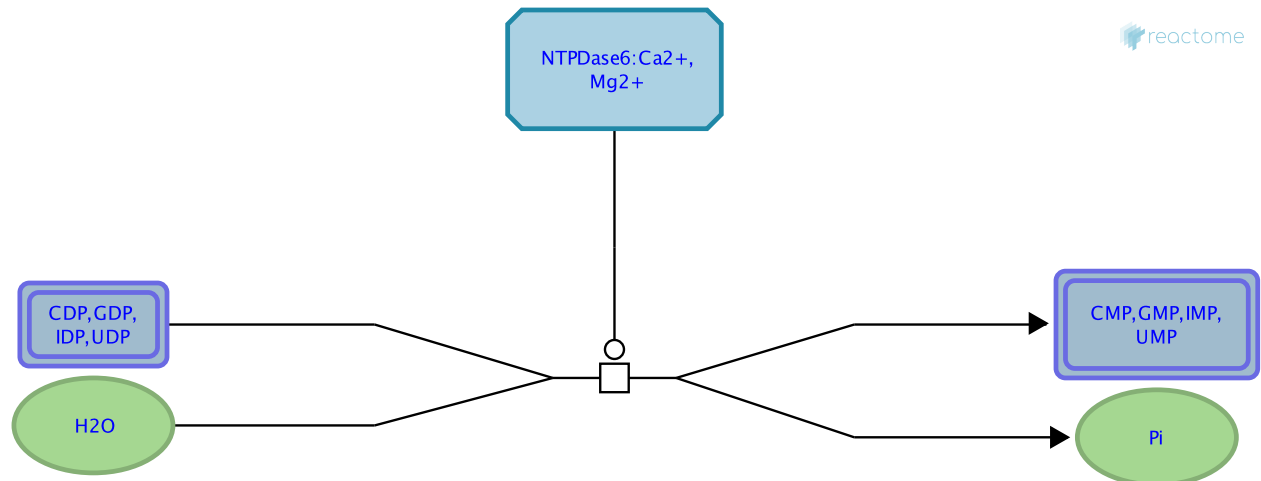

NTPDase6 (CD39L2), encoded by the ENTPD6 gene, is an ectonucleotide phosphatase of the E-NTPDase family that can be secreted (Yeung et al. 2000). Secretion involves the removal of the first 77 amino acids at the N-terminus by an unknown peptidase. Secreted NTPDase6 hydrolyzes nucleoside diphosphates GDP, IDP and, less efficiently, UDP and CDP to nucleoside monophosphates GMP, IMP, UMP and CMP, respectively. Secreted NTPDase6 hydrolyzes ADP to AMP and nucleoside triphosphates GTP, ITP, UTP and CTP to corresponding nucleoside diphosphates with very low efficacy (Hicks-Berger et al. 2000, Yeung et al. 2000, Ivanenkov et al. 2003). NTPDase6 requires Ca²⁺ or Mg²⁺ for catalytic activity (Hicks-Berger et al. 2000, Ivanenkov et al. 2003).

NTPDase6 may also be able to function as a membrane-bound enzyme, but its catalytic rate is very low and accounts for up to 10% of NTPDase6 activity (Hicks-Berger et al. 2000).

Literature references

Yeung, G., Mulero, JJ., McGowan, DW., Bajwa, SS., Ford, JE. (2000). CD39L2, a gene encoding a human nucleoside diphosphatase, predominantly expressed in the heart. *Biochemistry*, 39, 12916-23. ↗

Ivanenkov, VV., Murphy-Piedmonte, DM., Kirley, TL. (2003). Bacterial expression, characterization, and disulfide bond determination of soluble human NTPDase6 (CD39L2) nucleotidase: implications for structure and function. *Biochemistry*, 42, 11726-35. ↗

Hicks-Berger, CA., Chadwick, BP., Frischauf, AM., Kirley, TL. (2000). Expression and characterization of soluble and membrane-bound human nucleoside triphosphate diphosphohydrolase 6 (CD39L2). *J. Biol. Chem.*, 275, 34041-5. ↗

Editions

2015-12-30	Authored, Edited	Orlic-Milacic, M.
2016-05-11	Reviewed	Sévigny, J.

NTPDase7 hydrolyzes nucleoside triphosphates ↗

Location: Phosphate bond hydrolysis by NTPDase proteins

Stable identifier: R-HSA-8851494

Type: transition

Compartments: endocytic vesicle lumen, endocytic vesicle membrane

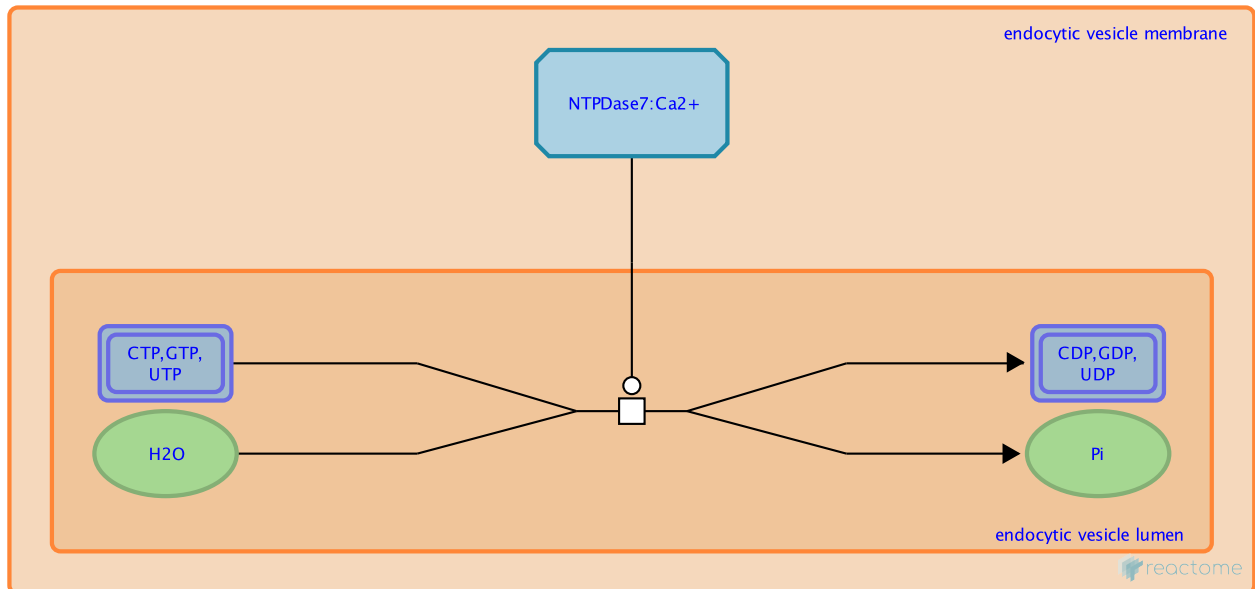

NTPDase7 (LALP1), encoded by the ENTPD7 gene, is a cytoplasmic vesicle membrane-bound nucleotide phosphatase that hydrolyzes nucleoside triphosphates CTP, GTP and UTP to nucleoside diphosphates CDP, GDP and UDP, respectively. NTPDase7 may have a low activity towards ATP and nucleoside diphosphates (Shi et al. 2001). NTPDase7 requires Ca²⁺ for catalytic activity (Shi et al. 2001). In mice, NTPDase7 was shown to regulate development of IL17-secreting Th17 cells in the small intestine, possibly by regulating extracellular ATP levels (Kusu et al. 2013).

Literature references

Shi, JD., Kukar, T., Wang, CY., Li, QZ., Cruz, PE., Davoodi-Semiromi, A. et al. (2001). Molecular cloning and characterization of a novel mammalian endo-apyrase (LALP1). *J. Biol. Chem.*, 276, 17474-8. ↗

Kusu, T., Kayama, H., Kinoshita, M., Jeon, SG., Ueda, Y., Goto, Y. et al. (2013). Ecto-nucleoside triphosphate diphosphohydrolase 7 controls Th17 cell responses through regulation of luminal ATP in the small intestine. *J. Immunol.*, 190, 774-83. ↗

Editions

2015-12-30	Authored, Edited	Orlic-Milacic, M.
2016-05-11	Reviewed	Sévigny, J.

NTPDase8 hydrolyzes nucleoside triphosphates ↗

Location: [Phosphate bond hydrolysis by NTPDase proteins](#)

Stable identifier: R-HSA-8851538

Type: transition

Compartments: extracellular region, plasma membrane

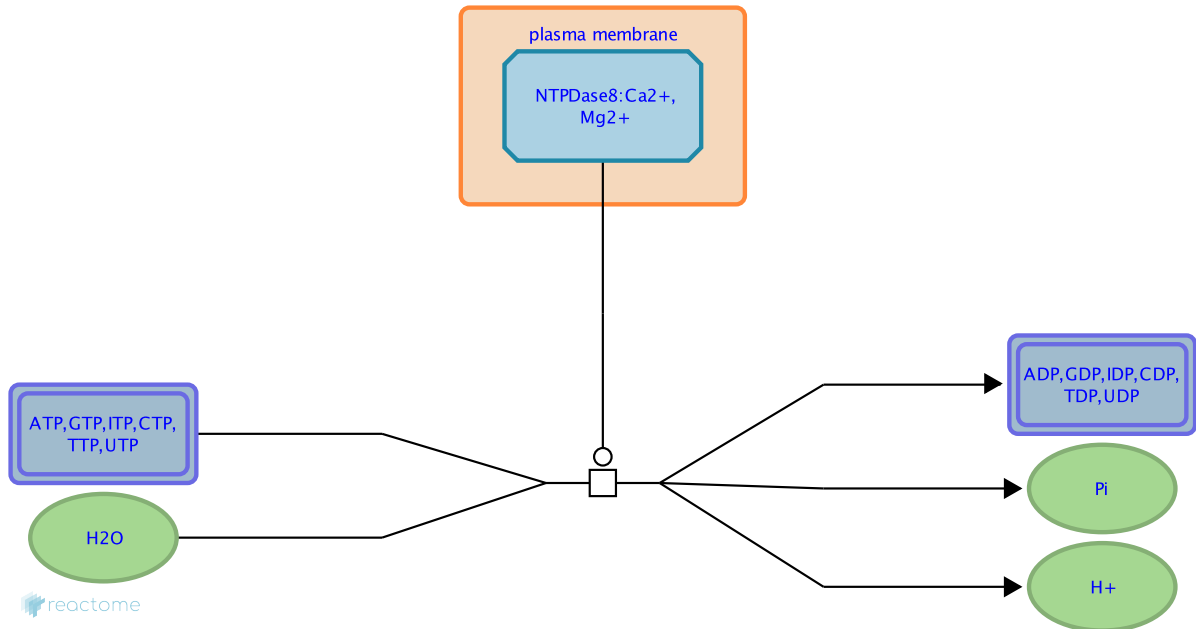

NTPDase8, encoded by the ENTPD8 gene, is an E-NTPDase family ectonucleotide phosphatase that, in the presence of Ca^{2+} or Mg^{2+} , hydrolyzes NTPs to NMPs, via corresponding NDP intermediates. NTPDase8 is more efficient in hydrolyzing NTPs than NDPs. NTPDase8 provides the main ectonucleotide phosphatase activity in rat and porcine livers (Sévigny et al. 2000, Fausther et al. 2007).

Followed by: [NTPDase8 hydrolyzes nucleoside diphosphates](#)

Literature references

Fausther, M., Lecka, J., Kukulski, F., Lévesque, SA., Pelletier, J., Zimmermann, H. et al. (2007). Cloning, purification, and identification of the liver canalicular ecto-ATPase as NTPDase8. *Am. J. Physiol. Gastrointest. Liver Physiol.*, 292, G785-95. ↗

Sévigny, J., Robson, SC., Waelkens, E., Csizmadia, E., Smith, RN., Lemmens, R. (2000). Identification and characterization of a novel hepatic canalicular ATP diphosphohydrolase. *J. Biol. Chem.*, 275, 5640-7. ↗

Editions

2015-12-30	Authored, Edited	Orlic-Milacic, M.
2016-05-11	Reviewed	Sévigny, J.

NTPDase8 hydrolyzes nucleoside diphosphates ↗

Location: [Phosphate bond hydrolysis by NTPDase proteins](#)

Stable identifier: R-HSA-8851550

Type: transition

Compartments: extracellular region, plasma membrane

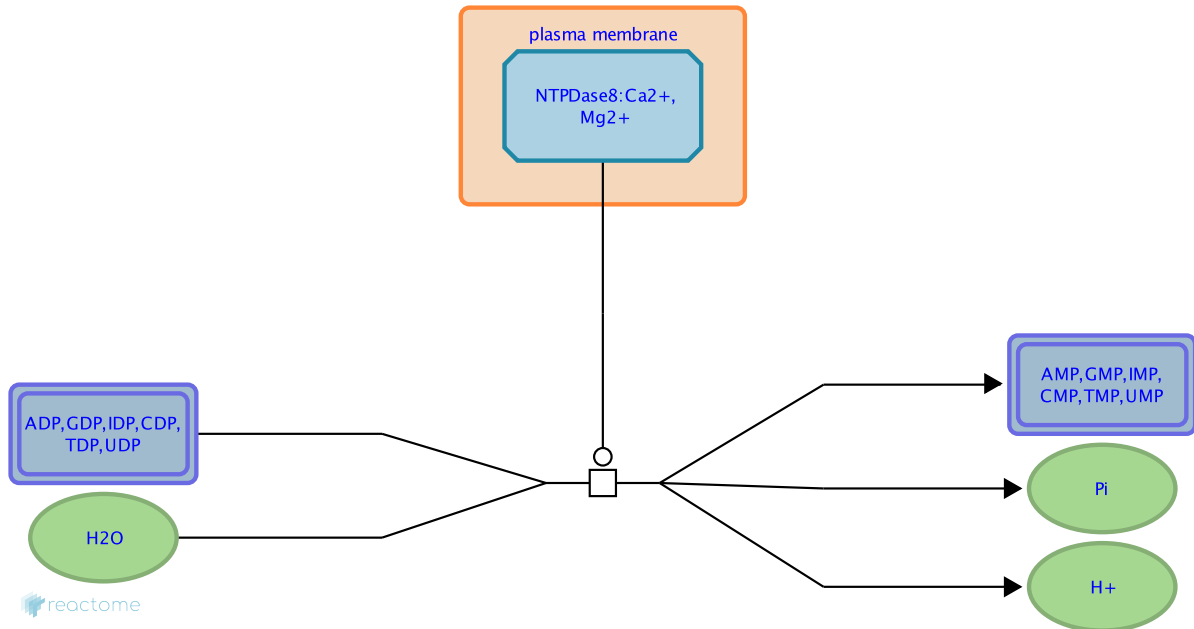

NTPDase8, encoded by the ENTPD8 gene, is the main liver ectonucleotide phosphatase. NTPDase8 belongs to the E-NTPDase family of nucleotide phosphatases and can hydrolyze NDPs to corresponding NMPs (Sévigny et al. 2000, Bigonnesse et al. 2004, Fausther et al. 2007).

Preceded by: [NTPDase8 hydrolyzes nucleoside triphosphates](#)

Literature references

Fausther, M., Lecka, J., Kukulski, F., Lévesque, SA., Pelletier, J., Zimmermann, H. et al. (2007). Cloning, purification, and identification of the liver canalicular ecto-ATPase as NTPDase8. *Am. J. Physiol. Gastrointest. Liver Physiol.*, 292, G785-95. ↗

Sévigny, J., Robson, SC., Waelkens, E., Csizmadia, E., Smith, RN., Lemmens, R. (2000). Identification and characterization of a novel hepatic canalicular ATP diphosphohydrolase. *J. Biol. Chem.*, 275, 5640-7. ↗

Bigonnesse, F., Lévesque, SA., Kukulski, F., Lecka, J., Robson, SC., Fernandes, MJ. et al. (2004). Cloning and characterization of mouse nucleoside triphosphate diphosphohydrolase-8. *Biochemistry*, 43, 5511-9. ↗

Editions

2015-12-30	Authored, Edited	Orlic-Milacic, M.
2016-05-11	Reviewed	Sévigny, J.

Table of Contents

Introduction	1
⚡ Phosphate bond hydrolysis by NTPDase proteins	2
↳ NTPDase1 hydrolyzes nucleoside triphosphates	4
↳ NTPDase1 hydrolyzes nucleoside diphosphates	6
↳ NTPDase2 hydrolyzes nucleoside triphosphates	7
↳ NTPDase3 hydrolyzes nucleoside triphosphates	9
↳ NTPDase3 hydrolyzes nucleoside diphosphates	10
↳ NTPDase4 hydrolyzes nucleoside triphosphates	11
↳ NTPDase4 hydrolyzes nucleoside diphosphates	12
↳ NTPDase5 hydrolyzes nucleoside diphosphates	13
↳ NTPDase6 hydrolyzes nucleoside diphosphates	15
↳ NTPDase7 hydrolyzes nucleoside triphosphates	16
↳ NTPDase8 hydrolyzes nucleoside triphosphates	17
↳ NTPDase8 hydrolyzes nucleoside diphosphates	18
Table of Contents	19