

Interleukin-4 and Interleukin-13 signaling

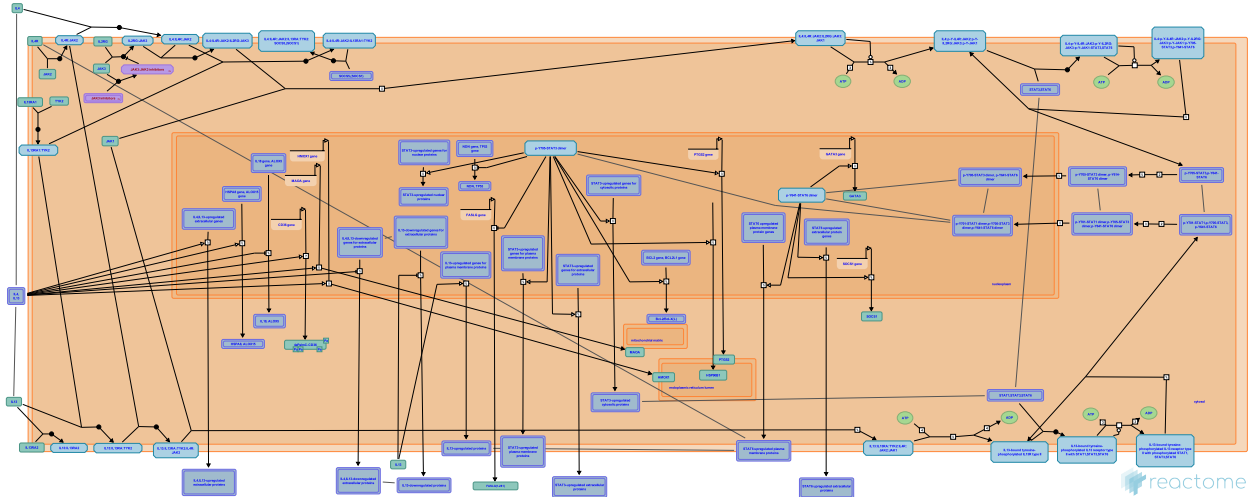

Jassal, B., Jupe, S., Leibovich, S.J., Limon, P.L., Meldal, B.H., Ray, K.P., Shoichet, B.K.

European Bioinformatics Institute, New York University Langone Medical Center, Ontario Institute for Cancer Research, Oregon Health and Science University.

The contents of this document may be freely copied and distributed in any media, provided the authors, plus the institutions, are credited, as stated under the terms of [Creative Commons Attribution 4.0 International \(CC BY 4.0\) License](https://creativecommons.org/licenses/by/4.0/). For more information see our [license](https://creativecommons.org/licenses/by/4.0/).

Introduction

Reactome is open-source, open access, manually curated and peer-reviewed pathway database. Pathway annotations are authored by expert biologists, in collaboration with Reactome editorial staff and cross-referenced to many bioinformatics databases. A system of evidence tracking ensures that all assertions are backed up by the primary literature. Reactome is used by clinicians, geneticists, genomics researchers, and molecular biologists to interpret the results of high-throughput experimental studies, by bioinformaticians seeking to develop novel algorithms for mining knowledge from genomic studies, and by systems biologists building predictive models of normal and disease variant pathways.

The development of Reactome is supported by grants from the US National Institutes of Health (P41 HG003751), University of Toronto (CFREF Medicine by Design), European Union (EU STRP, EMI-CD), and the European Molecular Biology Laboratory (EBI Industry program).

Literature references

- Fabregat, A., Sidiropoulos, K., Viteri, G., Forner, O., Marin-Garcia, P., Arnau, V. et al. (2017). Reactome pathway analysis: a high-performance in-memory approach. *BMC bioinformatics*, 18, 142. [↗](#)
- Sidiropoulos, K., Viteri, G., Sevilla, C., Jupe, S., Webber, M., Orlic-Milacic, M. et al. (2017). Reactome enhanced pathway visualization. *Bioinformatics*, 33, 3461-3467. [↗](#)
- Fabregat, A., Jupe, S., Matthews, L., Sidiropoulos, K., Gillespie, M., Garapati, P. et al. (2018). The Reactome Pathway Knowledgebase. *Nucleic Acids Res*, 46, D649-D655. [↗](#)
- Fabregat, A., Korninger, F., Viteri, G., Sidiropoulos, K., Marin-Garcia, P., Ping, P. et al. (2018). Reactome graph database: Efficient access to complex pathway data. *PLoS computational biology*, 14, e1005968. [↗](#)

Reactome database release: 77

This document contains 1 pathway and 47 reactions ([see Table of Contents](#))

Interleukin-4 and Interleukin-13 signaling ↗

Stable identifier: R-HSA-6785807

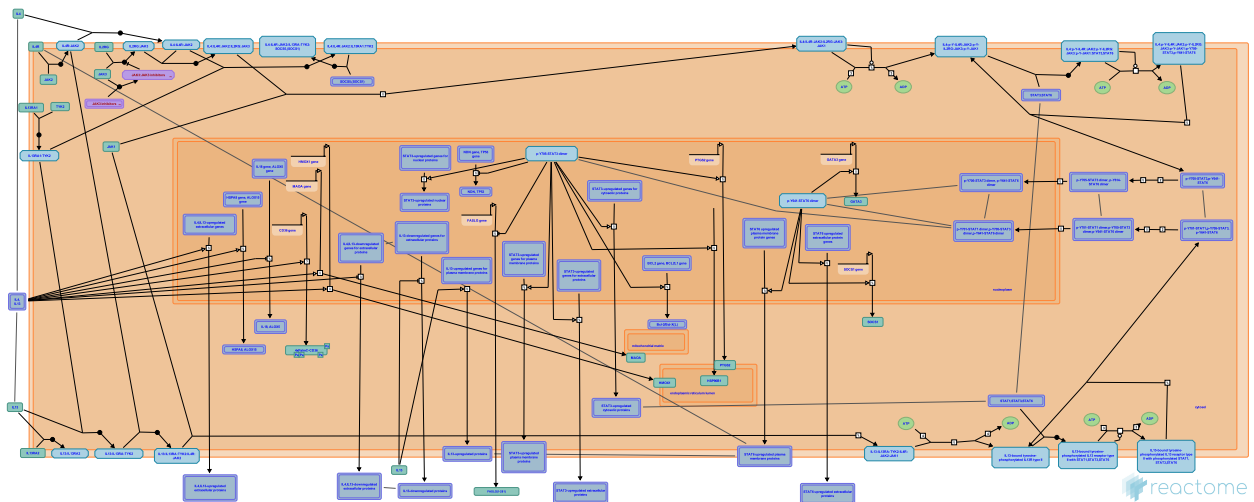

Interleukin-4 (IL4) is a principal regulatory cytokine during the immune response, crucially important in allergy and asthma (Nelms et al. 1999). When resting T cells are antigen-activated and expand in response to Interleukin-2 (IL2), they can differentiate as Type 1 (Th1) or Type 2 (Th2) T helper cells. The outcome is influenced by IL4. Th2 cells secrete IL4, which both stimulates Th2 in an autocrine fashion and acts as a potent B cell growth factor to promote humoral immunity (Nelms et al. 1999).

Interleukin-13 (IL13) is an immunoregulatory cytokine secreted predominantly by activated Th2 cells. It is a key mediator in the pathogenesis of allergic inflammation. IL13 shares many functional properties with IL4, stemming from the fact that they share a common receptor subunit. IL13 receptors are expressed on human B cells, basophils, eosinophils, mast cells, endothelial cells, fibroblasts, monocytes, macrophages, respiratory epithelial cells, and smooth muscle cells, but unlike IL4, not T cells. Thus IL13 does not appear to be important in the initial differentiation of CD4 T cells into Th2 cells, rather it is important in the effector phase of allergic inflammation (Hershey et al. 2003).

IL4 and IL13 induce “alternative activation” of macrophages, inducing an anti-inflammatory phenotype by signaling through IL4R alpha in a STAT6 dependent manner. This signaling plays an important role in the Th2 response, mediating anti-parasitic effects and aiding wound healing (Gordon & Martinez 2010, Loke et al. 2002)

There are two types of IL4 receptor complex (Andrews et al. 2006). Type I IL4R (IL4R1) is predominantly expressed on the surface of hematopoietic cells and consists of IL4R and IL2RG, the common gamma chain. Type II IL4R (IL4R2) is predominantly expressed on the surface of nonhematopoietic cells, it consists of IL4R and IL13RA1 and is also the type II receptor for IL13. (Obiri et al. 1995, Aman et al. 1996, Hilton et al. 1996, Miloux et al. 1997, Zhang et al. 1997). The second receptor for IL13 consists of IL4R and Interleukin-13 receptor alpha 2 (IL13RA2), sometimes called Interleukin-13 binding protein (IL13BP). It has a high affinity receptor for IL13 (Kd = 250 pmol/L) but is not sufficient to render cells responsive to IL13, even in the presence of IL4R (Donaldson et al. 1998). It is reported to exist in soluble form (Zhang et al. 1997) and when overexpressed reduces JAK-STAT signaling (Kawakami et al. 2001). Its function may be to prevent IL13 signalling via the functional IL4R:IL13RA1 receptor. IL13RA2 is overexpressed and enhances cell invasion in some human cancers (Joshi & Puri 2012).

The first step in the formation of IL4R1 (IL4:IL4R:IL2RB) is the binding of IL4 with IL4R (Hoffman et al. 1995, Shen et al. 1996, Hage et al. 1999). This is also the first step in formation of IL4R2 (IL4:IL4R:IL13RA1). After the initial binding of IL4 and IL4R, IL2RB binds (LaPorte et al. 2008), to form

IL4R1. Alternatively, IL13RA1 binds, forming IL4R2. In contrast, the type II IL13 complex (IL13R2) forms with IL13 first binding to IL13RA1 followed by recruitment of IL4R (Wang et al. 2009).

Crystal structures of the IL4:IL4R:IL2RG, IL4:IL4R:IL13RA1 and IL13:IL4R:IL13RA1 complexes have been determined (LaPorte et al. 2008). Consistent with these structures, in monocytes IL4R is tyrosine phosphorylated in response to both IL4 and IL13 (Roy et al. 2002, Gordon & Martinez 2010) while IL13RA1 phosphorylation is induced only by IL13 (Roy et al. 2002, LaPorte et al. 2008) and IL2RG phosphorylation is induced only by IL4 (Roy et al. 2002).

Both IL4 receptor complexes signal through Jak/STAT cascades. IL4R is constitutively-associated with JAK2 (Roy et al. 2002) and associates with JAK1 following binding of IL4 (Yin et al. 1994) or IL13 (Roy et al. 2002). IL2RG constitutively associates with JAK3 (Boussiotis et al. 1994, Russell et al. 1994). IL13RA1 constitutively associates with TYK2 (Umeshita-Suyama et al. 2000, Roy et al. 2002, LaPorte et al. 2008, Bhattacharjee et al. 2013).

IL4 binding to IL4R1 leads to phosphorylation of JAK1 (but not JAK2) and STAT6 activation (Takeda et al. 1994, Ratthe et al. 2007, Bhattacharjee et al. 2013).

IL13 binding increases activating tyrosine-99 phosphorylation of IL13RA1 but not that of IL2RG. IL4 binding to IL2RG leads to its tyrosine phosphorylation (Roy et al. 2002). IL13 binding to IL4R2 leads to TYK2 and JAK2 (but not JAK1) phosphorylation (Roy & Cathcart 1998, Roy et al. 2002).

Phosphorylated TYK2 binds and phosphorylates STAT6 and possibly STAT1 (Bhattacharjee et al. 2013).

A second mechanism of signal transduction activated by IL4 and IL13 leads to the insulin receptor substrate (IRS) family (Kelly-Welch et al. 2003). IL4R1 associates with insulin receptor substrate 2 and activates the PI3K/Akt and Ras/MEK/Erk pathways involved in cell proliferation, survival and translational control. IL4R2 does not associate with insulin receptor substrate 2 and consequently the PI3K/Akt and Ras/MEK/Erk pathways are not activated (Busch-Dienstfertig & González-Rodríguez 2013).

Literature references

Nelms, K., Keegan, AD., Zamorano, J., Ryan, JJ., Paul, WE. (1999). The IL-4 receptor: signaling mechanisms and biologic functions. *Annu. Rev. Immunol.*, 17, 701-38. ↗

Hershey, GK. (2003). IL-13 receptors and signaling pathways: an evolving web. *J. Allergy Clin. Immunol.*, 111, 677-90; quiz 691. ↗

Editions

2015-07-01	Authored	Jupe, S.
2016-09-02	Edited	Jupe, S.
2016-09-02	Reviewed	Leibovich, SJ.

IL4R binds JAK2 [↗](#)

Location: [Interleukin-4 and Interleukin-13 signaling](#)

Stable identifier: R-HSA-6785898

Type: binding

Compartments: cytosol, plasma membrane

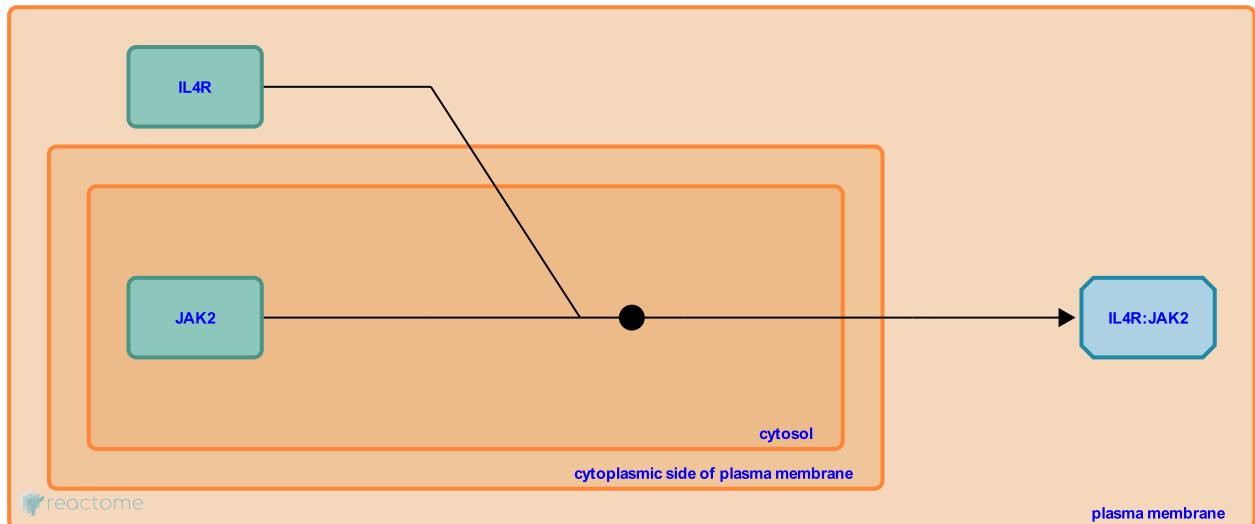

The interleukin-4 receptor (IL4R) constitutively binds Janus kinase 2 (JAK2) (Roy et al. 2002).

Followed by: [IL4 binds IL4R:JAK2](#), [IL13:IL13RA:TYK2 binds IL4R:JAK2](#)

Literature references

Roy, B., Bhattacharjee, A., Xu, B., Ford, D., Maizel, AL., Cathcart, MK. (2002). IL-13 signal transduction in human monocytes: phosphorylation of receptor components, association with Jaks, and phosphorylation/activation of Stats. *J. Leukoc. Biol.*, 72, 580-9. [↗](#)

Editions

2015-07-01	Authored	Jupe, S.
2016-09-02	Edited	Jupe, S.
2016-09-02	Reviewed	Leibovich, SJ.

IL2RG binds JAK3 ↗

Location: [Interleukin-4 and Interleukin-13 signaling](#)

Stable identifier: R-HSA-451895

Type: binding

Compartments: cytosol, plasma membrane

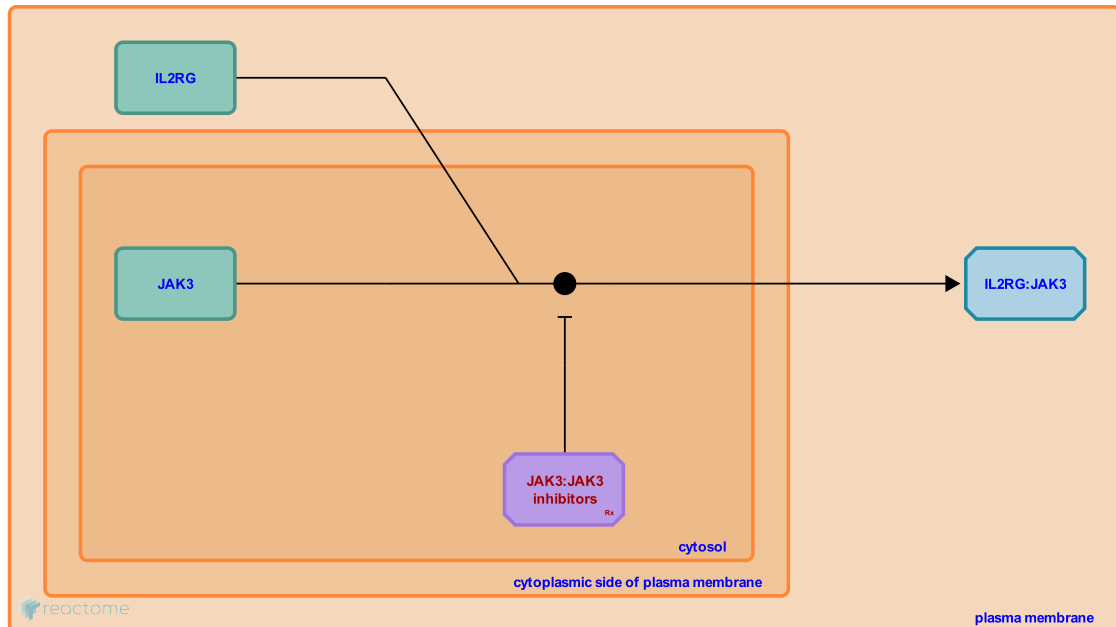

Cytokine receptor common gamma subunit (IL2RG, IL-2 receptor gamma chain, Gc) associates with Tyrosine-protein kinase JAK3 (JAK3). The carboxyl-terminal region of IL2RG is important for this association (Miyazaki et al. 1994, Zhu et al. 1998, Russel et al. 2004, Chen et al.1997, Nelson et al.1994) as well as the FERM domain in JAK3 (Zhou et al. 2001).

Followed by: [IL4:IL4R:JAK2 binds IL2RG:JAK3](#)

Literature references

Nelson, BH., Lord, JD., Greenberg, PD. (1994). Cytoplasmic domains of the interleukin-2 receptor beta and gamma chains mediate the signal for T-cell proliferation. *Nature*, 369, 333-6. ↗

Zhu, MH., Berry, JA., Russell, SM., Leonard, WJ. (1998). Delineation of the regions of interleukin-2 (IL-2) receptor beta chain important for association of Jak1 and Jak3. Jak1-independent functional recruitment of Jak3 to IL-2Rbeta. *J Biol Chem*, 273, 10719-25. ↗

Editions

2010-05-17	Authored	Ray, KP.
2010-08-06	Edited	Jupe, S.
2016-01-28	Reviewed	Meldal, BH.
2018-04-27	Edited	Jassal, B.
2018-04-27	Reviewed	Limon, PL.

JAK3 binds JAK3 inhibitors ↗

Location: [Interleukin-4 and Interleukin-13 signaling](#)

Stable identifier: R-HSA-9679028

Type: binding

Compartments: cytosol

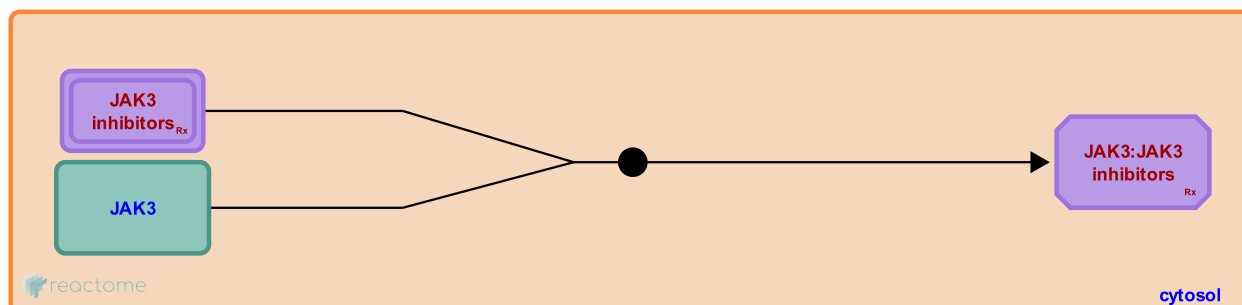

Janus Kinase 3 (JAK3) binds and is inhibited by several small molecule drugs (Clark et al. 2014, Changelian et al. 2003, Flanagan et al. 2010, Dhillon 2017, Chi et al. 2020). The Janus kinases (JAKs) are a family of intracellular tyrosine kinases that play an essential role in the signaling of numerous cytokines that have been implicated in the pathogenesis of inflammatory diseases. Drugs that inhibit these kinases such as baricitinib, tofacitinib, ruxolitinib and tofacitinib are thus plausible candidates for treatment of severe host inflammatory reactions to viral infection (Peterson et al. 2020, Richardson et al. 2020).

Literature references

Changelian, PS., Flanagan, ME., Ball, DJ., Kent, CR., Magnuson, KS., Martin, WH. et al. (2003). Prevention of organ allograft rejection by a specific Janus kinase 3 inhibitor. *Science*, 302, 875-8. ↗

Clark, JD., Flanagan, ME., Telliez, JB. (2014). Discovery and development of Janus kinase (JAK) inhibitors for inflammatory diseases. *J. Med. Chem.*, 57, 5023-38. ↗

Flanagan, ME., Blumenkopf, TA., Brissette, WH., Brown, MF., Casavant, JM., Shang-Poa, C. et al. (2010). Discovery of CP-690,550: a potent and selective Janus kinase (JAK) inhibitor for the treatment of autoimmune diseases and organ transplant rejection. *J. Med. Chem.*, 53, 8468-84. ↗

Dhillon, S. (2017). Tofacitinib: A Review in Rheumatoid Arthritis. *Drugs*, 77, 1987-2001. ↗

Chi, F., Chen, L., Wang, C., Li, L., Sun, X., Xu, Y. et al. (2020). JAK3 inhibitors based on thieno[3,2-d]pyrimidine scaffold: design, synthesis and bioactivity evaluation for the treatment of B-cell lymphoma. *Bioorg. Chem.*, 95, 103542. ↗

Editions

2020-03-23	Authored, Edited	Jassal, B.
2020-05-14	Reviewed	Shoichet, BK.

IL13RA1 binds TYK2 ↗

Location: [Interleukin-4 and Interleukin-13 signaling](#)

Stable identifier: R-HSA-6785762

Type: binding

Compartments: plasma membrane, cytosol

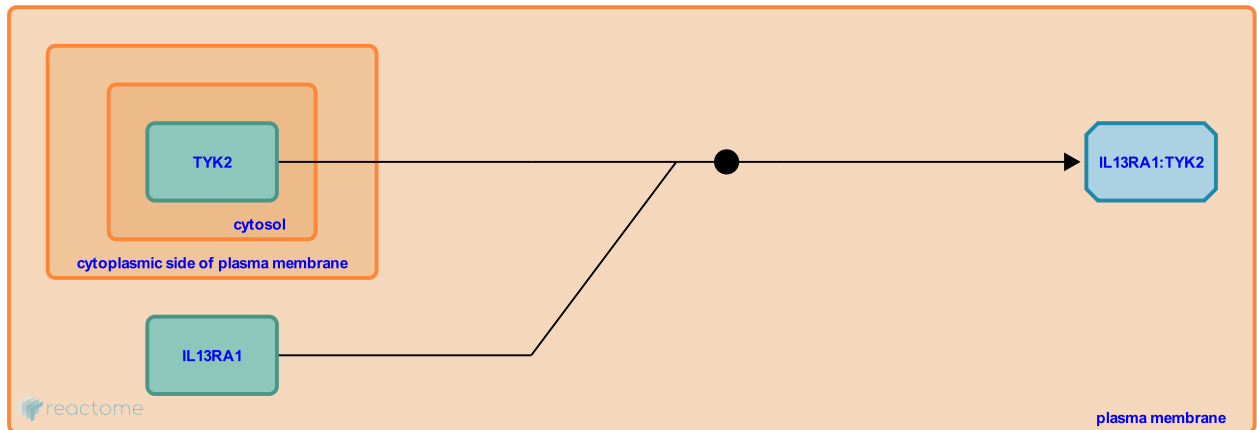

Interleukin-13 receptor subunit alpha-1 (IL13RA1) constitutively associates with Non-receptor tyrosine-protein kinase 2 (TYK2) (Umeshita-Suyama et al. 2000, Roy et al. 2002, LaPorte et al. 2008, Bhattacharjee et al. 2013).

Followed by: [IL4:IL4R:JAK2 binds IL13RA1:TYK2](#), [IL13 binds IL13RA:TYK2](#)

Literature references

Umeshita-Suyama, R., Sugimoto, R., Akaiwa, M., Arima, K., Yu, B., Wada, M. et al. (2000). Characterization of IL-4 and IL-13 signals dependent on the human IL-13 receptor alpha chain 1: redundancy of requirement of tyrosine residue for STAT3 activation. *Int. Immunol.*, 12, 1499-509. ↗

Bhattacharjee, A., Shukla, M., Yakubenko, VP., Mulya, A., Kundu, S., Cathcart, MK. (2013). IL-4 and IL-13 employ discrete signaling pathways for target gene expression in alternatively activated monocytes/macrophages. *Free Radic. Biol. Med.*, 54, 1-16. ↗

Editions

2015-07-01	Authored	Jupe, S.
2016-09-02	Edited	Jupe, S.
2016-09-02	Reviewed	Leibovich, SJ.

IL4 binds IL4R:JAK2 ↗

Location: [Interleukin-4 and Interleukin-13 signaling](#)

Stable identifier: R-HSA-6786101

Type: binding

Compartments: cytosol, extracellular region, plasma membrane

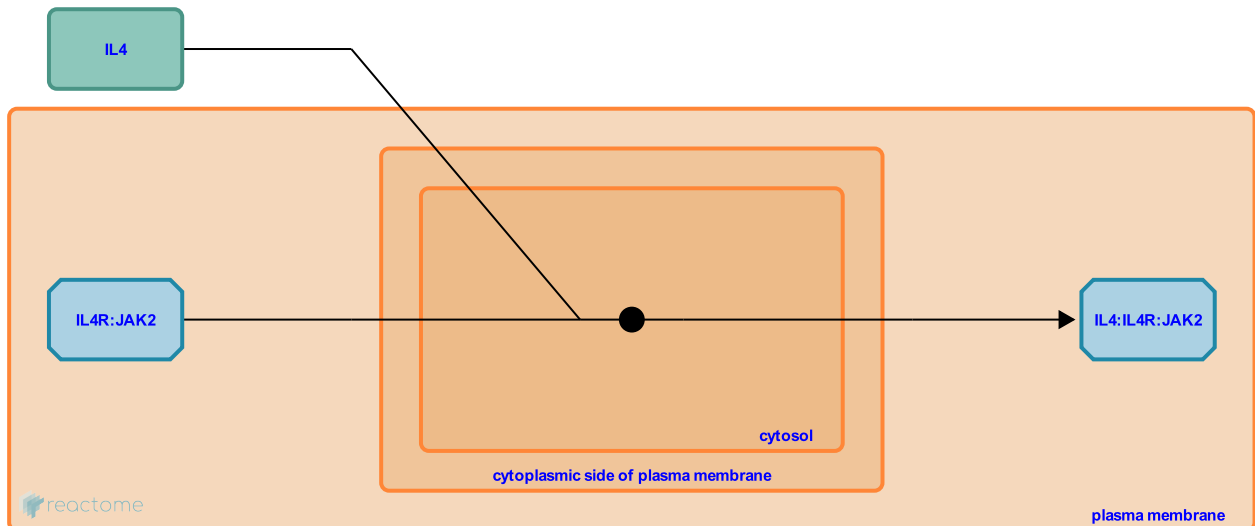

The first step in the formation of both types of IL4 receptor is the binding of Interleukin-4 (IL4) with Interleukin-4 receptor subunit alpha (IL4R), which has Janus kinase 2 (JAK2) constitutively associated (Hoffman et al. 1995, Shen et al. 1996, Hage et al. 1999).

Preceded by: [IL4R binds JAK2](#)

Followed by: [IL4:IL4R:JAK2 binds IL2RG:JAK3](#), [IL4:IL4R:JAK2 binds IL13RA1:TYK2](#)

Literature references

Hoffman, RC., Castner, BJ., Gerhart, M., Gibson, MG., Rasmussen, BD., March, CJ. et al. (1995). Direct evidence of a heterotrimeric complex of human interleukin-4 with its receptors. *Protein Sci.*, 4, 382-6. ↗

Shen, BJ., Hage, T., Sebald, W. (1996). Global and local determinants for the kinetics of interleukin-4/interleukin-4 receptor alpha chain interaction. A biosensor study employing recombinant interleukin-4-binding protein. *Eur. J. Biochem.*, 240, 252-61. ↗

Hage, T., Sebald, W., Reinemer, P. (1999). Crystal structure of the interleukin-4/receptor alpha chain complex reveals a mosaic binding interface. *Cell*, 97, 271-81. ↗

Editions

2015-07-01	Authored	Jupe, S.
2016-09-02	Edited	Jupe, S.
2016-09-02	Reviewed	Leibovich, SJ.

IL4:IL4R:JAK2 binds IL2RG:JAK3 ↗

Location: [Interleukin-4 and Interleukin-13 signaling](#)

Stable identifier: R-HSA-6786092

Type: binding

Compartments: plasma membrane, cytosol, extracellular region

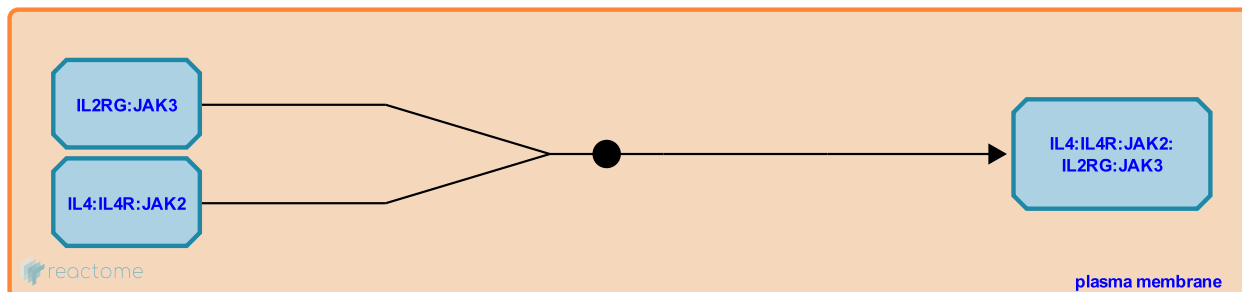

Interleukin 2 receptor gamma subunit (IL2RG), with constitutively-associated Janus kinase 3 (JAK3), binds the IL4:IL4R:JAK2 complex, interacting with IL4 and IL4R to form the ligand-bound type I IL4 receptor complex, IL4R1 (LaPorte et al. 2008).

Preceded by: [IL4 binds IL4R:JAK2](#), [IL2RG binds JAK3](#)

Followed by: [JAK1 binds IL4R in IL4-bound IL4R1](#)

Literature references

LaPorte, SL., Juo, ZS., Vaclavikova, J., Colf, LA., Qi, X., Heller, NM. et al. (2008). Molecular and structural basis of cytokine receptor pleiotropy in the interleukin-4/13 system. *Cell*, 132, 259-72. ↗

Editions

2015-07-01	Authored	Jupe, S.
2016-09-02	Edited	Jupe, S.
2016-09-02	Reviewed	Leibovich, SJ.

IL4:IL4R:JAK2 binds IL13RA1:TYK2 ↗

Location: [Interleukin-4 and Interleukin-13 signaling](#)

Stable identifier: R-HSA-6786070

Type: binding

Compartments: plasma membrane, cytosol, extracellular region

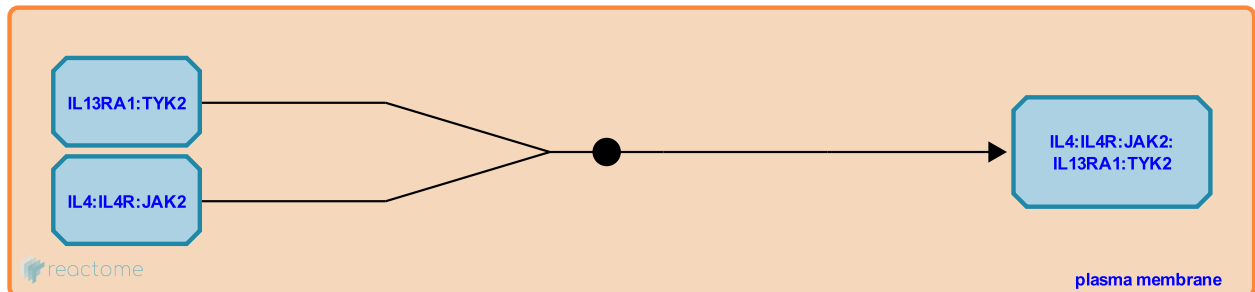

Interleukin-13 receptor subunit alpha-1 (IL13RA1), with associated Non-receptor tyrosine-protein kinase 2 (TYK2), binds the IL4:IL4R:JAK2 complex to form the ligand-bound Type II IL4 receptor complex (IL4R2). IL4R2 is predominantly expressed on the surface of non-hematopoietic cells. It is also a receptor for Interleukin-13 (IL13) (Obiri et al. 1995, Aman et al. 1996, Hilton et al. 1996). Crystal structures of the IL4:IL4R:IL13RA1 and IL13:IL4R:IL13RA1 complexes have been determined (LaPorte et al. 2008).

Preceded by: [IL13RA1 binds TYK2](#), [IL4 binds IL4R:JAK2](#)

Followed by: [SOCS5,\(SOCS1\) bind IL4RA](#)

Literature references

Laporte, SL., Juo, ZS., Vaclavikova, J., Colf, LA., Qi, X., Heller, NM. et al. (2008). Molecular and structural basis of cytokine receptor pleiotropy in the interleukin-4/13 system. *Cell*, 132, 259-72. ↗

Editions

2015-07-01	Authored	Jupe, S.
2016-09-02	Edited	Jupe, S.
2016-09-02	Reviewed	Leibovich, SJ.

JAK1 binds IL4R in IL4-bound IL4R1 ↗

Location: [Interleukin-4 and Interleukin-13 signaling](#)

Stable identifier: R-HSA-6786058

Type: omitted

Compartments: cytosol, extracellular region, plasma membrane

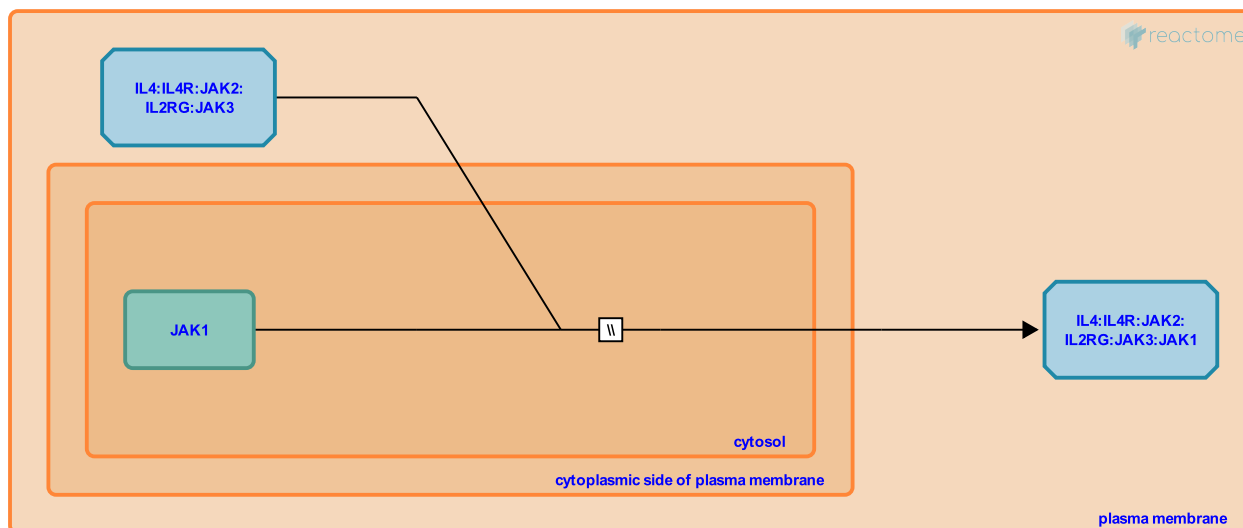

In human blood monocytes, where the type I interleukin-4 (IL4) receptor (IL4R1) is the predominant IL4 receptor type, IL4 leads to tyrosine phosphorylation of Janus kinase 1 (JAK1), rather than constitutively bound JAK2, JAK3 or Non-receptor associated tyrosine kinase 2 (TYK2). JAK1 was found to be essential for IL4-mediated expression of 15-lipoxygenase while JAK2 and TYK2 antisense inhibition had no effect (Bhattacharjee et al. 2013). As JAK1 binds IL4RA in response to IL13 binding (Roy et al. 2002), it is believed that IL4 similarly triggers binding of JAK1 to IL4 receptor complexes. The molecular trigger for JAK1 binding is not clear.

Preceded by: [IL4:IL4R:JAK2 binds IL2RG:JAK3](#)

Followed by: [IL4R, IL2RG, JAK1 in IL4-bound IL4R1:JAK1 are phosphorylated](#)

Literature references

Bhattacharjee, A., Shukla, M., Yakubenko, VP., Mulya, A., Kundu, S., Cathcart, MK. (2013). IL-4 and IL-13 employ discrete signaling pathways for target gene expression in alternatively activated monocytes/macrophages. *Free Radic. Biol. Med.*, 54, 1-16. ↗

Roy, B., Bhattacharjee, A., Xu, B., Ford, D., Maizel, AL., Cathcart, MK. (2002). IL-13 signal transduction in human monocytes: phosphorylation of receptor components, association with Jaks, and phosphorylation/activation of Stats. *J. Leukoc. Biol.*, 72, 580-9. ↗

Editions

2015-07-01	Authored	Jupe, S.
2016-09-02	Edited	Jupe, S.
2016-09-02	Reviewed	Leibovich, SJ.

IL4R, IL2RG, JAK1 in IL4-bound IL4R1:JAK1 are phosphorylated ↗

Location: [Interleukin-4 and Interleukin-13 signaling](#)

Stable identifier: R-HSA-6786096

Type: omitted

Compartments: plasma membrane

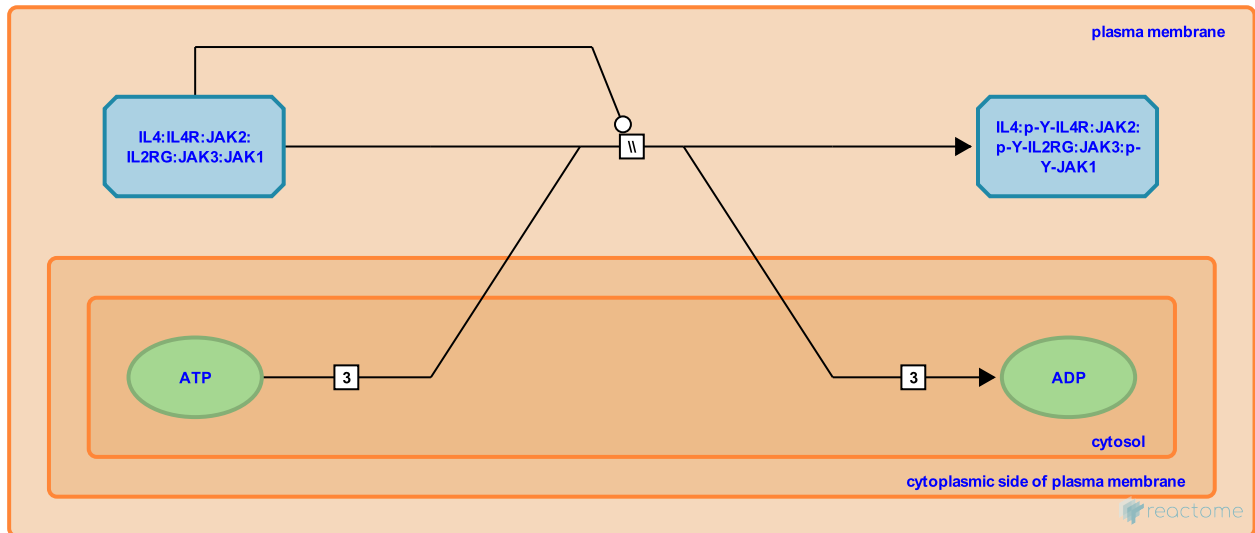

Interleukin-4 receptor subunit alpha (IL4R), Interleukin-2 receptor subunit gamma (IL2RG) and Janus kinase 1 (JAK1), but not Non-receptor associated tyrosine kinase 2 (TYK2), JAK2 or JAK3 are tyrosine phosphorylated in response to IL4 (Bhattacharjee et al. 2013). The order of these phosphorylation events is not clear. Based on studies of other interleukin receptors and their associated JAKs it is likely that JAK1 autophosphorylates and then phosphorylates IL4R and IL2RG.

IL4R contains 5 conserved tyrosine residues, Y497, Y575, Y603, Y631, and Y713, which can all play a role in signaling through this receptor. Structure-function analyses have revealed that Y497 is part of the IL4R motif that is necessary for the recruitment of IRS1 and IRS2 to IL4R and is critical for IL4-dependent cell proliferation (Keegan et al. 1994). STAT6 signaling requires one of tyrosines Y575, Y603, and Y631 (Ryan et al. 1996). Y713 is part of an immunotyrosine-based inhibitory motif (ITIM) shown to be important in the negative regulation of IL4 and IL13 responses (Kashiwada et al. 2001).

Preceded by: [JAK1 binds IL4R in IL4-bound IL4R1](#)

Followed by: [STAT3,STAT6 bind p-Y-IL4R](#)

Literature references

Bhattacharjee, A., Shukla, M., Yakubenko, VP., Mulya, A., Kundu, S., Cathcart, MK. (2013). IL-4 and IL-13 employ discrete signaling pathways for target gene expression in alternatively activated monocytes/macrophages. *Free Radic. Biol. Med.*, 54, 1-16. ↗

Editions

2015-07-01	Authored	Jupe, S.
2016-09-02	Edited	Jupe, S.
2016-09-02	Reviewed	Leibovich, SJ.

STAT3,STAT6 bind p-Y-IL4R ↗

Location: [Interleukin-4 and Interleukin-13 signaling](#)

Stable identifier: R-HSA-6786124

Type: binding

Compartments: cytosol, extracellular region, plasma membrane

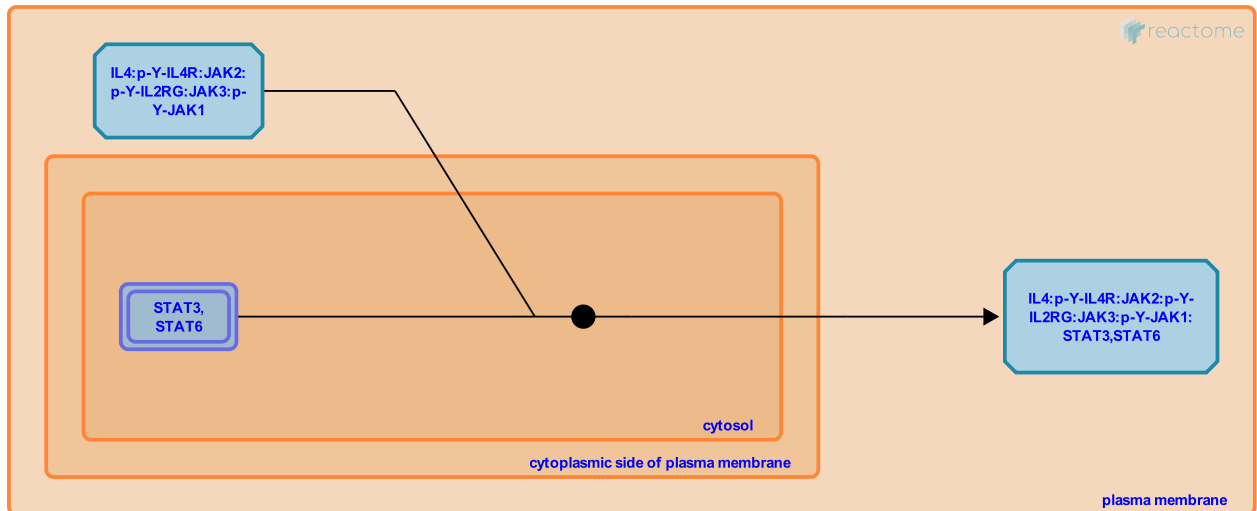

Signal transducer and activator of transcription 6 (STAT6) binds to tyrosine-phosphorylated Interleukin-4 receptor subunit alpha (IL4R) (Hou et al. 1994, Schindler et al. 1996, Mikita et al. 1998). Binding of STAT3 has also been reported (Rahaman et al. 2005, Bhattacharjee et al. 2013) but is sometimes reported to be dependent on interleukin-13 receptor subunit alpha (IL13RA) rather than IL4R (Umeshita-Suyama et al. 2000). Other reports have suggested that STAT3 is not phosphorylated in response to IL4 (Friedrich et al. 1999). Consistent with the fact that IL4 and IL13 receptors both incorporate IL4R, they also share common signaling pathways. IL4R is believed to be the signaling component of both IL4 and IL13 receptors because treatment with either generates intermediates that are characteristic of IL4 responses, including phosphorylation of IL4R, insulin receptor substrate 2 (IRS2), Janus kinase 1 (JAK1), and Non-receptor tyrosine-protein kinase 2 (TYK2) (Welham et al. 1995). STAT6-deficient mice suggest that IL13 signaling, like IL4 signaling, uses STAT6 (Takeda et al. 1996, Kaplan et al. 1996). STAT1 activation in response to IL4 has been reported (Wang et al. 2004) but also disputed (Bhattacharjee et al. 2013).

Preceded by: [IL4R, IL2RG, JAK1 in IL4-bound IL4R1:JAK1 are phosphorylated](#)

Followed by: [JAK1 phosphorylates STAT3,STAT6](#)

Literature references

- Hou, J., Schindler, U., Henzel, WJ., Ho, TC., Brasseur, M., McKnight, SL. (1994). An interleukin-4-induced transcription factor: IL-4 Stat. *Science*, 265, 1701-6. ↗
- Schindler, U., Wu, P., Rothe, M., Brasseur, M., McKnight, SL. (1995). Components of a Stat recognition code: evidence for two layers of molecular selectivity. *Immunity*, 2, 689-97. ↗
- Mikita, T., Daniel, C., Wu, P., Schindler, U. (1998). Mutational analysis of the STAT6 SH2 domain. *J. Biol. Chem.*, 273, 17634-42. ↗
- Rahaman, SO., Vogelbaum, MA., Haque, SJ. (2005). Aberrant Stat3 signaling by interleukin-4 in malignant glioma cells: involvement of IL-13Ralpha2. *Cancer Res.*, 65, 2956-63. ↗

Bhattacharjee, A., Shukla, M., Yakubenko, VP., Mulya, A., Kundu, S., Cathcart, MK. (2013). IL-4 and IL-13 employ discrete signaling pathways for target gene expression in alternatively activated monocytes/macrophages. *Free Radic. Biol. Med.*, 54, 1-16. [↗](#)

Editions

2015-07-01	Authored	Jupe, S.
2016-09-02	Edited	Jupe, S.
2016-09-02	Reviewed	Leibovich, SJ.

JAK1 phosphorylates STAT3,STAT6 ↗

Location: [Interleukin-4 and Interleukin-13 signaling](#)

Stable identifier: R-HSA-6786095

Type: transition

Compartments: cytosol, extracellular region, plasma membrane

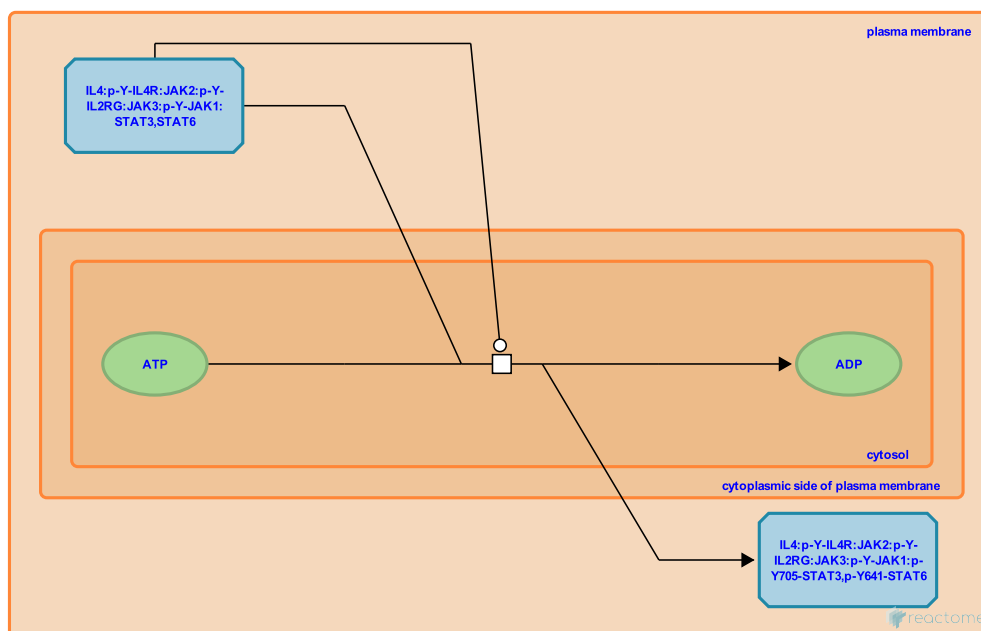

Signal transducer and activator of transcription 3 (STAT3) and STAT6 are phosphorylated by Janus kinase 1 (JAK1) in response to Interleukin-4 (IL4) (Bhattacharjee et al. 2013). STAT3 is phosphorylated on Y705, STAT6 is phosphorylated on Y641, residues critical for their function (Schindler & Darnell 1995, Mikita et al. 1996).

Preceded by: [STAT3,STAT6 bind p-Y-IL4R](#)

Followed by: [p-Y705-STAT3,p-Y641-STAT6 dissociate](#)

Literature references

Bhattacharjee, A., Shukla, M., Yakubenko, VP., Mulya, A., Kundu, S., Cathcart, MK. (2013). IL-4 and IL-13 employ discrete signaling pathways for target gene expression in alternatively activated monocytes/macrophages. *Free Radic. Biol. Med.*, 54, 1-16. ↗

Editions

2015-07-01	Authored	Jupe, S.
2016-09-02	Edited	Jupe, S.
2016-09-02	Reviewed	Leibovich, SJ.

p-Y705-STAT3,p-Y641-STAT6 dissociate ↗

Location: [Interleukin-4 and Interleukin-13 signaling](#)

Stable identifier: R-HSA-6786072

Type: omitted

Compartments: cytosol, extracellular region, plasma membrane

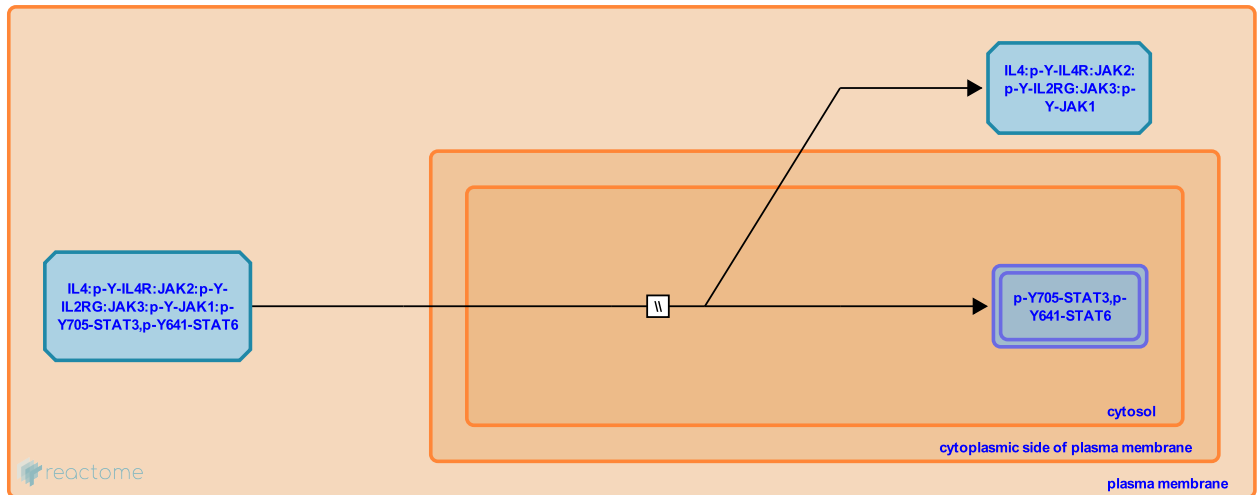

Once phosphorylated, Signal transducer and activator of transcription 3 (STAT3) and STAT6 dissociate from the IL4 receptor/JAK1 complex.

Preceded by: [JAK1 phosphorylates STAT3,STAT6](#)

Followed by: [p-Y705-STAT3, p-Y641-STAT6 dimerise](#)

Literature references

Bhattacharjee, A., Shukla, M., Yakubenko, VP., Mulya, A., Kundu, S., Cathcart, MK. (2013). IL-4 and IL-13 employ discrete signaling pathways for target gene expression in alternatively activated monocytes/macrophages. *Free Radic. Biol. Med.*, 54, 1-16. ↗

Editions

2015-07-01	Authored	Jupe, S.
2016-09-02	Edited	Jupe, S.
2016-09-02	Reviewed	Leibovich, SJ.

p-Y705-STAT3, p-Y641-STAT6 dimerise ↗

Location: [Interleukin-4 and Interleukin-13 signaling](#)

Stable identifier: R-HSA-6786097

Type: omitted

Compartments: cytosol

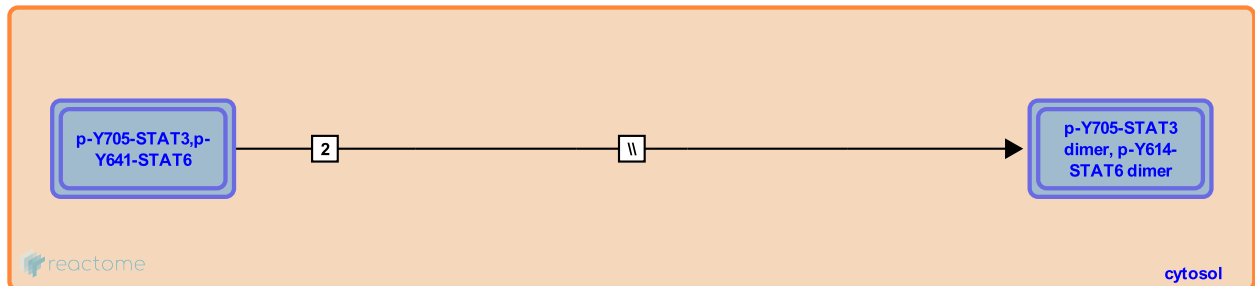

According to the classical model, phosphorylated Signal transducer and activator of transcription (STAT) monomers associate in an active dimer form, which is stabilized by the reciprocal interactions between a phosphorylated tyrosine residue of one and the SH2 domain of the other (Shuai et al. 1994, Mikita et al. 1996). These dimers then translocate to the nucleus (Akira et al. 1994). Recently an increasing number of studies have demonstrated the existence of STAT dimers in unstimulated cell states, and the capability of STATs to exert biological functions independently of phosphorylation (Braunstein et al. 2003, Li et al. 2008, Santos & Costas-Pereira 2011). As phosphorylation of STATs is not unequivocally required for its subsequent translocation to the nucleus, this event is shown as an uncertain process.

Preceded by: [p-Y705-STAT3, p-Y641-STAT6 dissociate](#)

Followed by: [p-Y705-STAT3 dimer, p-Y641-STAT6 dimer translocate to nucleus](#)

Literature references

Mikita, T., Campbell, D., Wu, P., Williamson, K., Schindler, U. (1996). Requirements for interleukin-4-induced gene expression and functional characterization of Stat6. *Mol. Cell. Biol.*, 16, 5811-20. ↗

Editions

2015-07-01	Authored	Jupe, S.
2016-09-02	Edited	Jupe, S.
2016-09-02	Reviewed	Leibovich, SJ.

p-Y705-STAT3 dimer, p-Y641-STAT6 dimer translocate to nucleus ↗

Location: [Interleukin-4 and Interleukin-13 signaling](#)

Stable identifier: R-HSA-6786293

Type: omitted

Compartments: cytosol, nucleoplasm

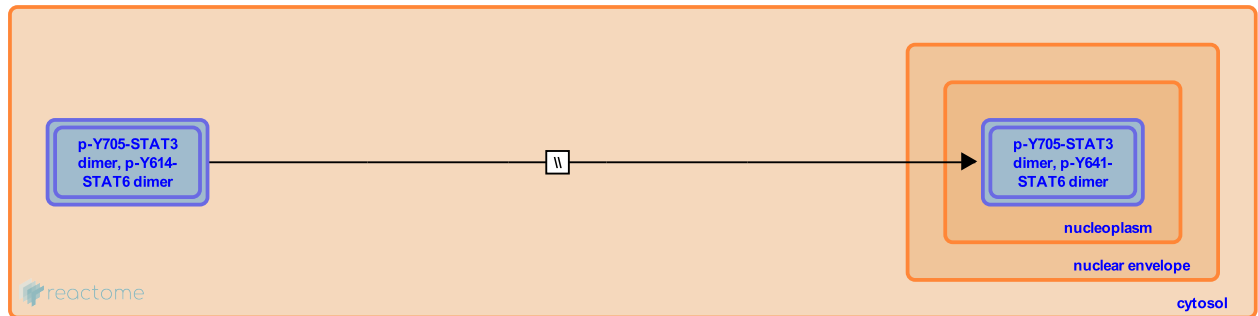

Phosphorylated, dimerized Signal transducer and activator of transcription 6 (STAT6) translocates to the nucleus where it regulates the expression of multiple genes (Mikita et al. 1996, Daines et al. 2003, Hebenstreit et al. 2006, Goenka & Kaplan 2011).

Preceded by: [p-Y705-STAT3, p-Y641-STAT6 dimerise](#)

Followed by: [Expression of STAT3-upregulated cytosolic proteins](#), [Expression of STAT3-upregulated nuclear proteins](#), [Expression of HSP90B1](#), [Expression of NDN,TP53](#), [Expression of SOCS1](#), [Expression of STAT3-upregulated plasma membrane proteins](#), [Expression of STAT6-upregulated extracellular proteins](#), [Expression of FASLG](#), [Expression of GATA3](#), [Expression of STAT3-upregulated extracellular proteins](#), [Expression of STAT6-upregulated plasma membrane proteins](#), [Expression of PTGS2](#), [Expression of BCL2, BCL2L1](#)

Literature references

Mikita, T., Campbell, D., Wu, P., Williamson, K., Schindler, U. (1996). Requirements for interleukin-4-induced gene expression and functional characterization of Stat6. *Mol. Cell. Biol.*, 16, 5811-20. ↗

Editions

2015-07-01	Authored	Jupe, S.
2016-09-02	Edited	Jupe, S.
2016-09-02	Reviewed	Leibovich, SJ.

Expression of SOCS1 [↗](#)

Location: [Interleukin-4 and Interleukin-13 signaling](#)

Stable identifier: R-HSA-6785860

Type: omitted

Compartments: cytosol, nucleoplasm

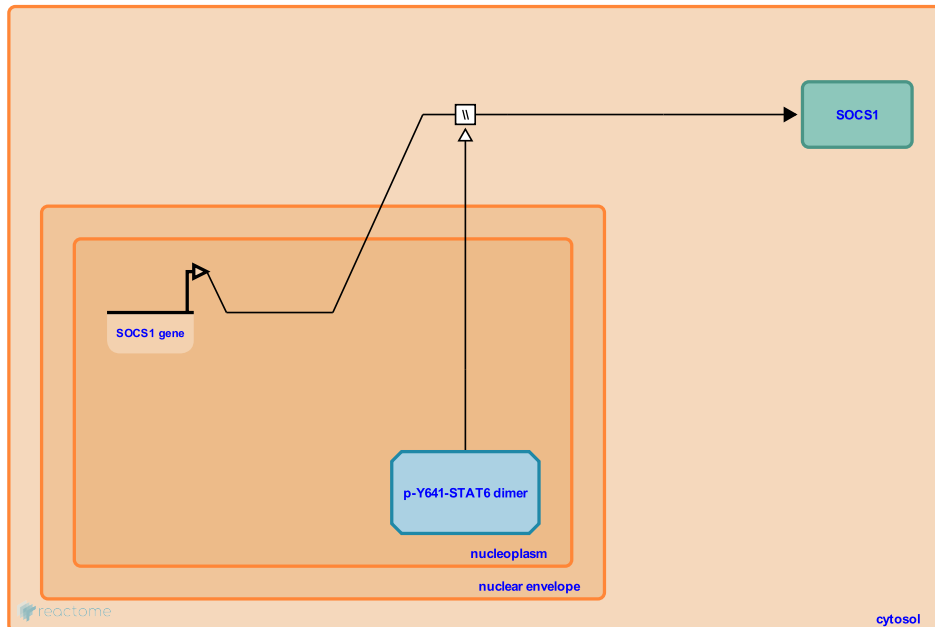

Phosphorylated Signal transducer and activator of transcription 6 (STAT6) dimers translocate to the nucleus and activate the transcription of several genes. In experimental models, targeted gene disruption of STAT6 inhibited airway hyper-responsiveness, airway inflammation, and fibrosis (Blease et al. 2002). STAT6 promotes transcription of the cytoplasmic protein Suppressor of cytokine signaling 1 (SOCS1) (Hebenstreit et al. 2003).

Preceded by: [p-Y705-STAT3 dimer](#), [p-Y641-STAT6 dimer translocate to nucleus](#)

Followed by: [SOCS5,\(SOCS1\) bind IL4RA](#)

Literature references

Hebenstreit, D., Wirnsberger, G., Horejs-Hoeck, J., Duschl, A. (2006). Signaling mechanisms, interaction partners, and target genes of STAT6. *Cytokine Growth Factor Rev.*, 17, 173-88. [↗](#)

Editions

2015-07-01	Authored	Jupe, S.
2016-09-02	Edited	Jupe, S.
2016-09-02	Reviewed	Leibovich, SJ.

Expression of GATA3 ↗

Location: [Interleukin-4 and Interleukin-13 signaling](#)

Stable identifier: R-HSA-6793975

Type: omitted

Compartments: nucleoplasm

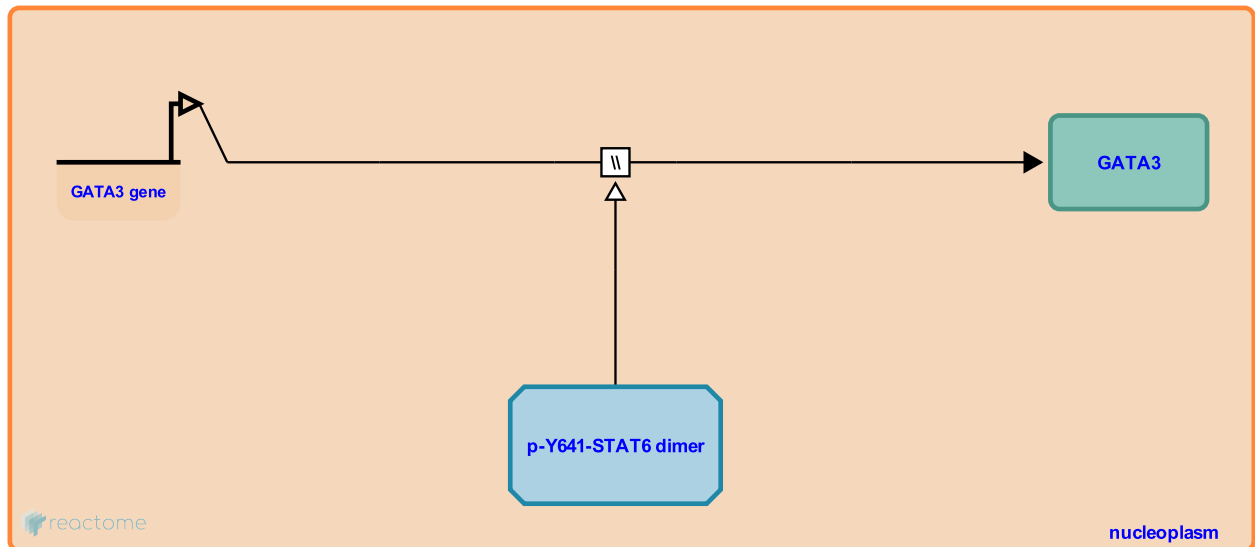

Phosphorylated Signal transducer and activator of transcription 6 (STAT6) dimers translocate to the nucleus and activate the transcription of several genes including the nuclear protein Trans-acting T-cell-specific transcription factor GATA-3 (Takeda et al. 1994, Park et al. 1998).

Preceded by: [p-Y705-STAT3 dimer](#), [p-Y641-STAT6 dimer translocate to nucleus](#)

Literature references

Takeda, K., Tanaka, T., Shi, W., Matsumoto, M., Minami, M., Kashiwamura, S. et al. (1996). Essential role of Stat6 in IL-4 signalling. *Nature*, 380, 627-30. ↗

Park, HJ., So, EY., Lee, CE. (1998). Interferon-gamma-induced factor binding to the interleukin-4-responsive element of CD23b promoter in human tonsillar mononuclear cells: role in transient up-regulation of the interleukin-4-induced CD23b mRNA. *Mol. Immunol.*, 35, 239-47. ↗

Editions

2015-07-01	Authored	Jupe, S.
2016-09-02	Edited	Jupe, S.
2016-09-02	Reviewed	Leibovich, SJ.

Expression of STAT6-upregulated extracellular proteins ↗

Location: [Interleukin-4 and Interleukin-13 signaling](#)

Stable identifier: R-HSA-6793978

Type: omitted

Compartments: extracellular region, nucleoplasm

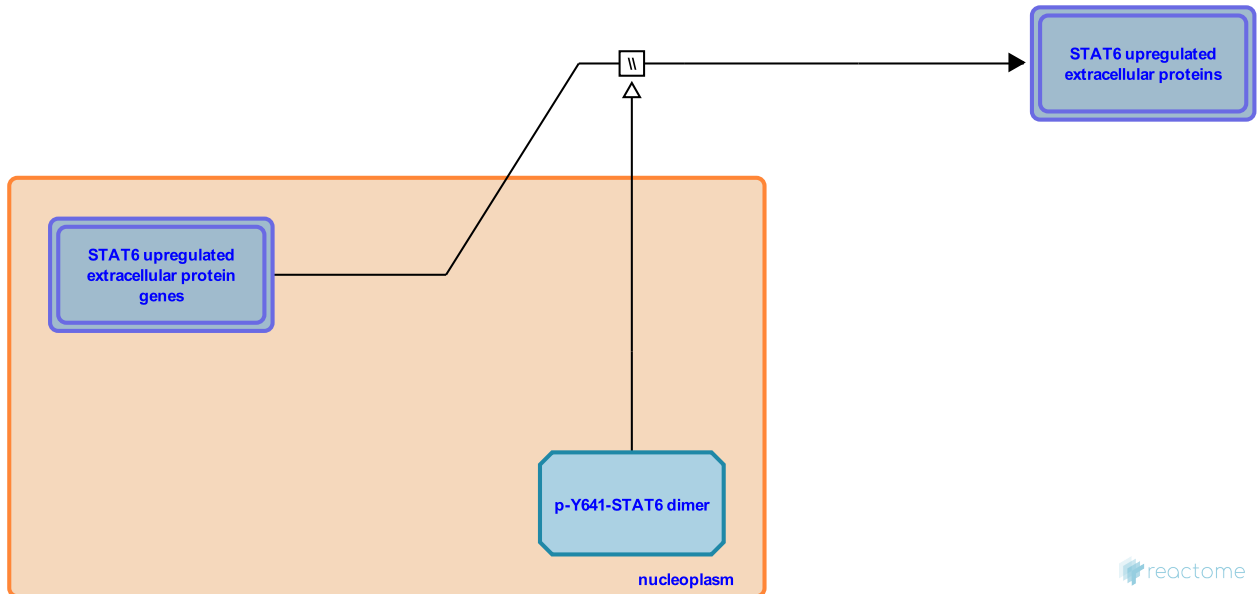

Phosphorylated Signal transducer and activator of transcription 6 (STAT6) dimers translocate to the nucleus and activate the transcription of several genes. In experimental models, targeted gene disruption of STAT6 inhibited airway hyperresponsiveness, airway inflammation, and fibrosis (Blease et al. 2002). STAT6 promotes transcription of the extracellular proteins C-C motif chemokine 11 (CCL11, Eotaxin) (Matsukura et al. 1999), Ig epsilon chain C region (IGHE) (Stütz & Woisetschlager 1999), Ig gamma-1 chain C region (IGHG1) (Warren et al. 1999) and Ig gamma-4 chain C region (IGHG4) (Hebenstreit et al. 2006).

Preceded by: [p-Y705-STAT3 dimer](#), [p-Y641-STAT6 dimer translocate to nucleus](#)

Literature references

- Stütz, AM., Woisetschläger, M. (1999). Functional synergism of STAT6 with either NF-kappa B or PU.1 to mediate IL-4-induced activation of IgE germline gene transcription. *J. Immunol.*, 163, 4383-91. ↗
- Warren, WD., Roberts, KL., Linehan, LA., Berton, MT. (1999). Regulation of the germline immunoglobulin Cgamma1 promoter by CD40 ligand and IL-4: dual role for tandem NF-kappaB binding sites. *Mol. Immunol.*, 36, 31-44. ↗
- Matsukura, S., Stellato, C., Plitt, JR., Bickel, C., Miura, K., Georas, SN. et al. (1999). Activation of eotaxin gene transcription by NF-kappa B and STAT6 in human airway epithelial cells. *J. Immunol.*, 163, 6876-83. ↗
- Hebenstreit, D., Wirnsberger, G., Horejs-Hoeck, J., Duschl, A. (2006). Signaling mechanisms, interaction partners, and target genes of STAT6. *Cytokine Growth Factor Rev.*, 17, 173-88. ↗

Editions

2015-07-01	Authored	Jupe, S.
2016-09-02	Edited	Jupe, S.
2016-09-02	Reviewed	Leibovich, SJ.

Expression of STAT6-upregulated plasma membrane proteins ↗

Location: [Interleukin-4 and Interleukin-13 signaling](#)

Stable identifier: R-HSA-6793958

Type: omitted

Compartments: nucleoplasm, plasma membrane

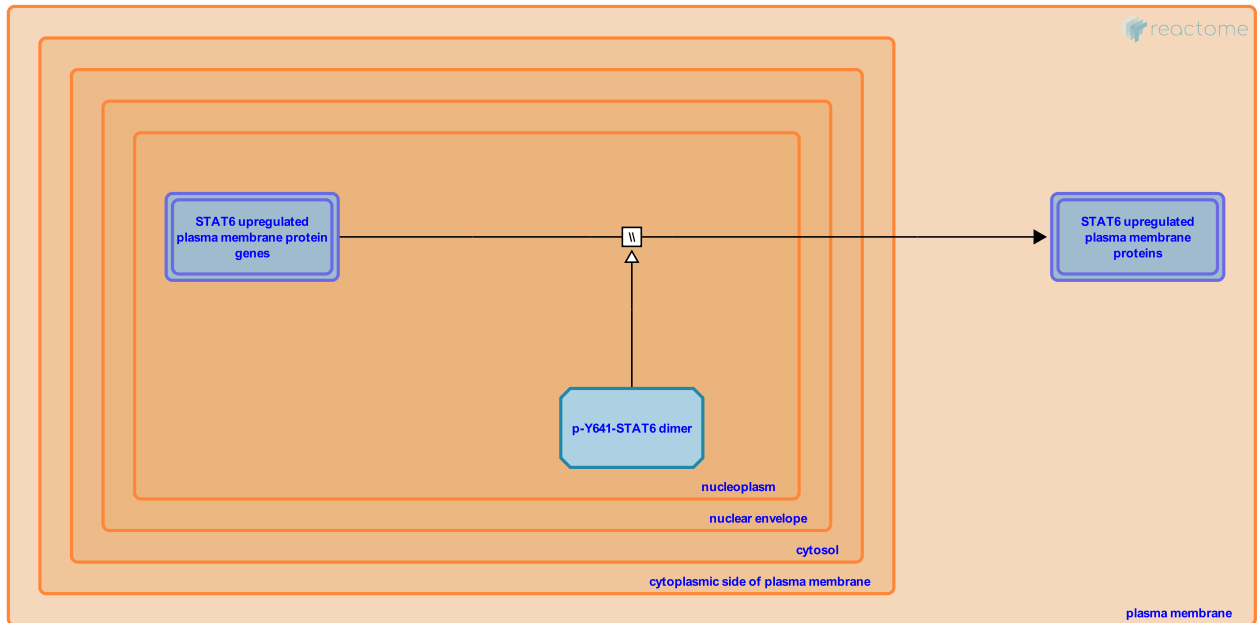

Phosphorylated Signal transducer and activator of transcription 6 (STAT6) dimers translocate to the nucleus and activate the transcription of several genes. In experimental models, targeted gene disruption of STAT6 inhibited airway hyperresponsiveness, airway inflammation, and fibrosis (Blease et al. 2002). STAT6 promotes transcription of the cell surface proteins Interleukin-4 receptor alpha (IL4R) (Matsukura et al. 1999) and Low affinity immunoglobulin epsilon Fc receptor (FCER2) (Takeda et al. 1994, Park et al. 1998). IL4 links the immune system to the opioid system by inducing transcription of the mu- and delta-opioid receptors (MOR, DOR) (Borner et al. 2004, Kraus et al. 2001) and pro-opiomelanocortin (POMC) (Busch-Dienstfertig et al. 2012). Opioid receptor gene expression in T cells is STAT6-dependent while POMC gene expression in lymphocytes is mediated by STAT3 (Busch-Dienstfertig & González-Rodríguez 2013).

Preceded by: [p-Y705-STAT3 dimer](#), [p-Y641-STAT6 dimer translocate to nucleus](#)

Literature references

- Hebenstreit, D., Luft, P., Schmiedlechner, A., Regl, G., Frischauf, AM., Aberger, F. et al. (2003). IL-4 and IL-13 induce SOCS-1 gene expression in A549 cells by three functional STAT6-binding motifs located upstream of the transcription initiation site. *J. Immunol.*, 171, 5901-7. ↗
- Matsukura, S., Stellato, C., Plitt, JR., Bickel, C., Miura, K., Georas, SN. et al. (1999). Activation of eotaxin gene transcription by NF-kappa B and STAT6 in human airway epithelial cells. *J. Immunol.*, 163, 6876-83. ↗
- Takeda, K., Tanaka, T., Shi, W., Matsumoto, M., Minami, M., Kashiwamura, S. et al. (1996). Essential role of Stat6 in IL-4 signalling. *Nature*, 380, 627-30. ↗
- Park, HJ., So, EY., Lee, CE. (1998). Interferon-gamma-induced factor binding to the interleukin-4-responsive element of CD23b promoter in human tonsillar mononuclear cells: role in transient up-regulation of the interleukin-4-induced CD23b mRNA. *Mol. Immunol.*, 35, 239-47. ↗

Börner, C., Wöltje, M., Höllt, V., Kraus, J. (2004). STAT6 transcription factor binding sites with mismatches within the canonical 5'-TTC...GAA-3' motif involved in regulation of delta- and mu-opioid receptors. *J. Neurochem.*, 91, 1493-500. [↗](#)

Editions

2015-07-01	Authored	Jupe, S.
2016-09-02	Edited	Jupe, S.
2016-09-02	Reviewed	Leibovich, SJ.

Expression of STAT3-upregulated extracellular proteins ↗

Location: [Interleukin-4 and Interleukin-13 signaling](#)

Stable identifier: R-HSA-6789615

Type: omitted

Compartments: extracellular region, nucleoplasm

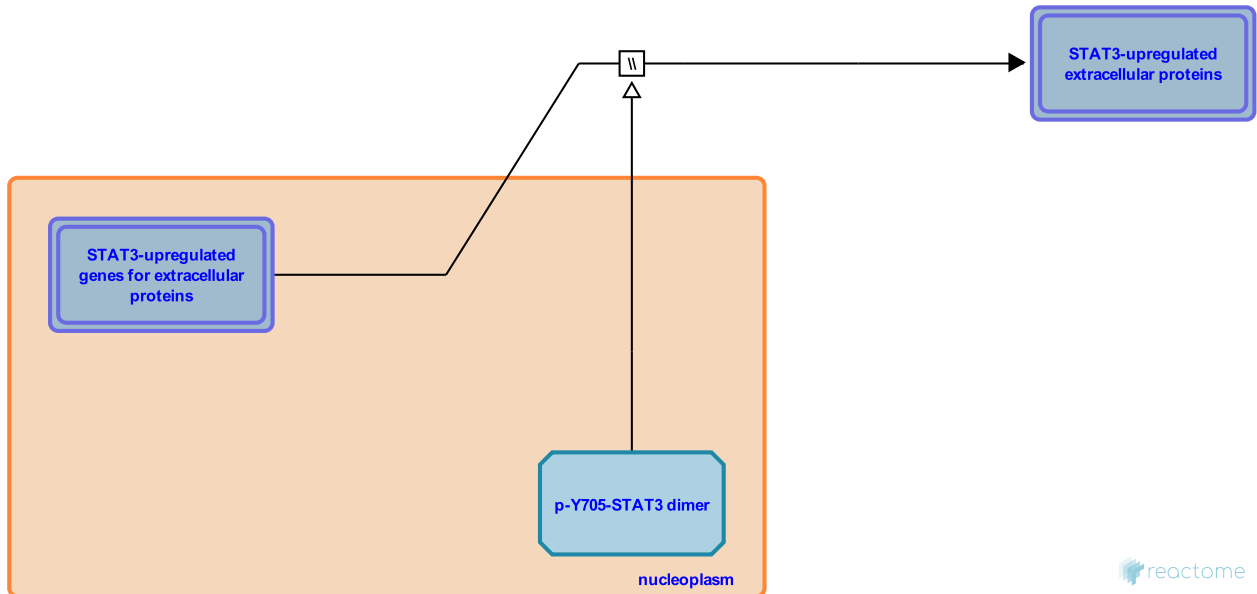

Signal transducer and activator of transcription 3 (STAT3) is a key regulator of gene expression in response to signaling of many cytokines including interleukin-6 (IL6), Oncostatin M (OSM), and leukemia inhibitory factor (LIF). Using microarray techniques, hundreds of genes have been reported as potential STAT3 target genes (Dauer et al. 2005, Hsieh et al. 2005). Some have been confirmed as direct STAT3 targets using genome-wide chromatin immunoprecipitation screening (Snyder et al. 2008, Carpenter & Lo 2014).

Genes for extracellular proteins that are upregulated by STAT3 include Lipopolysaccharide-binding protein (LBP) (Schumann et al. 1996), IL10 (Schaefer et al. 2009), IL23A (Kortylewski et al. 2009), Transforming growth factor beta-1 (TGFB1) (Kinjyo et al. 2006), Matrix metalloproteinase-1 (MMP1, Interstitial collagenase) (Itoh et al. 2006), MMP2 (Xie et al. 2004), MMP3 (Liu et al. 2013), MMP9 (Song et al. 2009), Neutrophil gelatinase-associated lipocalin (LCN2) (Jung et al. 2012, Xu et al. 2015), Pro-opiomelanocortin (POMC) (Bosquet et al. 2000), Serum amyloid A-1 protein (SAA1) (Hagihara et al. 2005), Vascular endothelial growth factor A (VEGFA) (Niu et al. 2002), Fibroblast growth factor 2 (FGF2) (Huang et al. 2013), Hepatocyte growth factor (HGF) (Hung & Elliot 2001), IL17A, IL17F (Durant et al. 2010) and Metalloproteinase inhibitor 1 (TIMP1) (Adamson et al. 2013).

Preceded by: [p-Y705-STAT3 dimer](#), [p-Y641-STAT6 dimer translocate to nucleus](#)

Literature references

- Carpenter, RL., Lo, HW. (2014). STAT3 Target Genes Relevant to Human Cancers. *Cancers (Basel)*, 6, 897-925. ↗
- Schumann, RR., Kirschning, CJ., Unbehauen, A., Aberle, HP., Knope, HP., Lamping, N. et al. (1996). The lipopolysaccharide-binding protein is a secretory class 1 acute-phase protein whose gene is transcriptionally activated by APRF/STAT/3 and other cytokine-inducible nuclear proteins. *Mol. Cell. Biol.*, 16, 3490-503. ↗
- Schaefer, A., Unterberger, C., Frankenberger, M., Lohrum, M., Staples, KJ., Werner, T. et al. (2009). Mechanism of interferon-gamma mediated down-regulation of interleukin-10 gene expression. *Mol. Immunol.*, 46, 1351-9. ↗

Kortylewski, M., Xin, H., Kujawski, M., Lee, H., Liu, Y., Harris, T. et al. (2009). Regulation of the IL-23 and IL-12 balance by Stat3 signaling in the tumor microenvironment. *Cancer Cell*, 15, 114-23. [↗](#)

Kinjyo, I., Inoue, H., Hamano, S., Fukuyama, S., Yoshimura, T., Koga, K. et al. (2006). Loss of SOCS3 in T helper cells resulted in reduced immune responses and hyperproduction of interleukin 10 and transforming growth factor-beta 1. *J. Exp. Med.*, 203, 1021-31. [↗](#)

Editions

2015-07-01	Authored	Jupe, S.
2016-09-02	Edited	Jupe, S.
2016-09-02	Reviewed	Leibovich, SJ.

Expression of STAT3-upregulated plasma membrane proteins ↗

Location: [Interleukin-4 and Interleukin-13 signaling](#)

Stable identifier: R-HSA-6790022

Type: omitted

Compartments: nucleoplasm, plasma membrane

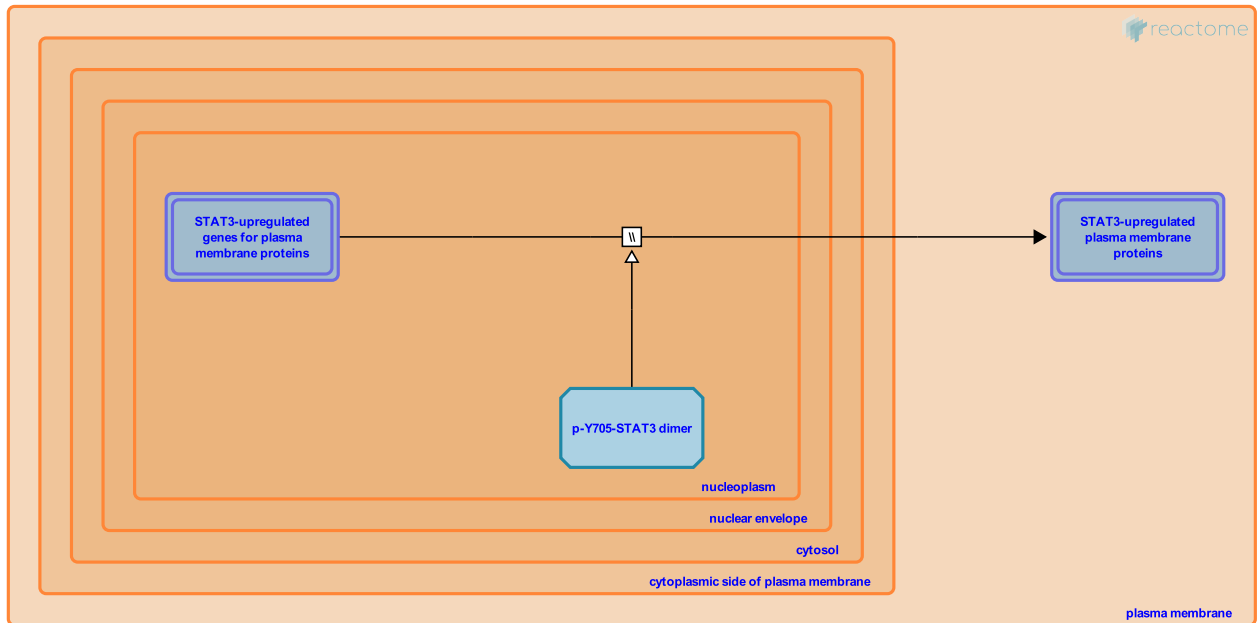

Signal transducer and activator of transcription 3 (STAT3) is a key regulator of gene expression in response to signaling of many cytokines including interleukin-6 (IL6), Oncostatin M, and leukemia inhibitory factor. Using microarray techniques, hundreds of genes have been reported as potential STAT3 target genes (Dauer et al. 2005, Hsieh et al. 2005). Some of these genes have been proven to be direct STAT3 targets using genome-wide chromatin immunoprecipitation screening (Snyder et al. 2008, Carpenter & Lo 2014). Genes for plasma membrane proteins that are upregulated by STAT3 include Intercellular adhesion molecule 1 (ICAM1) (Scuringa et al. 2001), Tumor necrosis factor receptor superfamily member 1B (TNFRSF1B, TNFR2) (Hamilton et al. 2011), Sphingosine 1-phosphate receptor 1 (S1PR1, EDG1) (Lee et al. 2010), Interleukin-6 receptor subunit alpha (IL6R), Interleukin-23 receptor (IL23R) (Durant et al. 2010) and Mucin-1 (MUC1) (Gaemers et al. 2001).

Preceded by: [p-Y705-STAT3 dimer](#), [p-Y641-STAT6 dimer translocate to nucleus](#)

Literature references

- Carpenter, RL., Lo, HW. (2014). STAT3 Target Genes Relevant to Human Cancers. *Cancers (Basel)*, 6, 897-925. ↗
- Kinjyo, I., Inoue, H., Hamano, S., Fukuyama, S., Yoshimura, T., Koga, K. et al. (2006). Loss of SOCS3 in T helper cells resulted in reduced immune responses and hyperproduction of interleukin 10 and transforming growth factor-beta 1. *J. Exp. Med.*, 203, 1021-31. ↗
- Schuringa, JJ., Timmer, H., Luttickhuizen, D., Vellenga, E., Kruijer, W. (2001). c-Jun and c-Fos cooperate with STAT3 in IL-6-induced transactivation of the IL-6 response element (IRE). *Cytokine*, 14, 78-87. ↗
- Hamilton, KE., Simmons, JG., Ding, S., Van Landeghem, L., Lund, PK. (2011). Cytokine induction of tumor necrosis factor receptor 2 is mediated by STAT3 in colon cancer cells. *Mol. Cancer Res.*, 9, 1718-31. ↗
- Lee, H., Deng, J., Kujawski, M., Yang, C., Liu, Y., Herrmann, A. et al. (2010). STAT3-induced S1PR1 expression is crucial for persistent STAT3 activation in tumors. *Nat. Med.*, 16, 1421-8. ↗

Editions

2015-07-01	Authored	Jupe, S.
2016-09-02	Edited	Jupe, S.
2016-09-02	Reviewed	Leibovich, SJ.

Expression of STAT3-upregulated cytosolic proteins ↗

Location: [Interleukin-4 and Interleukin-13 signaling](#)

Stable identifier: R-HSA-6790041

Type: omitted

Compartments: cytosol, nucleoplasm

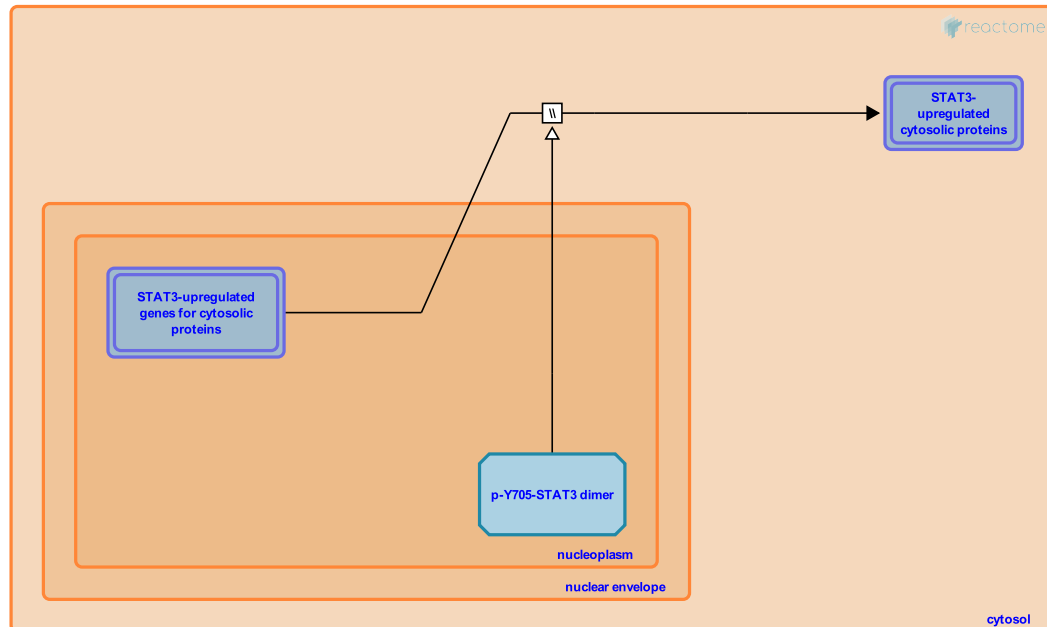

Signal transducer and activator of transcription 3 (STAT3) is a key regulator of gene expression in response to signaling of many cytokines including interleukin-6 (IL6), Oncostatin M, and leukemia inhibitory factor. Using microarray techniques, hundreds of genes have been reported as potential STAT3 target genes (Dauer et al. 2005, Hsieh et al. 2005). Some of these genes have been proven to be direct STAT3 targets using genome-wide chromatin immunoprecipitation screening (Snyder et al. 2008, Carpenter & Lo 2014). Genes for cytoplasmic proteins upregulated by STAT3 include Suppressor of cytokine signaling 3 (SOCS3) (He et al. 2003), Induced myeloid leukemia cell differentiation protein Mcl-1 (MCL1) (Becker et al. 2014), Heat shock protein HSP 90-alpha (HSP90AA1) (Chen et al. 2007), Fascin (FSCN1) (Snyder et al. 2011), Vimentin (VIM) (Wu et al. 2004), Rho-related GTP-binding protein RhoU (RHOU) (Schivavone et al. 2009), RAC-alpha serine/threonine-protein kinase (AKT1) (Xu et al. 2005), Cyclin-dependent kinase inhibitor 1 (CDKN1A) (Bellido et al. 1998), Phosphatidylinositol 3-kinase regulatory subunit alpha (PIK3R1) (Abell et al. 2005), Signal transducer and activator of transcription 1 (STAT1) (Han et al. 2013), Interferon regulatory factor 4 (IRF4) (Durant et al. 2010) and Nitric oxide synthase, inducible (NOS2) (Lo et al. 2005).

Preceded by: [p-Y705-STAT3 dimer](#), [p-Y641-STAT6 dimer translocate to nucleus](#)

Literature references

- Carpenter, RL., Lo, HW. (2014). STAT3 Target Genes Relevant to Human Cancers. *Cancers (Basel)*, 6, 897-925. ↗
- Becker, TM., Boyd, SC., Mijatov, B., Gowrishankar, K., Snoyman, S., Pupo, GM. et al. (2014). Mutant B-RAF-Mcl-1 survival signaling depends on the STAT3 transcription factor. *Oncogene*, 33, 1158-66. ↗
- Chen, XS., Zhang, Y., Wang, JS., Li, XY., Cheng, XK., Zhang, Y. et al. (2007). Diverse effects of Stat1 on the regulation of hsp90alpha gene under heat shock. *J. Cell. Biochem.*, 102, 1059-66. ↗
- Snyder, M., Huang, XY., Zhang, JJ. (2011). Signal transducers and activators of transcription 3 (STAT3) directly regulates cytokine-induced fascin expression and is required for breast cancer cell migration. *J. Biol. Chem.*, 286, 38886-93. ↗

Wu, Y., Diab, I., Zhang, X., Izmailova, ES., Zehner, ZE. (2004). Stat3 enhances vimentin gene expression by binding to the antisilencer element and interacting with the repressor protein, ZBP-89. *Oncogene*, 23, 168-78. [↗](#)

Editions

2015-07-01	Authored	Jupe, S.
2016-09-02	Edited	Jupe, S.
2016-09-02	Reviewed	Leibovich, SJ.

Expression of STAT3-upregulated nuclear proteins ↗

Location: [Interleukin-4 and Interleukin-13 signaling](#)

Stable identifier: R-HSA-6790036

Type: omitted

Compartments: nucleoplasm

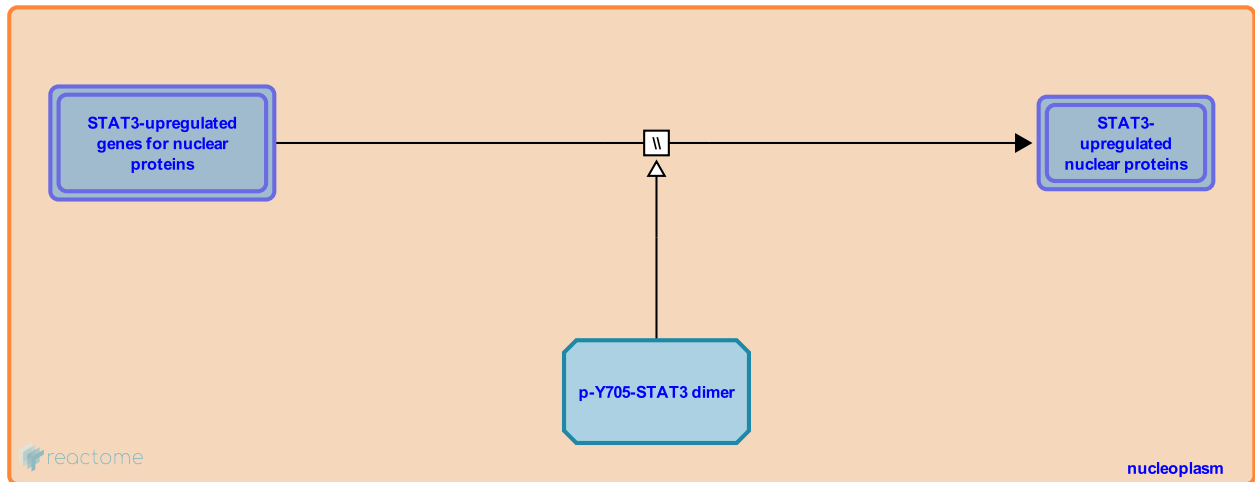

Signal transducer and activator of transcription 3 (STAT3) is a key regulator of gene expression in response to signaling of many cytokines including interleukin-6 (IL6), Oncostatin M, and leukemia inhibitory factor. Using microarray techniques, hundreds of genes have been reported as potential STAT3 target genes (Dauer et al. 2005, Hsieh et al. 2005). Some of these genes have been proven to be direct STAT3 targets using genome-wide chromatin immunoprecipitation screening (Snyder et al. 2008, Carpenter & Lo 2014). Genes for nuclear proteins upregulated by STAT3 include CCAAT/enhancer-binding protein delta (CEBPD) (Hutt et al. 2000), B-cell lymphoma 6 protein (BCL6) (Reljic et al. 2000), Myc proto-oncogene protein (MYC) (Kiuchi et al. 1999, Bowman et al. 2001), Proto-oncogene c-Fos (FOS) (Yang et al. 2003), Hypoxia-inducible factor 1-alpha (HIF1A) (Niu et al. 2008), Transcription factor SOX-2 (SOX2) (Foshay & Gallicano 2008), the homeobox protein NANOG (Okumura et al. 2011), Twist-related protein 1 (TWIST1) (Lo et al. 2007, Cheng et al. 2008), Zinc finger E-box-binding homeobox 1 (ZEB1) (Xiong et al. 2012), POU domain, class 2, transcription factor 1 (POU2F1) (OCT1) (Wang et al. 2013), Baculoviral IAP repeat-containing protein 5 (BIRC5, Survivin) (Gritsko et al. 2006), G1/S-specific cyclin-D1 (CCND1) (Leslie et al. 2006), Serine/threonine-protein kinase PIM1 (Przanowski et al. 2014), Forkhead box protein O1 (FOXO1), FOXO3 (Oh et al. 2011), Nuclear receptor ROR-alpha (RORA), RORC, Basic leucine zipper transcriptional factor ATF-like (BATF) (Durant et al. 2010) and Transcription factor JUNB (Coffer et al. 1995).

Preceded by: [p-Y705-STAT3 dimer](#), [p-Y641-STAT6 dimer translocate to nucleus](#)

Literature references

- Carpenter, RL., Lo, HW. (2014). STAT3 Target Genes Relevant to Human Cancers. *Cancers (Basel)*, 6, 897-925. ↗
- Hutt, JA., O'Rourke, JP., DeWille, J. (2000). Signal transducer and activator of transcription 3 activates CCAAT enhancer-binding protein delta gene transcription in G0 growth-arrested mouse mammary epithelial cells and in involuting mouse mammary gland. *J. Biol. Chem.*, 275, 29123-31. ↗
- Reljic, R., Wagner, SD., Peakman, LJ., Fearon, DT. (2000). Suppression of signal transducer and activator of transcription 3-dependent B lymphocyte terminal differentiation by BCL-6. *J. Exp. Med.*, 192, 1841-8. ↗
- Kiuchi, N., Nakajima, K., Ichiba, M., Fukada, T., Narimatsu, M., Mizuno, K. et al. (1999). STAT3 is required for the gp130-mediated full activation of the c-myc gene. *J. Exp. Med.*, 189, 63-73. ↗

Bowman, T., Broome, MA., Sinibaldi, D., Wharton, W., Pledger, WJ., Sedivy, JM. et al. (2001). Stat3-mediated Myc expression is required for Src transformation and PDGF-induced mitogenesis. *Proc. Natl. Acad. Sci. U.S.A.*, 98, 7319-24. [↗](#)

Editions

2015-07-01	Authored	Jupe, S.
2016-09-02	Edited	Jupe, S.
2016-09-02	Reviewed	Leibovich, SJ.

Expression of BCL2, BCL2L1 ↗

Location: [Interleukin-4 and Interleukin-13 signaling](#)

Stable identifier: R-HSA-6790025

Type: omitted

Compartments: mitochondrial outer membrane, nucleoplasm

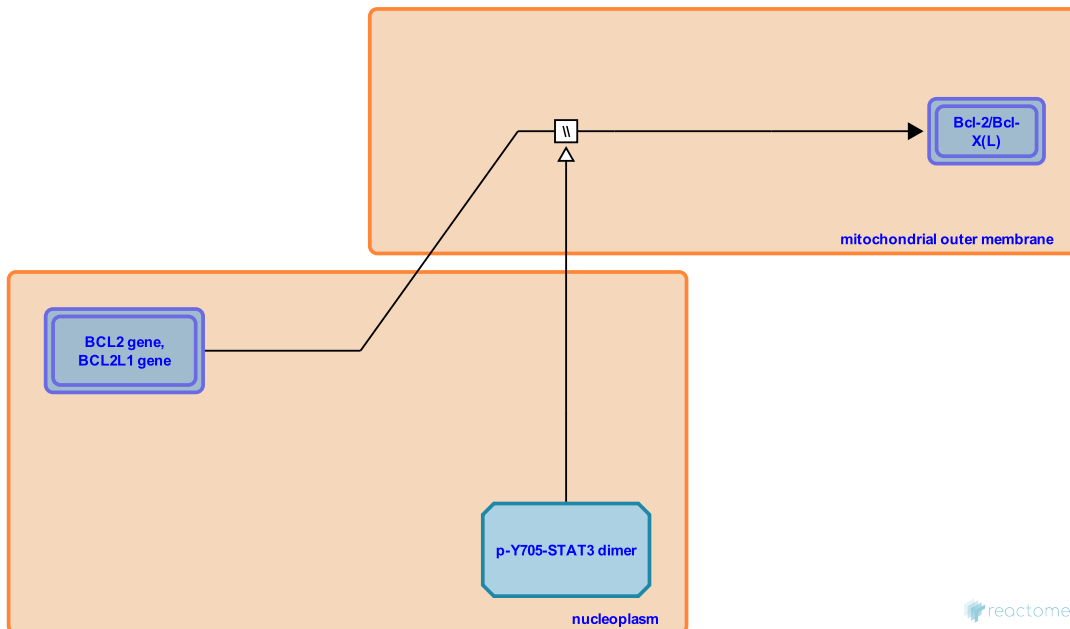

Signal transducer and activator of transcription 3 (STAT3) is a key regulator of gene expression in response to signaling of many cytokines including interleukin-6 (IL6), Oncostatin M, and leukemia inhibitory factor. Using microarray techniques, hundreds of genes have been reported as potential STAT3 target genes (Dauer et al. 2005, Hsieh et al. 2005). Some of these genes have been proven to be direct STAT3 targets using genome-wide chromatin immunoprecipitation screening (Snyder et al. 2008, Carpenter & Lo 2014), including the mitochondrial outer membrane protein genes Apoptosis regulator BCL2 (Bhattacharya et al. 2005) and Bcl-2-like protein 1 (BCL2L1, Bcl-XL) (Catlett-Falcone et al. 1999).

Severe acute respiratory syndrome coronavirus type 1 (SARS-CoV-1) E protein was reported to induce apoptosis by sequestering anti-apoptotic BCL2L1 to membranes of the endoplasmic reticulum (ER) and Golgi, where viral E protein is located (Yang Y et al. 2005).

Preceded by: [p-Y705-STAT3 dimer](#), [p-Y641-STAT6 dimer translocate to nucleus](#)

Literature references

Carpenter, RL., Lo, HW. (2014). STAT3 Target Genes Relevant to Human Cancers. *Cancers (Basel)*, 6, 897-925. ↗

Bhattacharya, S., Ray, RM., Johnson, LR. (2005). STAT3-mediated transcription of Bcl-2, Mcl-1 and c-IAP2 prevents apoptosis in polyamine-depleted cells. *Biochem. J.*, 392, 335-44. ↗

Catlett-Falcone, R., Landowski, TH., Oshiro, MM., Turkson, J., Levitzki, A., Savino, R. et al. (1999). Constitutive activation of Stat3 signaling confers resistance to apoptosis in human U266 myeloma cells. *Immunity*, 10, 105-15. ↗

Editions

2015-07-01	Authored	Jupe, S.
2016-09-02	Edited	Jupe, S.
2016-09-02	Reviewed	Leibovich, SJ.

Expression of HSP90B1 [↗](#)

Location: [Interleukin-4 and Interleukin-13 signaling](#)

Stable identifier: R-HSA-6790038

Type: omitted

Compartments: endoplasmic reticulum lumen, nucleoplasm

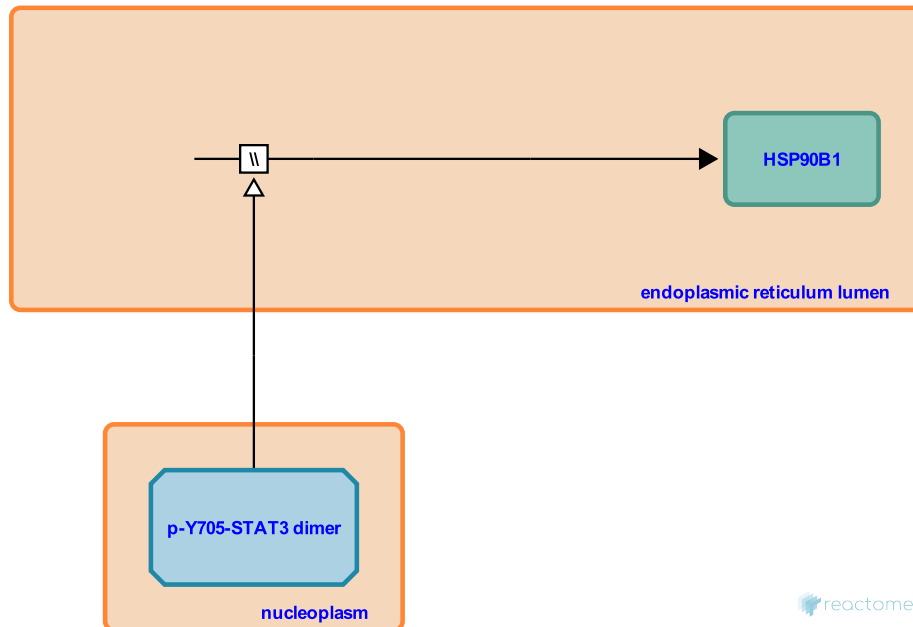

Signal transducer and activator of transcription 3 (STAT3) is a key regulator of gene expression in response to signaling of many cytokines including interleukin-6 (IL6), Oncostatin M, and leukemia inhibitory factor. Using microarray techniques, hundreds of genes have been reported as potential STAT3 target genes (Dauer et al. 2005, Hsieh et al. 2005). Some of these genes have been proven to be direct STAT3 targets using genome-wide chromatin immunoprecipitation screening (Snyder et al. 2008, Carpenter & Lo 2014), including the gene which encodes the endoplasmic reticulum lumen protein Endoplasmin (HSP90B1) (Madamanchi et al. 2001).

Preceded by: [p-Y705-STAT3 dimer](#), [p-Y641-STAT6 dimer translocate to nucleus](#)

Literature references

Carpenter, RL., Lo, HW. (2014). STAT3 Target Genes Relevant to Human Cancers. *Cancers (Basel)*, 6, 897-925. [↗](#)

Madamanchi, NR., Li, S., Patterson, C., Runge, MS. (2001). Thrombin regulates vascular smooth muscle cell growth and heat shock proteins via the JAK-STAT pathway. *J. Biol. Chem.*, 276, 18915-24. [↗](#)

Editions

2015-07-01	Authored	Jupe, S.
2016-09-02	Edited	Jupe, S.
2016-09-02	Reviewed	Leibovich, SJ.

Expression of PTGS2 ↗

Location: [Interleukin-4 and Interleukin-13 signaling](#)

Stable identifier: R-HSA-6790029

Type: omitted

Compartments: endoplasmic reticulum membrane, nucleoplasm

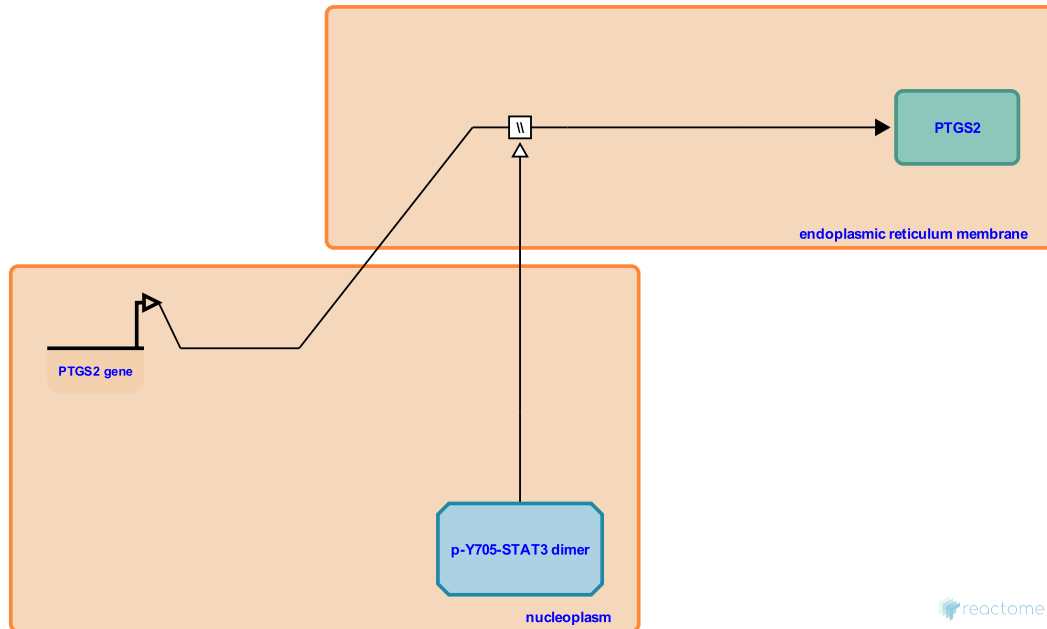

Signal transducer and activator of transcription 3 (STAT3) is a key regulator of gene expression in response to signaling of many cytokines including interleukin-6 (IL6), Oncostatin M, and leukemia inhibitory factor. Using microarray techniques, hundreds of genes have been reported as potential STAT3 target genes (Dauer et al. 2005, Hsieh et al. 2005). Some of these genes have been proven to be direct STAT3 targets using genome-wide chromatin immunoprecipitation screening (Snyder et al. 2008, Carpenter & Lo 2014), including the gene which encodes the endoplasmic reticulum membrane protein Prostaglandin G/H synthase 2 (PTGS2, COX2) (Lo et al. 2010).

Preceded by: [p-Y705-STAT3 dimer](#), [p-Y641-STAT6 dimer translocate to nucleus](#)

Literature references

Carpenter, RL., Lo, HW. (2014). STAT3 Target Genes Relevant to Human Cancers. *Cancers (Basel)*, 6, 897-925. ↗

Lo, HW., Cao, X., Zhu, H., Ali-Osman, F. (2010). Cyclooxygenase-2 is a novel transcriptional target of the nuclear EGFR-STAT3 and EGFRvIII-STAT3 signaling axes. *Mol. Cancer Res.*, 8, 232-45. ↗

Editions

2015-07-01	Authored	Jupe, S.
2016-09-02	Reviewed	Leibovich, SJ.
2016-11-14	Edited	Jupe, S.

Expression of NDN,TP53 ↗

Location: [Interleukin-4 and Interleukin-13 signaling](#)

Stable identifier: R-HSA-6789960

Type: omitted

Compartments: nucleoplasm

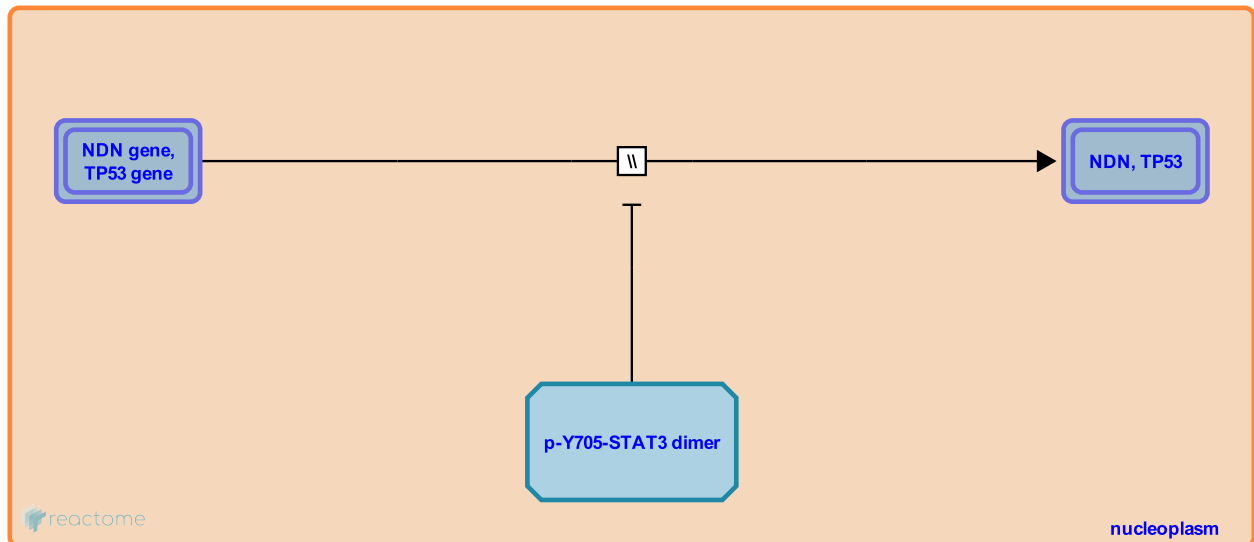

Signal transducer and activator of transcription 3 (STAT3) is a key regulator of gene expression in response to signaling of many cytokines including interleukin-6 (IL6), Oncostatin M, and leukemia inhibitory factor. Using microarray techniques, hundreds of genes have been reported as potential STAT3 target genes (Dauer et al. 2005, Hsieh et al. 2005). Some of these genes have been proven to be direct STAT3 targets using genome-wide chromatin immunoprecipitation screening (Snyder et al. 2008, Carpenter & Lo 2014). Genes encoding nuclear proteins that are downregulated by STAT3 include Necdin (NDN) (Haviland et al. 2011) and Cellular tumor antigen p53 (TP53) (Niu et al. 2005).

Preceded by: [p-Y705-STAT3 dimer](#), [p-Y641-STAT6 dimer translocate to nucleus](#)

Literature references

Haviland, R., Eschrich, S., Bloom, G., Ma, Y., Minton, S., Jove, R. et al. (2011). Necdin, a negative growth regulator, is a novel STAT3 target gene down-regulated in human cancer. *PLoS ONE*, 6, e24923. ↗

Niu, G., Wright, KL., Ma, Y., Wright, GM., Huang, M., Irby, R. et al. (2005). Role of Stat3 in regulating p53 expression and function. *Mol. Cell. Biol.*, 25, 7432-40. ↗

Editions

2015-07-01	Authored	Jupe, S.
2016-09-02	Edited	Jupe, S.
2016-09-02	Reviewed	Leibovich, SJ.

Expression of FASLG ↗

Location: [Interleukin-4 and Interleukin-13 signaling](#)

Stable identifier: R-HSA-6797245

Type: omitted

Compartments: extracellular region, nucleoplasm

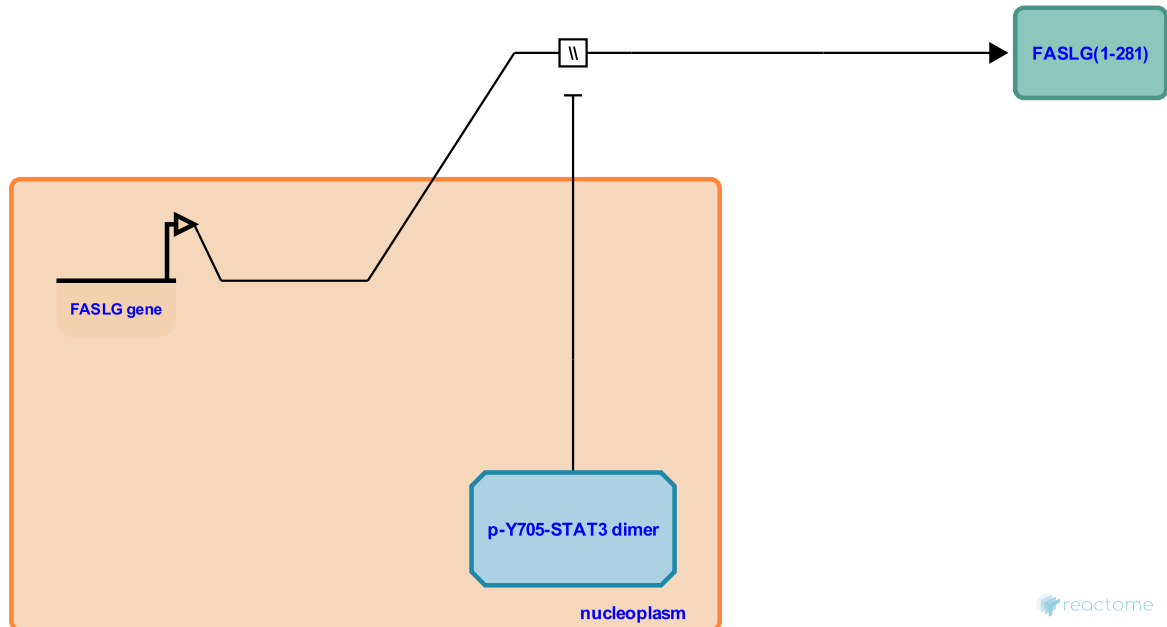

Signal transducer and activator of transcription 3 (STAT3) is a key regulator of gene expression in response to signaling of many cytokines including interleukin-6 (IL6), Oncostatin M, and leukemia inhibitory factor. Using microarray techniques, hundreds of genes have been reported as potential STAT3 target genes (Dauer et al. 2005, Hsieh et al. 2005). Some of these genes have been proven to be direct STAT3 targets using genome-wide chromatin immunoprecipitation screening (Snyder et al. 2008, Carpenter & Lo 2014). Genes that are downregulated by STAT3 include the extracellular protein Tumor necrosis factor ligand superfamily member 6 (FASLG) (Ivanov et al. 2001).

Preceded by: [p-Y705-STAT3 dimer](#), [p-Y641-STAT6 dimer translocate to nucleus](#)

Literature references

Ivanov, VN., Bhoumik, A., Krasilnikov, M., Raz, R., Owen-Schaub, LB., Levy, D. et al. (2001). Cooperation between STAT3 and c-jun suppresses Fas transcription. *Mol. Cell*, 7, 517-28. ↗

Editions

2015-07-01	Authored	Jupe, S.
2016-09-02	Edited	Jupe, S.
2016-09-02	Reviewed	Leibovich, SJ.

SOCS5,(SOCS1) bind IL4RA ↗

Location: [Interleukin-4 and Interleukin-13 signaling](#)

Stable identifier: R-HSA-6785821

Type: binding

Compartments: cytosol, plasma membrane, extracellular region

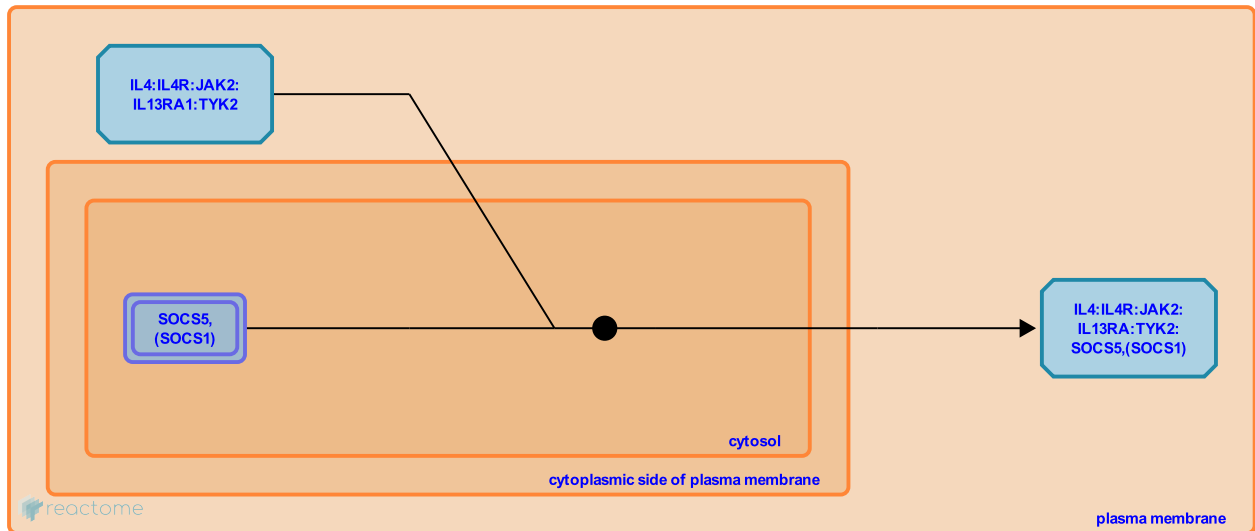

SOCS5 can bind the type I IL4R, reducing its association with JAK1, which results in the inhibition of IL4-mediated STAT6 activation (Seki et al. 2002). Similarly SOCS1 serves as a regulator of IL-4 signaling, diminishing the magnitude and duration of STAT6 activation (Dickensheets et al. 2007).

Preceded by: [IL4:IL4R:JAK2 binds IL13RA1:TYK2](#), [Expression of SOCS1](#)

Literature references

Seki, Y., Hayashi, K., Matsumoto, A., Seki, N., Tsukada, J., Ransom, J. et al. (2002). Expression of the suppressor of cytokine signaling-5 (SOCS5) negatively regulates IL-4-dependent STAT6 activation and Th2 differentiation. *Proc. Natl. Acad. Sci. U.S.A.*, 99, 13003-8. ↗

Davey, GM., Heath, WR., Starr, R. (2006). SOCS1: a potent and multifaceted regulator of cytokines and cell-mediated inflammation. *Tissue Antigens*, 67, 1-9. ↗

Editions

2015-07-01	Authored	Jupe, S.
2016-09-02	Edited	Jupe, S.
2016-09-02	Reviewed	Leibovich, SJ.

IL13 binds IL13RA2 ↗

Location: [Interleukin-4 and Interleukin-13 signaling](#)

Stable identifier: R-HSA-449818

Type: binding

Compartments: extracellular region

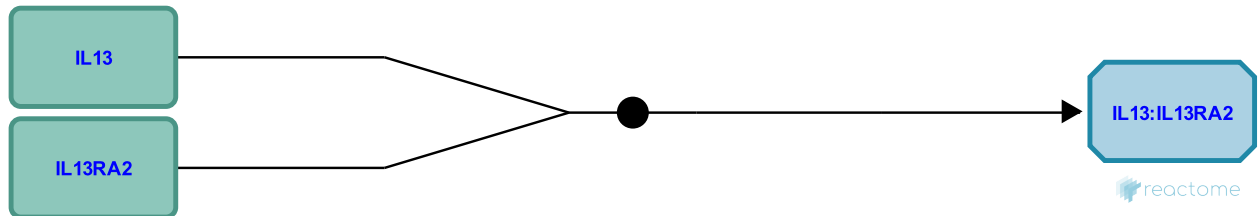

Interleukin-13 receptor alpha 2 (IL13RA2), sometimes called Interleukin-13 binding protein (IL13BP) is a high affinity receptor for IL13 ($K_d = 250$ pmol/L) but is not sufficient to render cells responsive to IL13, even in the presence of IL4R (Donaldson et al. 1998). It is reported to exist in soluble form (Zhang et al. 1997); overexpression reduces STAT6 signaling (Kawakami et al. 2001). Its function may be to prevent IL13 signaling via the functional IL4R:IL13RA1 cell surface receptor. IL13BP is overexpressed in some human cancers and enhances cell invasion (Joshi & Puri 2012).

Literature references

Caput, D., Laurent, P., Kaghad, M., Lelias, JM., Lefort, S., Vita, N. et al. (1996). Cloning and characterization of a specific interleukin (IL)-13 binding protein structurally related to the IL-5 receptor alpha chain. *J Biol Chem*, 271, 16921-6. ↗

Editions

2014-06-04	Authored	Jupe, S.
2016-01-28	Edited	Jupe, S.
2016-01-28	Reviewed	Meldal, BH.

IL13 binds IL13RA:TYK2 ↗

Location: [Interleukin-4 and Interleukin-13 signaling](#)

Stable identifier: R-HSA-6786118

Type: binding

Compartments: cytosol, extracellular region, plasma membrane

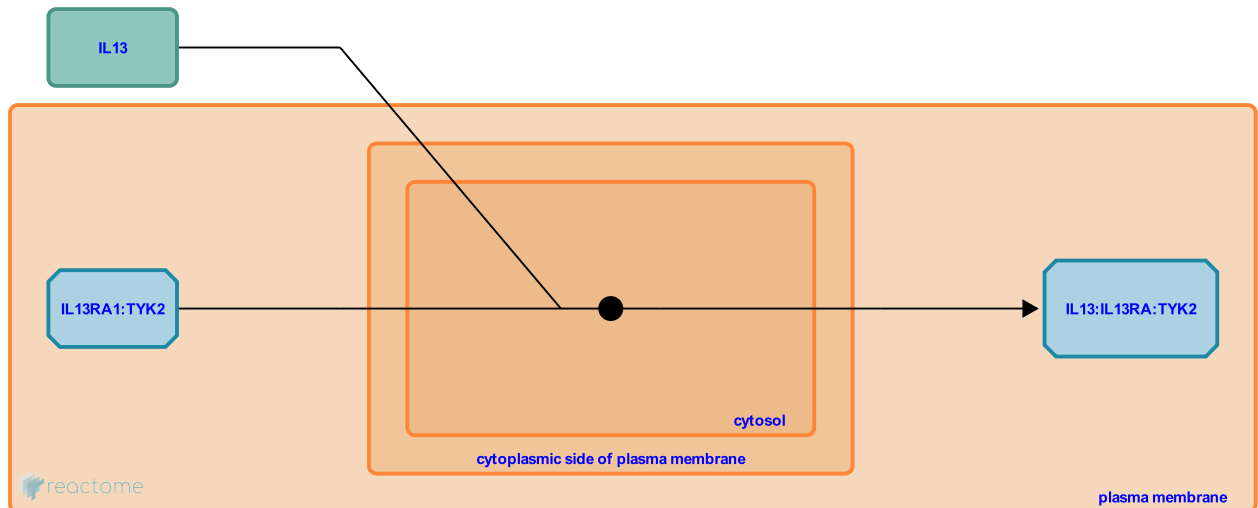

The type II Interleukin-13 (IL13) receptor complex (IL13R2) forms with IL13 binding to Interleukin-13 receptor alpha subunit 1 (IL13RA1), which is constitutively bound to Non-receptor tyrosine kinase 2 (TYK2), followed by recruitment of Interleukin-4 receptor subunit alpha (IL4R), which is associated with Janus kinase 2 (JAK2) (Wang et al. 2009). IL13RA1 binds IL13 with low affinity ($K_d = 2-10$ nmol/L) (Miloux et al. 1997).

Preceded by: [IL13RA1 binds TYK2](#)

Followed by: [IL13:IL13RA:TYK2 binds IL4R:JAK2](#)

Literature references

Miloux, B., Laurent, P., Bonnin, O., Lupker, J., Caput, D., Vita, N. et al. (1997). Cloning of the human IL-13R alpha1 chain and reconstitution with the IL4R alpha of a functional IL-4/IL-13 receptor complex. *FEBS Lett*, 401, 163-6. ↗

Editions

2015-07-01	Authored	Jupe, S.
2016-09-02	Edited	Jupe, S.
2016-09-02	Reviewed	Leibovich, SJ.

IL13:IL13RA:TYK2 binds IL4R:JAK2 ↗

Location: [Interleukin-4 and Interleukin-13 signaling](#)

Stable identifier: R-HSA-6786114

Type: binding

Compartments: cytosol, extracellular region, plasma membrane

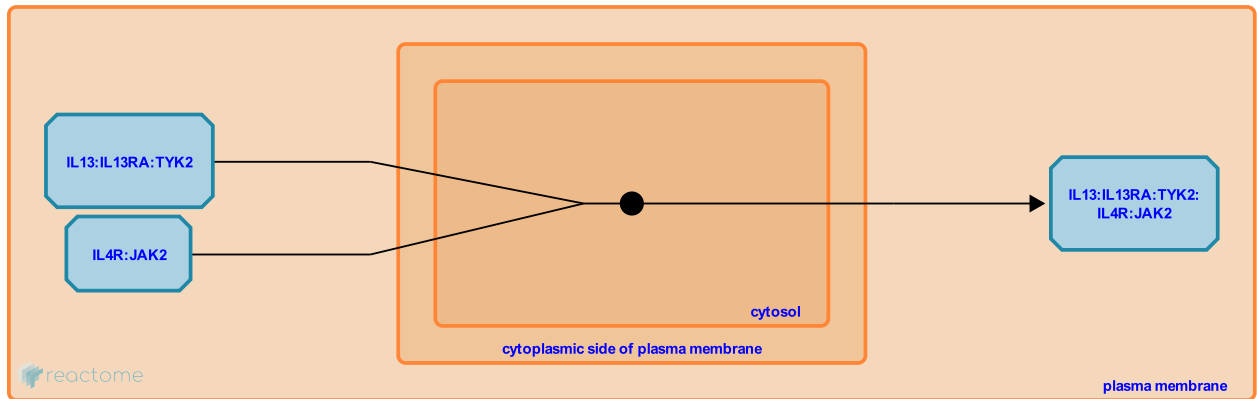

Interleukin-13 receptor alpha subunit (IL13RA1) binds Interleukin-13 (IL13) with a relatively low affinity, but when paired with Interleukin-4 receptor subunit alpha (IL4R), binds with much higher affinity ($K_d = 400$ pmol/L) and forms a functional IL13 receptor that is capable of signaling (Miloux et al. 1997). This type II IL13 receptor complex is also the alternative type II receptor for IL4.

Preceded by: [IL13 binds IL13RA:TYK2](#), [IL4R binds JAK2](#)

Followed by: [JAK1 binds IL4R in IL13-bound IL13R type II](#)

Literature references

Miloux, B., Laurent, P., Bonnin, O., Lupker, J., Caput, D., Vita, N. et al. (1997). Cloning of the human IL-13R alpha1 chain and reconstitution with the IL4R alpha of a functional IL-4/IL-13 receptor complex. *FEBS Lett*, 401, 163-6. ↗

Editions

2015-07-01	Authored	Jupe, S.
2016-09-02	Edited	Jupe, S.
2016-09-02	Reviewed	Leibovich, SJ.

JAK1 binds IL4R in IL13-bound IL13R type II ↗

Location: [Interleukin-4 and Interleukin-13 signaling](#)

Stable identifier: R-HSA-6786110

Type: omitted

Compartments: cytosol, extracellular region, plasma membrane

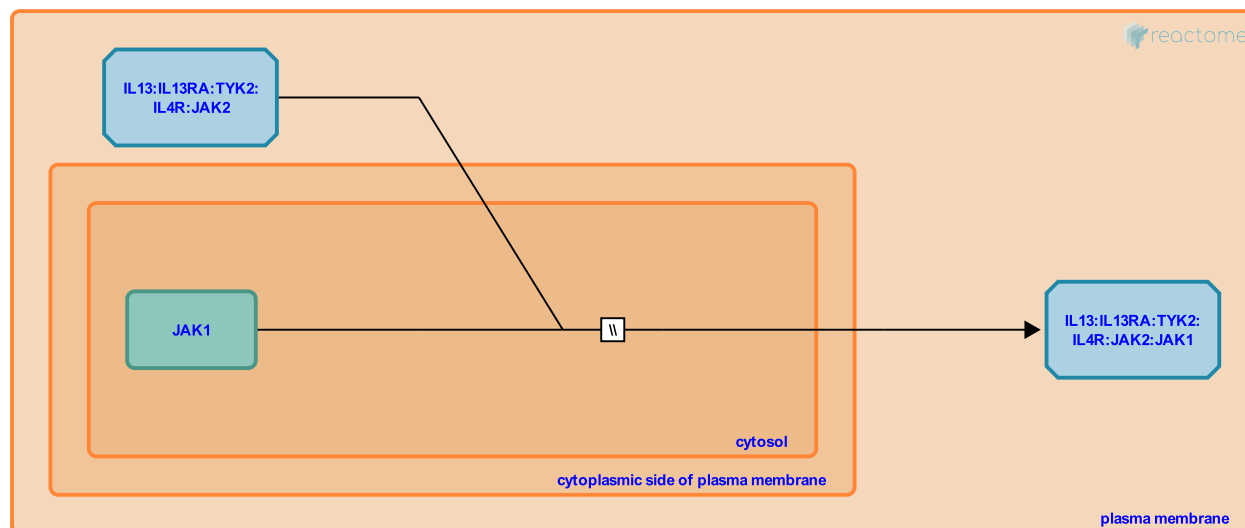

In response to Interleukin-13 (IL13) binding, Janus kinase 1 (JAK1) binds to Interleukin-4 receptor alpha subunit (IL4R) (Roy et al. 2002). IL4R has 2 JAK binding motifs so it is believed that IL4R can bind JAK2 constitutively and additionally bind JAK1 upon ligand binding. The molecular trigger for JAK1 binding is not clear.

Preceded by: [IL13:IL13RA:TYK2 binds IL4R:JAK2](#)

Followed by: [IL4R, IL13RA, JAK2 and TYK2 are tyrosine phosphorylated](#)

Literature references

Roy, B., Bhattacharjee, A., Xu, B., Ford, D., Maizel, AL., Cathcart, MK. (2002). IL-13 signal transduction in human monocytes: phosphorylation of receptor components, association with Jaks, and phosphorylation/activation of Stats. *J. Leukoc. Biol.*, 72, 580-9. ↗

Editions

2015-07-01	Authored	Jupe, S.
2016-09-02	Edited	Jupe, S.
2016-09-02	Reviewed	Leibovich, SJ.

IL4R, IL13RA, JAK2 and TYK2 are tyrosine phosphorylated ↗

Location: [Interleukin-4 and Interleukin-13 signaling](#)

Stable identifier: R-HSA-6786050

Type: omitted

Compartments: cytosol, extracellular region, plasma membrane

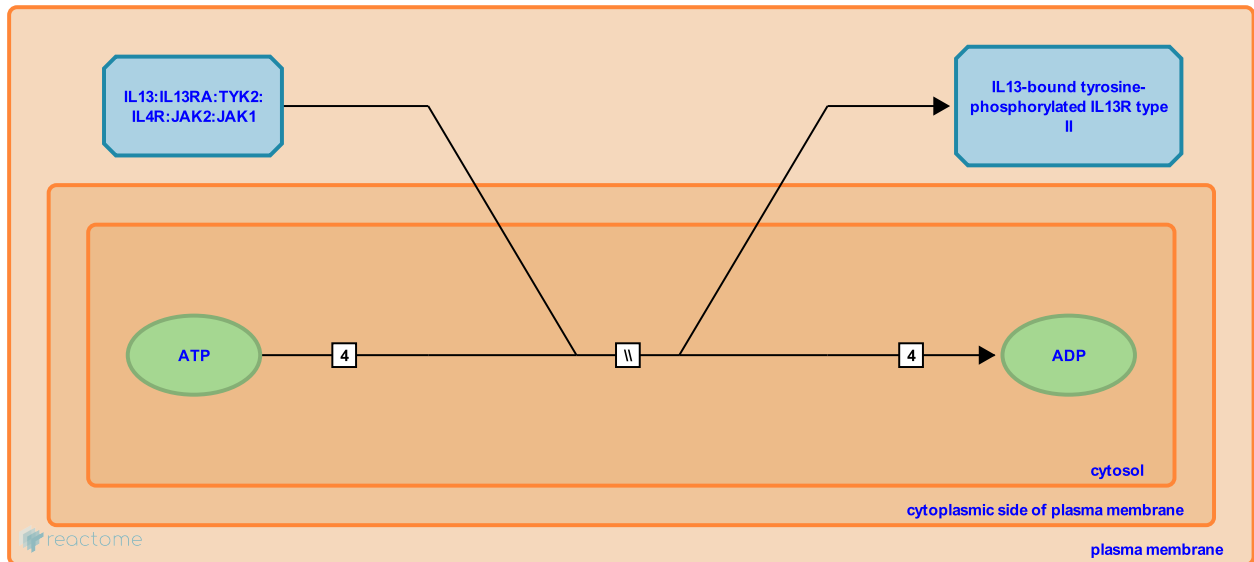

Interleukin-4 receptor alpha subunit (IL4R) and Interleukin-13 receptor subunit alpha 1 (IL13RA1) are phosphorylated on tyrosines in response to Interleukin-13 (IL13) in human blood monocytes (Roy et al. 2002, Bhattacharjee et al. 2013). The associated Janus-kinase (JAK) family kinases JAK2 and TYK2 are also phosphorylated (Roy & Cathcart 1998, Bhattacharjee et al. 2013). Although JAK1 binds to IL4R in response to IL13, it does not appear to be phosphorylated in response to IL13 (Roy & Cathcart 1998, Bhattacharjee et al. 2013).

Preceded by: [JAK1 binds IL4R in IL13-bound IL13R type II](#)

Followed by: [STAT1,STAT3,STAT6 bind IL13:IL13R type II](#)

Literature references

- Roy, B., Bhattacharjee, A., Xu, B., Ford, D., Maizel, AL., Cathcart, MK. (2002). IL-13 signal transduction in human monocytes: phosphorylation of receptor components, association with Jaks, and phosphorylation/activation of Stats. *J. Leukoc. Biol.*, 72, 580-9. ↗
- Bhattacharjee, A., Shukla, M., Yakubenko, VP., Mulya, A., Kundu, S., Cathcart, MK. (2013). IL-4 and IL-13 employ discrete signaling pathways for target gene expression in alternatively activated monocytes/macrophages. *Free Radic. Biol. Med.*, 54, 1-16. ↗
- Roy, B., Cathcart, MK. (1998). Induction of 15-lipoxygenase expression by IL-13 requires tyrosine phosphorylation of Jak2 and Tyk2 in human monocytes. *J. Biol. Chem.*, 273, 32023-9. ↗

Editions

2015-07-01	Authored	Jupe, S.
2016-09-02	Edited	Jupe, S.
2016-09-02	Reviewed	Leibovich, SJ.

STAT1,STAT3,STAT6 bind IL13:IL13R type II ↗

Location: [Interleukin-4 and Interleukin-13 signaling](#)

Stable identifier: R-HSA-6788571

Type: binding

Compartments: cytosol, extracellular region, plasma membrane

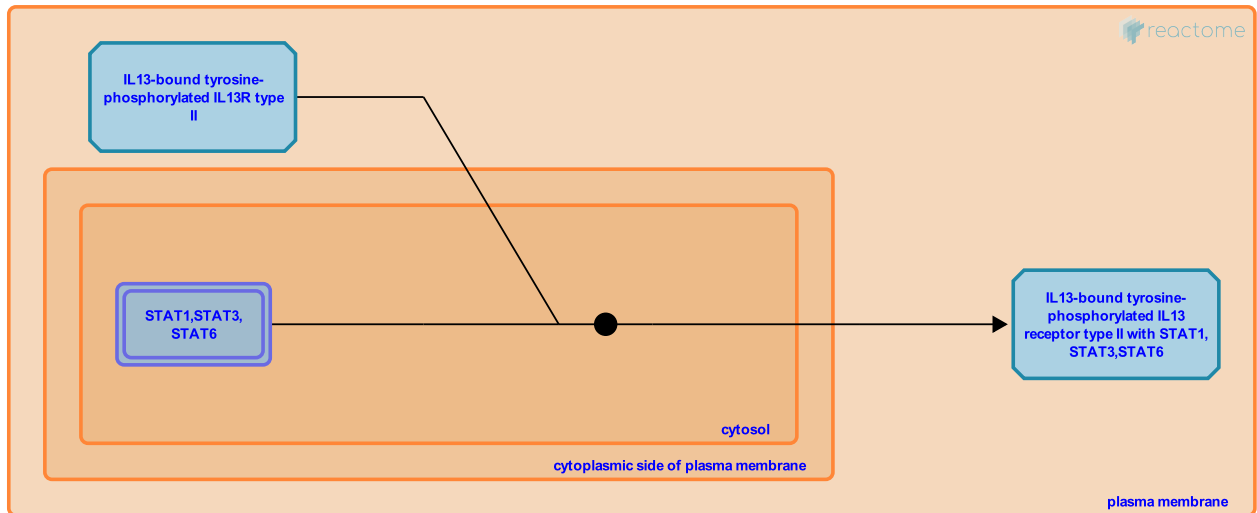

Characterisation of Signal transducer and activator of transcription 6 (STAT6)-deficient mice suggests that Interleukin-13 (IL13) signaling, like Interleukin-4 (IL4) signaling, uses STAT6 (Takeda et al. 1996, Kaplan et al. 1996). In humans STAT6 is activated in response to IL4 and IL13 (Wang et al. 2004) and can bind tyrosine-phosphorylated Interleukin-4 receptor subunit alpha (IL4R) (Hou et al. 1994, Schindler et al. 1996, Mikita et al. 1998), but in response to IL13, STAT6 binds Interleukin-13 receptor subunit alpha 1 (IL13RA1), to be phosphorylated by Non-receptor associated tyrosine kinase 2 (TYK2) (Bhattacharjee et al. 2013).

Binding and phosphorylation of STAT3 has been reported in response to IL13 (Rahaman et al. 2005, Bhattacharjee et al. 2013) but not IL4 (Friedrich et al. 1999), suggesting that STAT3 binding might depend on IL13RA, but recently STAT3 was reported to associate with IL4R and be phosphorylated by Janus kinase 2 (JAK2) (Umeshita-Suyama et al. 2000, Bhattacharjee et al. 2013).

STAT1 is activated in response to IL13 (Wang et al. 2004) and reported to bind IL13RA1 and be phosphorylated by TYK2 (Bhattacharjee et al. 2013).

Preceded by: [IL4R](#), [IL13RA](#), [JAK2](#) and [TYK2](#) are tyrosine phosphorylated

Followed by: [STAT1,STAT3,STAT6](#) phosphorylation

Literature references

- Wang, IM., Lin, H., Goldman, SJ., Kobayashi, M. (2004). STAT-1 is activated by IL-4 and IL-13 in multiple cell types. *Mol. Immunol.*, 41, 873-84. ↗
- Bhattacharjee, A., Shukla, M., Yakubenko, VP., Mulya, A., Kundu, S., Cathcart, MK. (2013). IL-4 and IL-13 employ discrete signaling pathways for target gene expression in alternatively activated monocytes/macrophages. *Free Radic. Biol. Med.*, 54, 1-16. ↗

Editions

2015-07-01	Authored	Jupe, S.
2016-09-02	Edited	Jupe, S.
2016-09-02	Reviewed	Leibovich, SJ.

STAT1,STAT3,STAT6 phosphorylation ↗

Location: [Interleukin-4 and Interleukin-13 signaling](#)

Stable identifier: R-HSA-6788582

Type: transition

Compartments: plasma membrane, cytosol, extracellular region

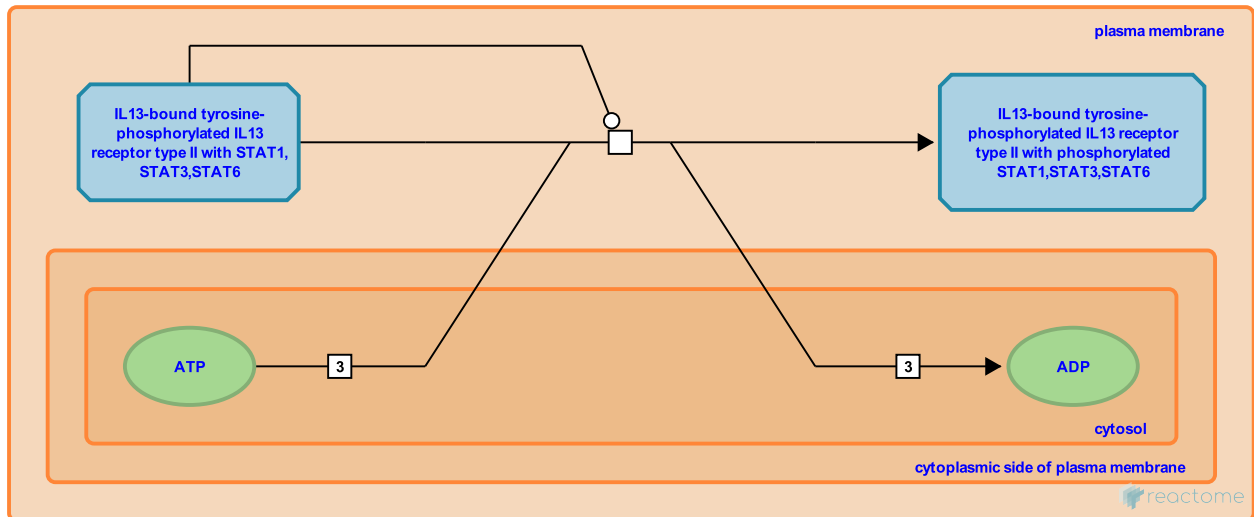

Once bound to the Interleukin-13 (IL13) type II receptor, Signal transducer and activator of transcription 3 (STAT3) is tyrosine phosphorylated by Janus kinase 2 (JAK2), while STAT1 and STAT6 are phosphorylated by Non-receptor tyrosine kinase 2 (TYK2) (Bhattacharjee et al. 2013).

Preceded by: [STAT1,STAT3,STAT6 bind IL13:IL13R type II](#)

Followed by: [p-Y-STATs dissociate](#)

Literature references

Bhattacharjee, A., Shukla, M., Yakubenko, VP., Mulya, A., Kundu, S., Cathcart, MK. (2013). IL-4 and IL-13 employ discrete signaling pathways for target gene expression in alternatively activated monocytes/macrophages. *Free Radic. Biol. Med.*, 54, 1-16. ↗

Editions

2015-07-01	Authored	Jupe, S.
2016-09-02	Edited	Jupe, S.
2016-09-02	Reviewed	Leibovich, SJ.

p-Y-STATs dissociate ↗

Location: [Interleukin-4 and Interleukin-13 signaling](#)

Stable identifier: R-HSA-6788628

Type: omitted

Compartments: cytosol, extracellular region, plasma membrane

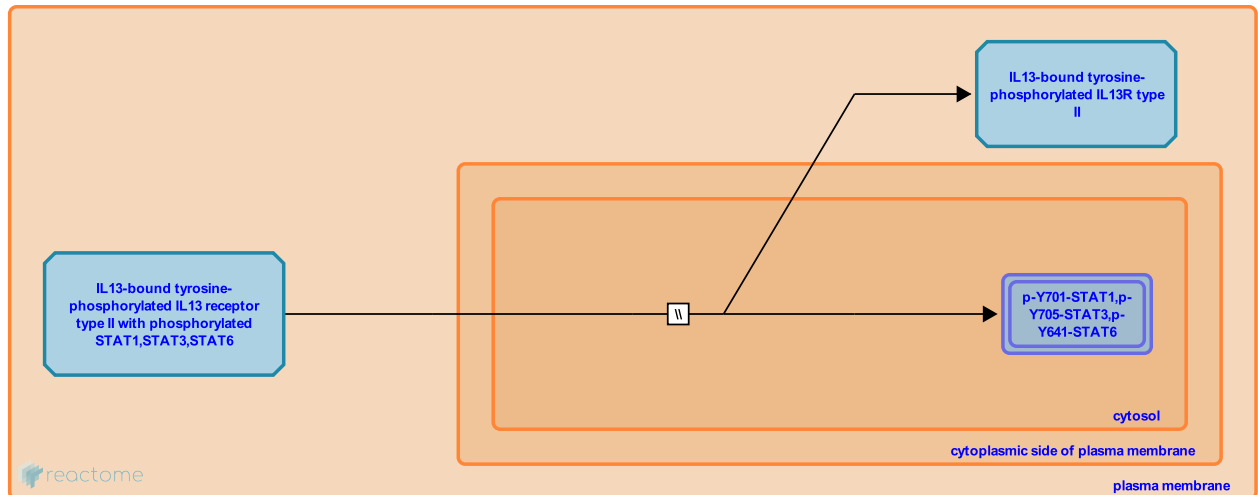

Once phosphorylated, Signal transducer and activator of transcription family members (STATs) dissociate from the receptor complex and translocate to the nucleus.

Preceded by: [STAT1,STAT3,STAT6 phosphorylation](#)

Followed by: [p-Y-STATs dimerize](#)

Literature references

Harrison, DA. (2012). The Jak/STAT pathway. *Cold Spring Harb Perspect Biol*, 4. ↗

Editions

2015-07-01	Authored	Jupe, S.
2016-09-02	Edited	Jupe, S.
2016-09-02	Reviewed	Leibovich, SJ.

p-Y-STATs dimerize ↗

Location: [Interleukin-4 and Interleukin-13 signaling](#)

Stable identifier: R-HSA-6788622

Type: omitted

Compartments: cytosol

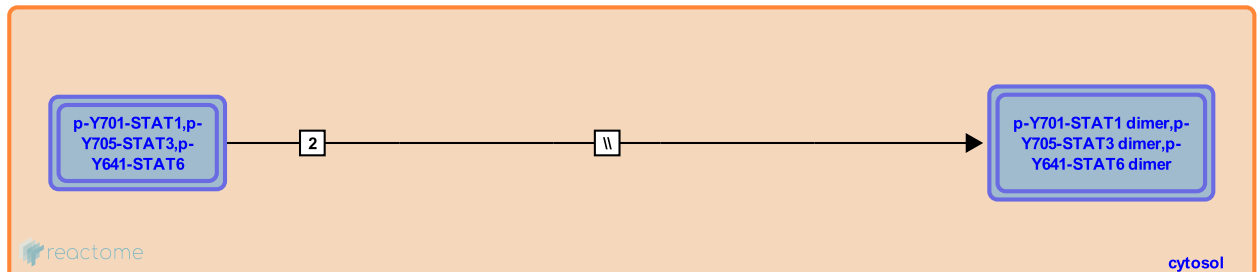

Phosphorylated Signal transducer and activator of transcription 3 (STAT3) dimerizes after dissociating from the interleukin-19 (IL19) receptor complex (Akira et al. 1994) or Interleukin-22 (IL22) receptor complex (Lagos-Quintana et al. 2003, Sestito et al. 2011).

According to the classical model, phosphorylated Signal transducer and activator of transcription (STAT) monomers associate in an active dimer form, which is stabilized by the reciprocal interactions between a phosphorylated tyrosine residue of one and the SH2 domain of the other monomer (Shuai et al. 1994). These dimers then translocate to the nucleus (Akira et al. 1994). Recently an increasing number of studies have demonstrated the existence of STAT dimers in unstimulated cell states and the capability of STATs to exert biological functions independently of phosphorylation (Braunstein et al. 2003, Li et al. 2008, Santos & Costas-Pereira 2011). As phosphorylation of STATs is not unequivocally required for its subsequent translocation to the nucleus, this event is shown as an uncertain process.

Preceded by: [p-Y-STATs dissociate](#)

Followed by: [p-Y-STATs translocate to nucleus](#)

Literature references

Shuai, K., Horvath, CM., Huang, LH., Qureshi, SA., Cowburn, D., Darnell JE, Jr. (1994). Interferon activation of the transcription factor Stat91 involves dimerization through SH2-phosphotyrosyl peptide interactions. *Cell*, 76, 821-8 . ↗

Braunstein, J., Brutsaert, S., Olson, R., Schindler, C. (2003). STATs dimerize in the absence of phosphorylation. *J. Biol. Chem.*, 278, 34133-40. ↗

Editions

2015-07-01	Authored	Jupe, S.
2016-09-02	Edited	Jupe, S.
2016-09-02	Reviewed	Leibovich, SJ.

p-Y-STATs translocate to nucleus ↗

Location: [Interleukin-4 and Interleukin-13 signaling](#)

Stable identifier: R-HSA-6788623

Type: omitted

Compartments: cytosol, nucleoplasm

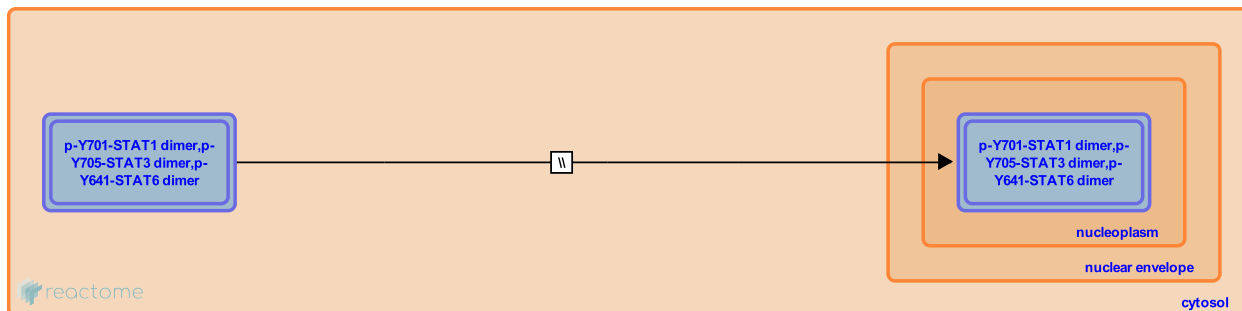

The classical model of JAK-STAT signaling suggests that phosphorylated Signal transducer and activator of transcription (STAT) translocates to the nucleus (Akira et al. 1994) where it binds DNA to mediate the effects of Interleukin-13 (IL13) on expression of cytokines, soluble mediators and cell surface molecules by cells of myeloid origin, with important consequences for their ability to activate and sustain immune and inflammatory responses.

Recently, STATs have been shown to shuttle freely between the cytoplasm and the nucleus, independent of tyrosine phosphorylation (Liu et al. 2005, Li 2008, Reich 2013). Binding of unphosphorylated STAT3 to DNA has been reported (Nkansah et al. 2013). As it is not clear what triggers nuclear accumulation of STATs in response to IL13, this event is shown as an uncertain process.

Preceded by: [p-Y-STATs dimerize](#)

Followed by: [Expression of IL13-upregulated plasma membrane proteins](#)

Literature references

Akira, S., Nishio, Y., Inoue, M., Wang, XJ., Wei, S., Matsusaka, T. et al. (1994). Molecular cloning of APRF, a novel IFN-stimulated gene factor 3 p91-related transcription factor involved in the gp130-mediated signaling pathway. *Cell*, 77, 63-71. ↗

Editions

2015-07-01	Authored	Jupe, S.
2016-09-02	Edited	Jupe, S.
2016-09-02	Reviewed	Leibovich, SJ.

Expression of IL4, IL13-upregulated extracellular proteins ↗

Location: [Interleukin-4 and Interleukin-13 signaling](#)

Stable identifier: R-HSA-6785895

Type: omitted

Compartments: extracellular region, nucleoplasm

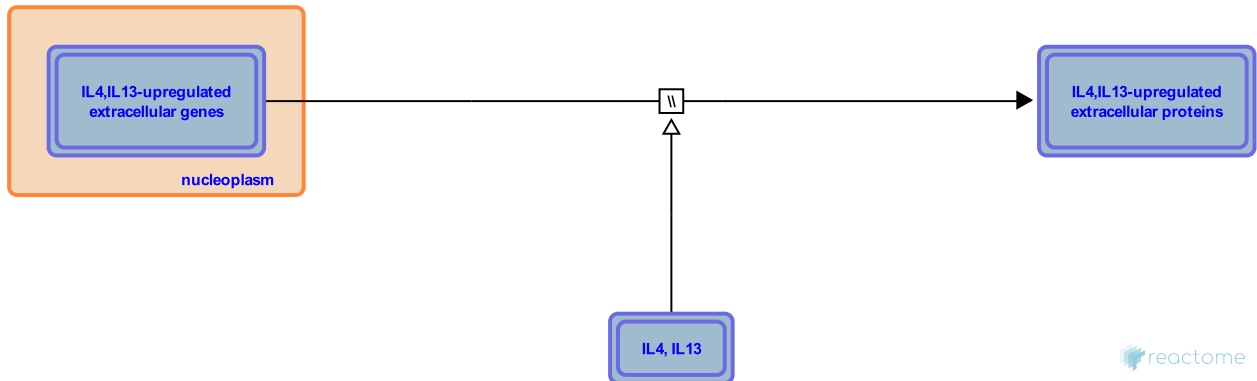

In human peripheral blood monocytes IL4 and IL13 significantly upregulate the levels of several extracellular proteins involved in inflammatory resolution including fibronectin (FN1), coagulation factor XIII (FXIII), annexin 1 (ANXA1), collagen type 1 alpha 2 (COL1A2), laminin alpha-5 (LAMA5) and C-C motif chemokine 22 (CCL22) (Chaitidis et al. 2005, Jinnin et al. 2004, Yakubenko et al. 2011).

Literature references

Chaitidis, P., O'Donnell, V., Kuban, RJ., Bermudez-Fajardo, A., Ungethuen, U., Kühn, H. (2005). Gene expression alterations of human peripheral blood monocytes induced by medium-term treatment with the TH2-cytokines interleukin-4 and -13. *Cytokine*, 30, 366-77. ↗

Yakubenko, VP., Bhattacharjee, A., Pluskota, E., Cathcart, MK. (2011). $\alpha M\beta 2$, integrin activation prevents alternative activation of human and murine macrophages and impedes foam cell formation. *Circ. Res.*, 108, 544-54. ↗

Editions

2015-07-01	Authored	Jupe, S.
2016-09-02	Edited	Jupe, S.
2016-09-02	Reviewed	Leibovich, SJ.

Expression of HSPA8, ALOX15 ↗

Location: [Interleukin-4 and Interleukin-13 signaling](#)

Stable identifier: R-HSA-6797269

Type: omitted

Compartments: cytosol, nucleoplasm

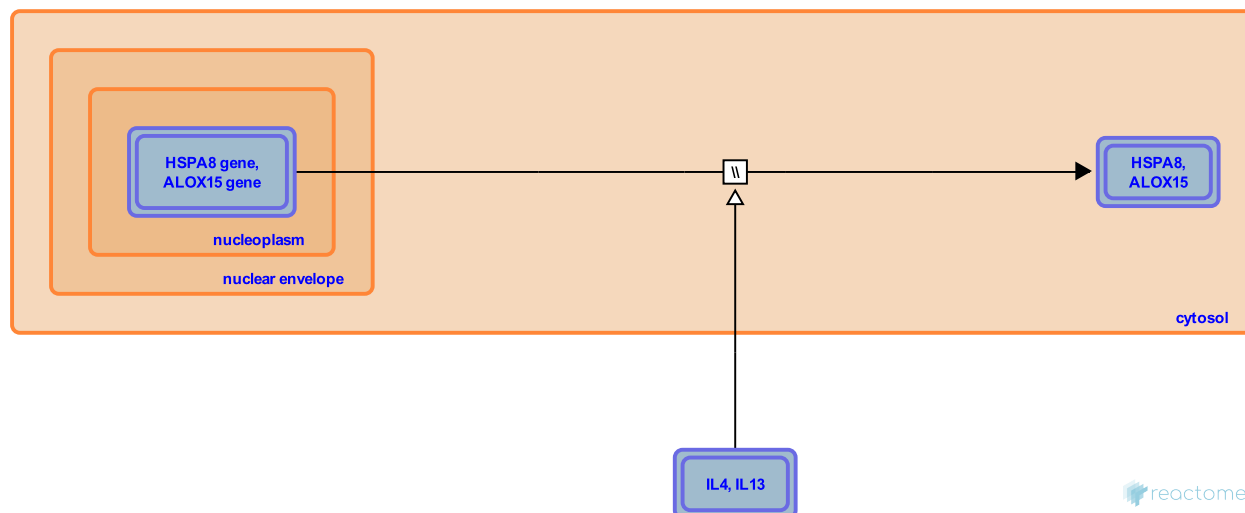

In human peripheral blood monocytes Interleukin-4 (IL4) and IL13 significantly upregulate the levels of proteins involved in inflammatory resolution including the cytoplasmic proteins 15-lipoxygenase (ALOX15) and heat shock protein 8 (HSP8) (Chaitidis et al. 2005, Yakubenko et al. 2011).

Literature references

Yakubenko, VP., Bhattacharjee, A., Pluskota, E., Cathcart, MK. (2011). α M β 2, integrin activation prevents alternative activation of human and murine macrophages and impedes foam cell formation. *Circ. Res.*, 108, 544-54. ↗

Chaitidis, P., O'Donnell, V., Kuban, RJ., Bermudez-Fajardo, A., Ungethuen, U., Kühn, H. (2005). Gene expression alterations of human peripheral blood monocytes induced by medium-term treatment with the TH2-cytokines interleukin-4 and -13. *Cytokine*, 30, 366-77. ↗

Editions

2015-07-01	Authored	Jupe, S.
2016-09-02	Edited	Jupe, S.
2016-09-02	Reviewed	Leibovich, SJ.

Expression of CD36 [↗](#)

Location: [Interleukin-4 and Interleukin-13 signaling](#)

Stable identifier: R-HSA-6797267

Type: uncertain

Compartments: plasma membrane, nucleoplasm

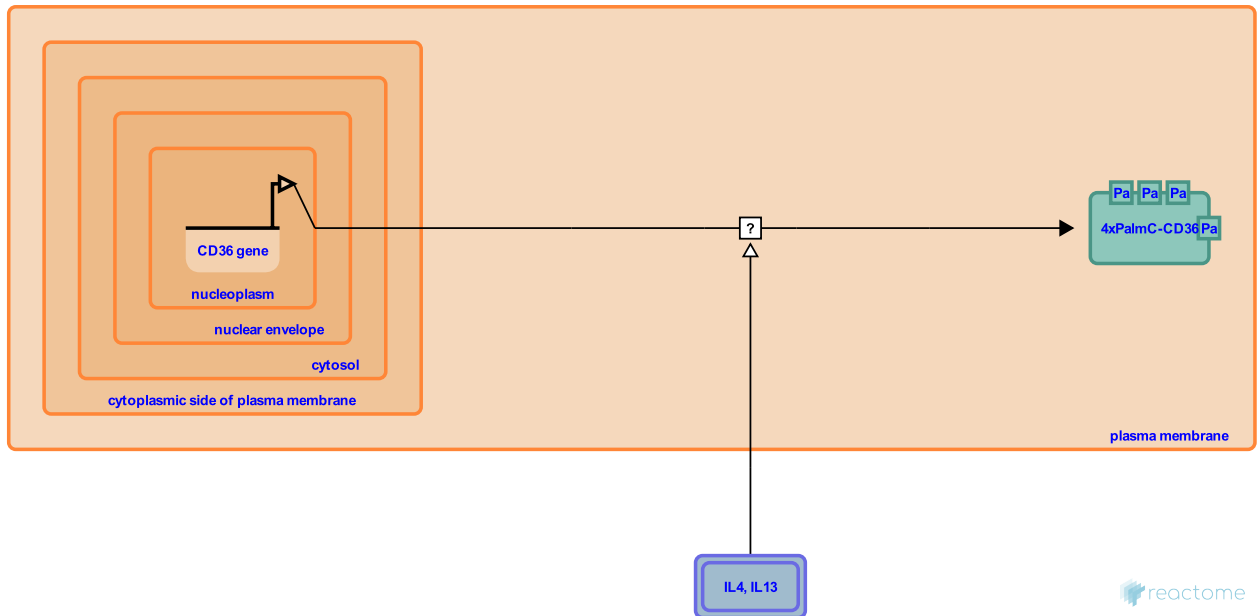

In human peripheral blood monocytes Interleukin-4 (IL4) and IL13 significantly upregulates the levels of proteins involved in inflammatory resolution including the cell surface protein CD36 (Berry et al. 2007).

Literature references

Berry, A., Ballard, P., Coste, A., Olganier, D., Lagane, C., Authier, H. et al. (2007). IL-13 induces expression of CD36 in human monocytes through PPARgamma activation. *Eur. J. Immunol.*, 37, 1642-52. [↗](#)

Editions

2015-07-01	Authored	Jupe, S.
2016-09-02	Edited	Jupe, S.
2016-09-02	Reviewed	Leibovich, SJ.

Expression of HMOX1 ↗

Location: [Interleukin-4 and Interleukin-13 signaling](#)

Stable identifier: R-HSA-6797268

Type: omitted

Compartments: nucleoplasm, endoplasmic reticulum membrane

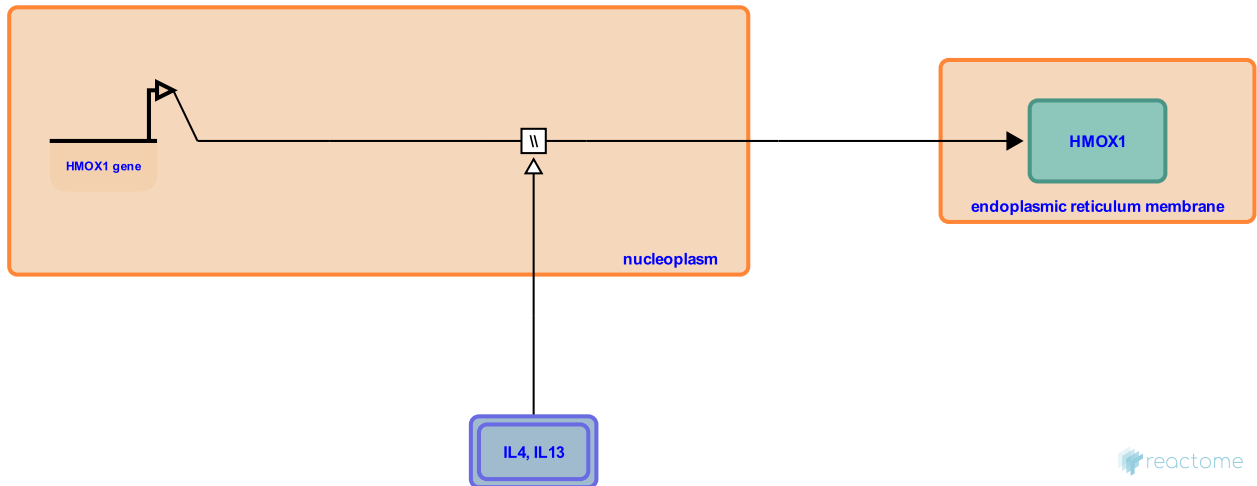

In human peripheral blood monocytes Interleukin-4 (IL4) and IL13 significantly upregulate the levels of proteins involved in inflammatory resolution, including the ER membrane protein 15-lipoxygenase (ALOX15) (Chaitidis et al. 2005).

Literature references

Chaitidis, P., O'Donnell, V., Kuban, RJ., Bermudez-Fajardo, A., Ungethuen, U., Kühn, H. (2005). Gene expression alterations of human peripheral blood monocytes induced by medium-term treatment with the TH2-cytokines interleukin-4 and -13. *Cytokine*, 30, 366-77. ↗

Editions

2015-07-01	Authored	Jupe, S.
2016-09-02	Edited	Jupe, S.
2016-09-02	Reviewed	Leibovich, SJ.

Expression of MAOA ↗

Location: [Interleukin-4 and Interleukin-13 signaling](#)

Stable identifier: R-HSA-6797271

Type: omitted

Compartments: mitochondrial outer membrane, nucleoplasm

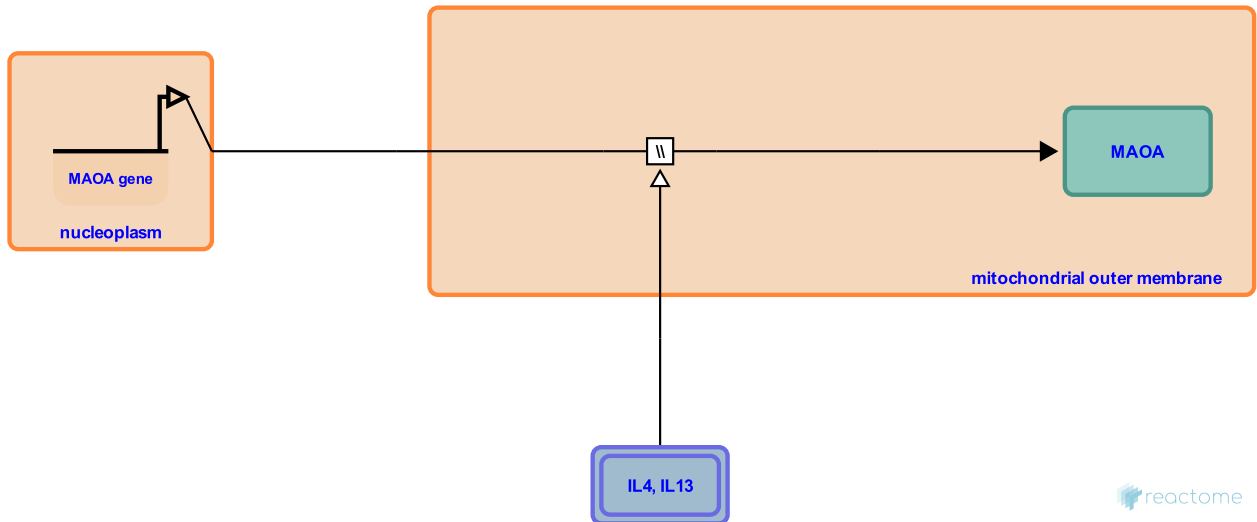

In human peripheral blood monocytes Interleukin-4 (IL4) and IL13 significantly upregulate the levels of proteins involved in inflammatory resolution including the mitochondrial outer membrane protein monoamine oxidase-A (MAOA) (Chaitidis et al. 2005).

Literature references

Chaitidis, P., O'Donnell, V., Kuban, RJ., Bermudez-Fajardo, A., Ungethuen, U., Kühn, H. (2005). Gene expression alterations of human peripheral blood monocytes induced by medium-term treatment with the TH2-cytokines interleukin-4 and -13. *Cytokine*, 30, 366-77. ↗

Editions

2015-07-01	Authored	Jupe, S.
2016-09-02	Edited	Jupe, S.
2016-09-02	Reviewed	Leibovich, SJ.

Expression of IL4,IL13-downregulated extracellular genes ↗

Location: [Interleukin-4 and Interleukin-13 signaling](#)

Stable identifier: R-HSA-6789524

Type: omitted

Compartments: extracellular region, nucleoplasm

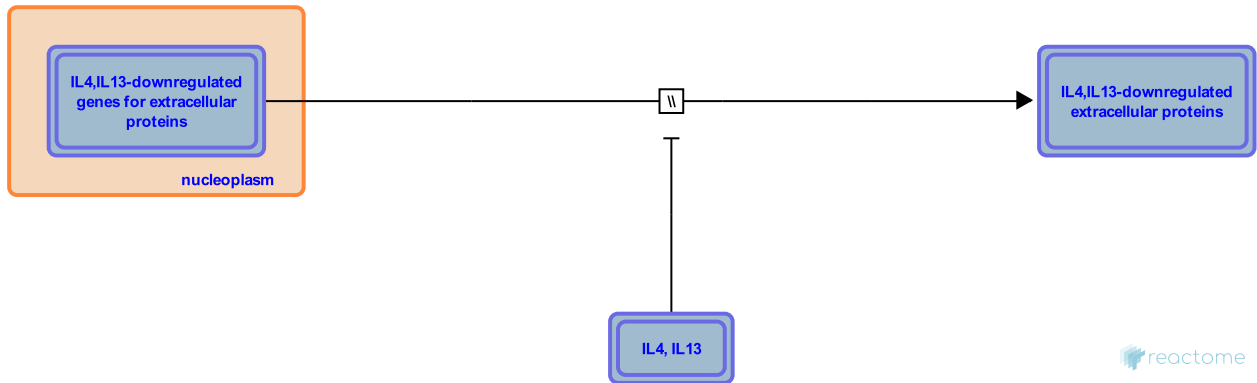

In human peripheral blood, monocytes Interleukin-4 (IL4) and Interleukin-13 significantly downregulate the expression of classical proinflammatory signal transducers, such as Interleukin-1 (IL1), Interleukin-6, Interleukin-8, Interleukin-18, C-C motif chemokine 2 (CCL2) and Tumor necrosis factor (TNF). Expression of Prostaglandin G/H synthase 2 (PTGS2, COX2) and Arachidonate 5-lipoxygenase (ALOX5), enzymes involved in the biosynthesis of the proinflammatory eicosanoids, is also attenuated (Chatidis et al. 2005).

This is a black box event because the mechanism of gene regulation is not fully defined.

Literature references

Chatidis, P., O'Donnell, V., Kuban, RJ., Bermudez-Fajardo, A., Ungethuen, U., Kühn, H. (2005). Gene expression alterations of human peripheral blood monocytes induced by medium-term treatment with the TH2-cytokines interleukin-4 and -13. *Cytokine*, 30, 366-77. ↗

Editions

2015-07-01	Authored	Jupe, S.
2016-09-02	Edited	Jupe, S.
2016-09-02	Reviewed	Leibovich, SJ.

Expression of IL18, ALOX5 ↗

Location: [Interleukin-4 and Interleukin-13 signaling](#)

Stable identifier: R-HSA-6797293

Type: omitted

Compartments: cytosol, nucleoplasm

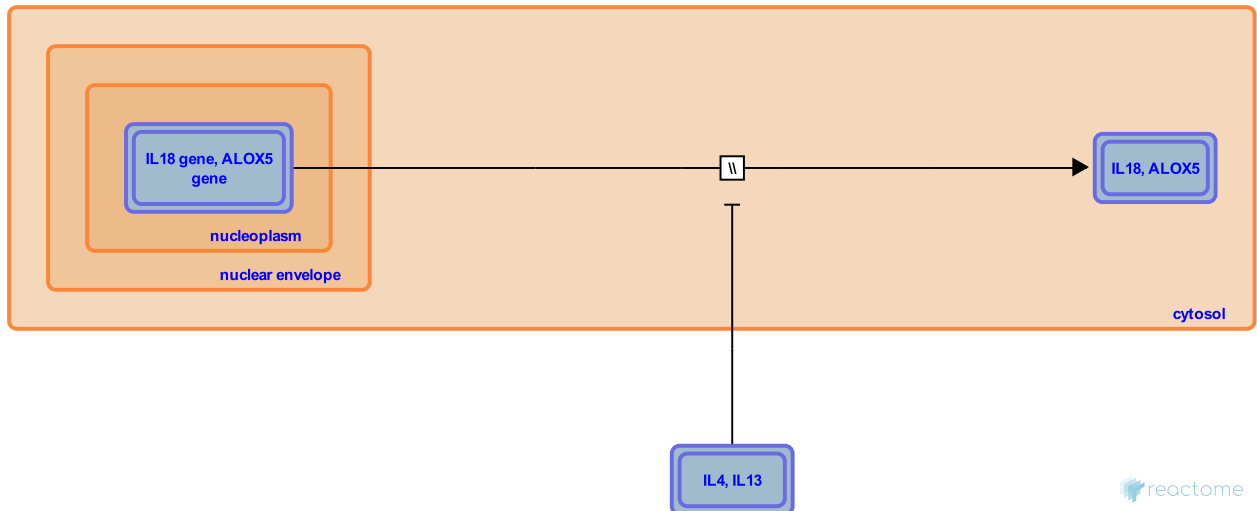

In human peripheral blood, monocytes Interleukin-4 (IL4) and Interleukin-13 significantly downregulate the expression of classical proinflammatory signal transducers, such as Interleukin-1 (IL1), Interleukin-6, Interleukin-8, Interleukin-18, C-C motif chemokine 2 (CCL2) and Tumor necrosis factor (TNF). Expression of Prostaglandin G/H synthase 2 (PTGS2, COX2) and Arachidonate 5-lipoxygenase (ALOX5), enzymes involved in the biosynthesis of the proinflammatory eicosanoids, is also attenuated (Chatidis et al. 2005).

This is a black box event because the mechanism of gene regulation is not fully defined.

Literature references

Chatidis, P., O'Donnell, V., Kuban, RJ., Bermudez-Fajardo, A., Ungethuen, U., Kühn, H. (2005). Gene expression alterations of human peripheral blood monocytes induced by medium-term treatment with the TH2-cytokines interleukin-4 and -13. *Cytokine*, 30, 366-77. ↗

Editions

2015-07-01	Authored	Jupe, S.
2016-09-02	Edited	Jupe, S.
2016-09-02	Reviewed	Leibovich, SJ.

Expression of IL13-upregulated plasma membrane proteins ↗

Location: [Interleukin-4 and Interleukin-13 signaling](#)

Stable identifier: R-HSA-6788346

Type: omitted

Compartments: nucleoplasm, plasma membrane

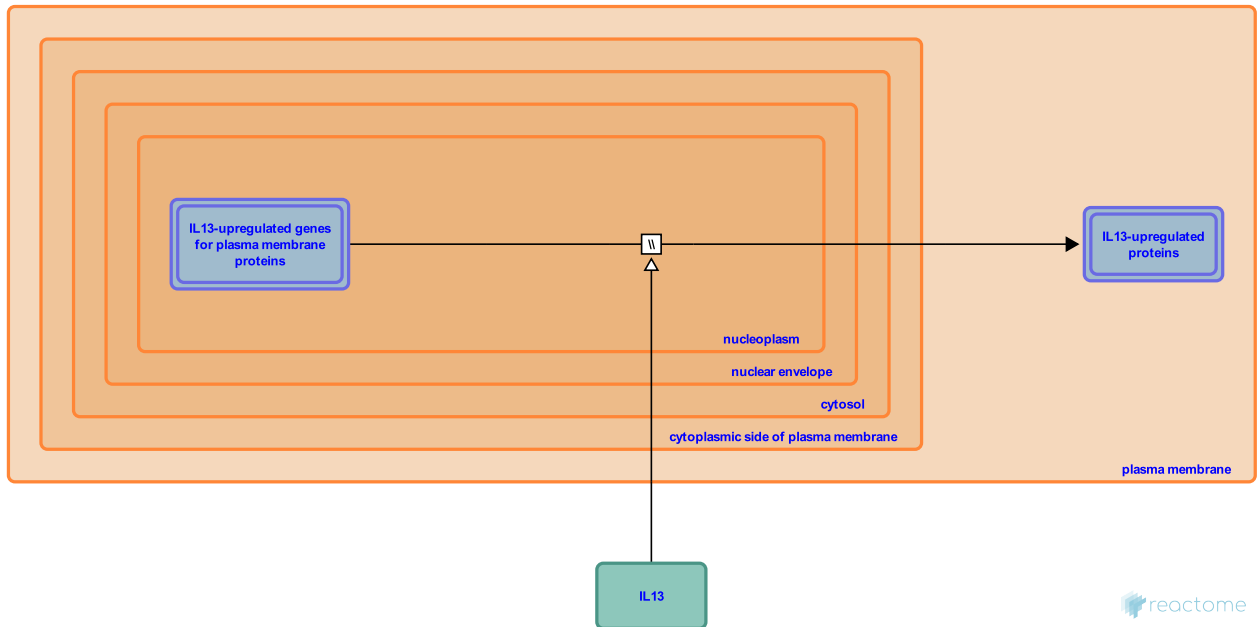

In monocytes and macrophages Interleukin-13 (IL13) enhances the expression of many members of the integrin family including Integrin alpha M (ITGAM, CD11b), Integrin alpha-X (ITGAX, CD11c), Integrin beta 2 (ITGB2, CD18) and Integrin beta 1 (ITGB1, CD29) (Zurawski & de Vries 1994), MHC class II and low affinity immunoglobulin epsilon Fc receptor (FCER2, CD23) expression (de Vries 1998). In endothelial cells IL13 induces expression of Vascular cell adhesion protein 1 (VCAM1), which is important in the recruitment of eosinophils (Bochner et al. 1995).

Preceded by: [p-Y-STATs translocate to nucleus](#)

Literature references

- Zurawski, G., de Vries, JE. (1994). Interleukin 13, an interleukin 4-like cytokine that acts on monocytes and B cells, but not on T cells. *Immunol. Today*, 15, 19-26. ↗
- de Vries, JE. (1998). The role of IL-13 and its receptor in allergy and inflammatory responses. *J. Allergy Clin. Immunol.*, 102, 165-9. ↗
- Bochner, BS., Klunk, DA., Sterbinsky, SA., Coffman, RL., Schleimer, RP. (1995). IL-13 selectively induces vascular cell adhesion molecule-1 expression in human endothelial cells. *J. Immunol.*, 154, 799-803. ↗

Editions

2015-07-01	Authored	Jupe, S.
2016-09-02	Edited	Jupe, S.
2016-09-02	Reviewed	Leibovich, SJ.

Expression of IL13-downregulated extracellular proteins ↗

Location: [Interleukin-4 and Interleukin-13 signaling](#)

Stable identifier: R-HSA-6789325

Type: omitted

Compartments: extracellular region, nucleoplasm

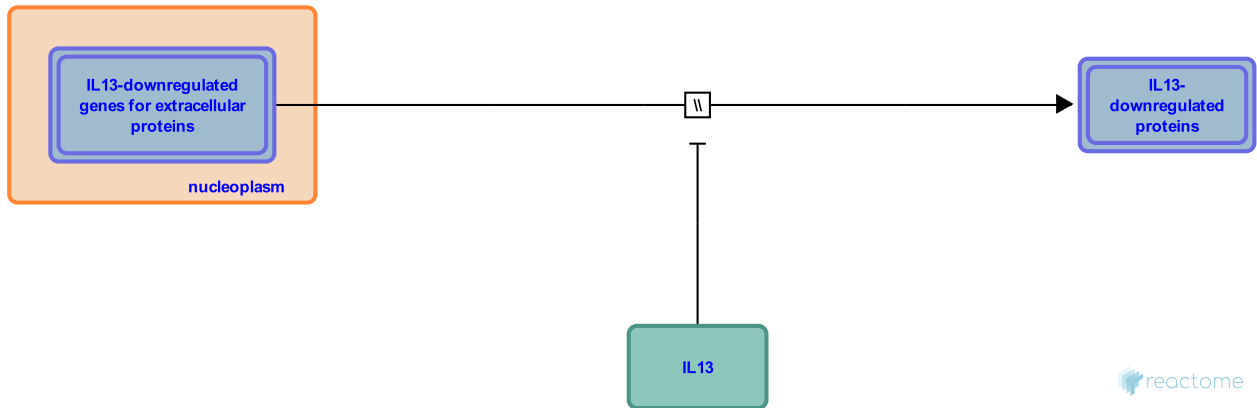

IL13 inhibits monocyte and macrophage production of Interleukin-1 (IL1), IL6, IL8, Tumor necrosis factor (TNF) and IL12 (de Vries et al. 1998), through a mechanism that partially involves suppression of Nuclear factor NF-kappa-B.

Literature references

de Vries, JE. (1998). The role of IL-13 and its receptor in allergy and inflammatory responses. *J. Allergy Clin. Immunol.*, 102, 165-9. ↗

Editions

2015-07-01	Authored	Jupe, S.
2016-09-02	Edited	Jupe, S.
2016-09-02	Reviewed	Leibovich, SJ.

Table of Contents

Introduction	1
🔌 Interleukin-4 and Interleukin-13 signaling	2
➤ IL4R binds JAK2	4
➤ IL2RG binds JAK3	5
➤ JAK3 binds JAK3 inhibitors	6
➤ IL13RA1 binds TYK2	7
➤ IL4 binds IL4R:JAK2	8
➤ IL4:IL4R:JAK2 binds IL2RG:JAK3	9
➤ IL4:IL4R:JAK2 binds IL13RA1:TYK2	10
↔ JAK1 binds IL4R in IL4-bound IL4R1	11
↔ IL4R, IL2RG, JAK1 in IL4-bound IL4R1:JAK1 are phosphorylated	12
➤ STAT3,STAT6 bind p-Y-IL4R	13
➤ JAK1 phosphorylates STAT3,STAT6	15
↔ p-Y705-STAT3,p-Y641-STAT6 dissociate	16
↔ p-Y705-STAT3, p-Y641-STAT6 dimerise	17
↔ p-Y705-STAT3 dimer, p-Y641-STAT6 dimer translocate to nucleus	18
↔ Expression of SOCS1	19
↔ Expression of GATA3	20
↔ Expression of STAT6-upregulated extracellular proteins	21
↔ Expression of STAT6-upregulated plasma membrane proteins	22
↔ Expression of STAT3-upregulated extracellular proteins	24
↔ Expression of STAT3-upregulated plasma membrane proteins	26
↔ Expression of STAT3-upregulated cytosolic proteins	28
↔ Expression of STAT3-upregulated nuclear proteins	30
↔ Expression of BCL2, BCL2L1	32
↔ Expression of HSP90B1	33
↔ Expression of PTGS2	34
↔ Expression of NDN,TP53	35
↔ Expression of FASLG	36
➤ SOCS5,(SOCS1) bind IL4RA	37
➤ IL13 binds IL13RA2	38
➤ IL13 binds IL13RA:TYK2	39
➤ IL13:IL13RA:TYK2 binds IL4R:JAK2	40
↔ JAK1 binds IL4R in IL13-bound IL13R type II	41

IL4R, IL13RA, JAK2 and TYK2 are tyrosine phosphorylated	42
STAT1,STAT3,STAT6 bind IL13:IL13R type II	43
STAT1,STAT3,STAT6 phosphorylation	45
p-Y-STATs dissociate	46
p-Y-STATs dimerize	47
p-Y-STATs translocate to nucleus	48
Expression of IL4, IL13-upregulated extracellular proteins	49
Expression of HSPA8, ALOX15	50
Expression of CD36	51
Expression of HMOX1	52
Expression of MAOA	53
Expression of IL4,IL13-downregulated extracellular genes	54
Expression of IL18, ALOX5	55
Expression of IL13-upregulated plasma membrane proteins	56
Expression of IL13-downregulated extracellular proteins	57
Table of Contents	58