

# Activation of NIMA Kinases NEK9, NEK6, NEK7

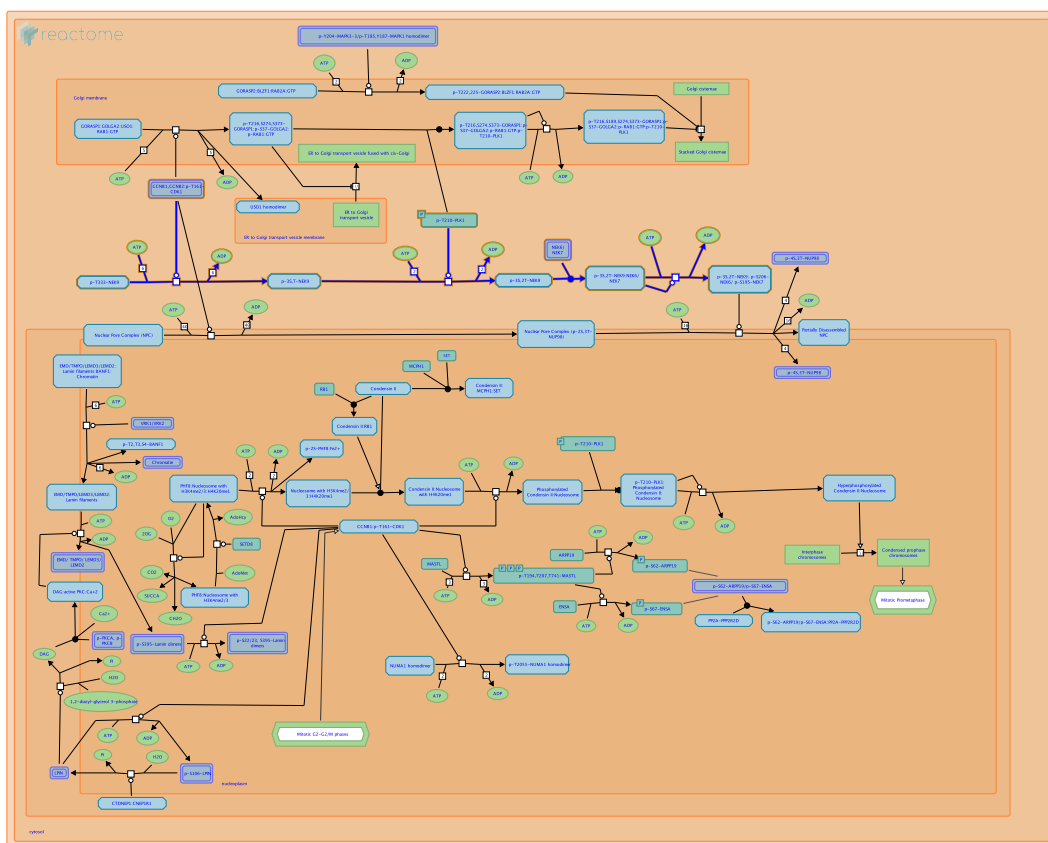

Avruch, J., Gillespie, ME., Orlic-Milacic, M.

European Bioinformatics Institute, New York University Langone Medical Center, Ontario Institute for Cancer Research, Oregon Health and Science University.

The contents of this document may be freely copied and distributed in any media, provided the authors, plus the institutions, are credited, as stated under the terms of [Creative Commons Attribution 4.0 International \(CC BY 4.0\) License](https://creativecommons.org/licenses/by/4.0/). For more information see our [license](https://creativecommons.org/licenses/by/4.0/).

## Introduction

Reactome is open-source, open access, manually curated and peer-reviewed pathway database. Pathway annotations are authored by expert biologists, in collaboration with Reactome editorial staff and cross-referenced to many bioinformatics databases. A system of evidence tracking ensures that all assertions are backed up by the primary literature. Reactome is used by clinicians, geneticists, genomics researchers, and molecular biologists to interpret the results of high-throughput experimental studies, by bioinformaticians seeking to develop novel algorithms for mining knowledge from genomic studies, and by systems biologists building predictive models of normal and disease variant pathways.

The development of Reactome is supported by grants from the US National Institutes of Health (P41 HG003751), University of Toronto (CFREF Medicine by Design), European Union (EU STRP, EMI-CD), and the European Molecular Biology Laboratory (EBI Industry program).

## Literature references

- Fabregat, A., Sidiropoulos, K., Viteri, G., Forner, O., Marin-Garcia, P., Arnau, V. et al. (2017). Reactome pathway analysis: a high-performance in-memory approach. *BMC bioinformatics*, 18, 142. [↗](#)
- Sidiropoulos, K., Viteri, G., Sevilla, C., Jupe, S., Webber, M., Orlic-Milacic, M. et al. (2017). Reactome enhanced pathway visualization. *Bioinformatics*, 33, 3461-3467. [↗](#)
- Fabregat, A., Jupe, S., Matthews, L., Sidiropoulos, K., Gillespie, M., Garapati, P. et al. (2018). The Reactome Pathway Knowledgebase. *Nucleic Acids Res*, 46, D649-D655. [↗](#)
- Fabregat, A., Korninger, F., Viteri, G., Sidiropoulos, K., Marin-Garcia, P., Ping, P. et al. (2018). Reactome graph database: Efficient access to complex pathway data. *PLoS computational biology*, 14, e1005968. [↗](#)

Reactome database release: 77

This document contains 1 pathway and 4 reactions ([see Table of Contents](#))

# Activation of NIMA Kinases NEK9, NEK6, NEK7 ↗

Stable identifier: R-HSA-2980767

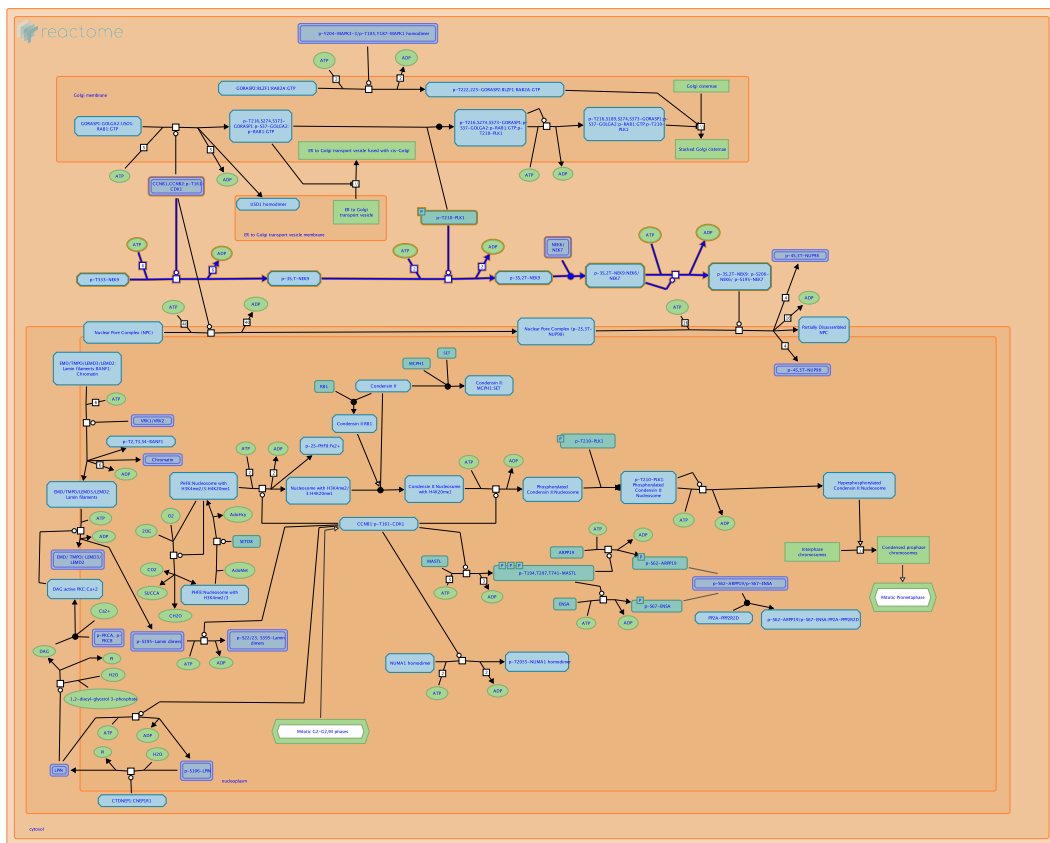

NEK6 and NEK7 are activated during mitosis by another NIMA family kinase, NEK9 (Belham et al. 2003, Richards et al. 2009), which is activated by CDK1- and PLK1-mediated phosphorylation (Roig et al. 2002, Bertran et al. 2011).

## Literature references

Belham, C., Roig, J., Caldwell, JA., Aoyama, Y., Kemp, BE., Comb, M. et al. (2003). A mitotic cascade of NIMA family kinases. Nerccl1/Nek9 activates the Nek6 and Nek7 kinases. *J. Biol. Chem.*, 278, 34897-909. ↗

Roig, J., Mikhailov, A., Belham, C., Avruch, J. (2002). Nerccl1, a mammalian NIMA-family kinase, binds the Ran GT-Pase and regulates mitotic progression. *Genes Dev.*, 16, 1640-58. ↗

Bertran, MT., Sdelci, S., Regué, L., Avruch, J., Caelles, C., Roig, J. (2011). Nek9 is a Plk1-activated kinase that controls early centrosome separation through Nek6/7 and Eg5. *EMBO J.*, 30, 2634-47. ↗

Richards, MW., O'Regan, L., Mas-Droux, C., Blot, JM., Cheung, J., Hoelder, S. et al. (2009). An autoinhibitory tyrosine motif in the cell-cycle-regulated Nek7 kinase is released through binding of Nek9. *Mol. Cell*, 36, 560-70. ↗

## Editions

2013-01-22	Authored	Orlic-Milacic, M.
2013-02-08	Reviewed	Avruch, J.

## CDK1:CCNB phosphorylates NEK9 ↗

**Location:** [Activation of NIMA Kinases NEK9, NEK6, NEK7](#)

**Stable identifier:** R-HSA-2984220

**Type:** transition

**Compartments:** cytosol

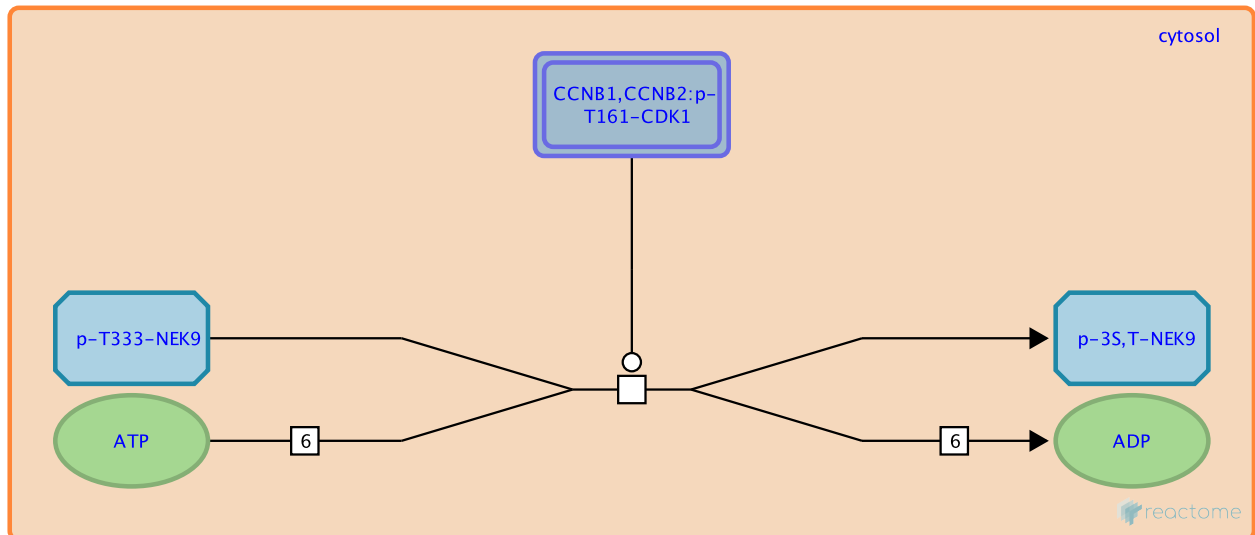

NEK9 functions as a homodimer and becomes catalytically active in mitosis through phosphorylation (Roig et al. 2002). While threonine T333 of NEK9 is phosphorylated in both interphase and mitotic cells (Roig et al. 2005, Bertran et al. 2011), serine residues S29, S750 and S869 of NEK9 are phosphorylated only in mitotic cells. S29, S750 and S869 sites are proline directed and match the CDK1 consensus sequence (Bertran et al. 2011). CDK1:CCNB complex was shown to phosphorylate NEK9 in vitro (Roig et al. 2002).

**Followed by:** [PLK1 phosphorylates NEK9](#)

### Literature references

- Roig, J., Mikhailov, A., Belham, C., Avruch, J. (2002). Nercc1, a mammalian NIMA-family kinase, binds the Ran GT-Pase and regulates mitotic progression. *Genes Dev.*, 16, 1640-58. ↗
- Bertran, MT., Sdelci, S., Regué, L., Avruch, J., Caelles, C., Roig, J. (2011). Nek9 is a Plk1-activated kinase that controls early centrosome separation through Nek6/7 and Eg5. *EMBO J.*, 30, 2634-47. ↗
- Roig, J., Groen, A., Caldwell, J., Avruch, J. (2005). Active Nercc1 protein kinase concentrates at centrosomes early in mitosis and is necessary for proper spindle assembly. *Mol. Biol. Cell*, 16, 4827-40. ↗

### Editions

2013-01-22	Authored	Orlic-Milacic, M.
2013-01-23	Edited	Gillespie, ME.
2013-02-08	Reviewed	Avruch, J.

## PLK1 phosphorylates NEK9 ↗

**Location:** [Activation of NIMA Kinases NEK9, NEK6, NEK7](#)

**Stable identifier:** R-HSA-2984226

**Type:** transition

**Compartments:** cytosol

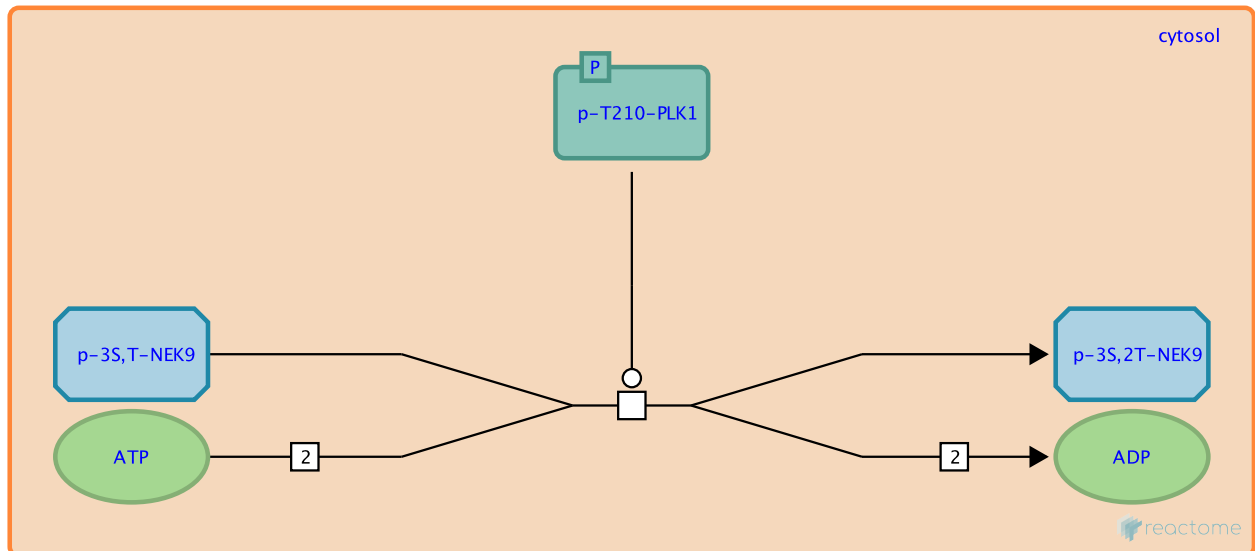

NEK9 serine residues S29, S750 and S869, which are likely targets of CDK1:CCNB-mediated phosphorylation in mitosis, can be recognized by the polo-box domain (PBD) of PLK1 when phosphorylated. Phosphorylation of S869 appears to be crucial for the interaction of NEK9 and PLK1 (Bertran et al. 2011). PLK1 phosphorylates threonine T210 of NEK9 in vitro. T210 is located in the kinase activation loop of NEK9 and T210 phosphorylation is necessary for NEK9 kinase activity. While T210 can be autophosphorylated in vitro, when NEK9 is incubated in the presence of excess ATP and Mg<sup>2+</sup> (Roig et al. 2005), mitotic phosphorylation of T210 requires both CDK1 and PLK1 activity (Bertran et al. 2011).

**Preceded by:** [CDK1:CCNB phosphorylates NEK9](#)

**Followed by:** [NEK9 binds NEK6/NEK7 in the cytosol](#)

### Literature references

Bertran, MT., Sdelci, S., Regué, L., Avruch, J., Caelles, C., Roig, J. (2011). Nek9 is a Plk1-activated kinase that controls early centrosome separation through Nek6/7 and Eg5. *EMBO J.*, 30, 2634-47. ↗

Roig, J., Groen, A., Caldwell, J., Avruch, J. (2005). Active Nerccl protein kinase concentrates at centrosomes early in mitosis and is necessary for proper spindle assembly. *Mol. Biol. Cell*, 16, 4827-40. ↗

### Editions

2013-01-22	Authored	Orlic-Milacic, M.
2013-01-23	Edited	Gillespie, ME.
2013-02-08	Reviewed	Avruch, J.

## NEK9 binds NEK6/NEK7 in the cytosol ↗

**Location:** [Activation of NIMA Kinases NEK9, NEK6, NEK7](#)

**Stable identifier:** R-HSA-2980720

**Type:** binding

**Compartments:** cytosol

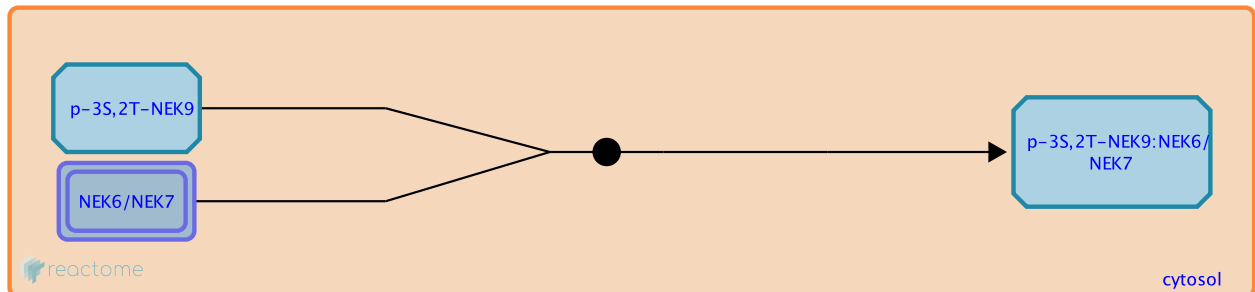

NEK9 forms a tight complex with NEK6 or NEK7 (Roig et al. 2002, Belham et al. 2003) in the cytosol.

**Preceded by:** [PLK1 phosphorylates NEK9](#)

**Followed by:** [NEK9 phosphorylates NEK6/NEK7](#)

### Literature references

Roig, J., Mikhailov, A., Belham, C., Avruch, J. (2002). Nercc1, a mammalian NIMA-family kinase, binds the Ran GT-Pase and regulates mitotic progression. *Genes Dev.*, 16, 1640-58. ↗

Belham, C., Roig, J., Caldwell, JA., Aoyama, Y., Kemp, BE., Comb, M. et al. (2003). A mitotic cascade of NIMA family kinases. Nercc1/Nek9 activates the Nek6 and Nek7 kinases. *J. Biol. Chem.*, 278, 34897-909. ↗

### Editions

2013-01-22	Authored	Orlic-Milacic, M.
2013-01-23	Edited	Gillespie, ME.
2013-02-08	Reviewed	Avruch, J.

## NEK9 phosphorylates NEK6/NEK7 ↗

**Location:** [Activation of NIMA Kinases NEK9, NEK6, NEK7](#)

**Stable identifier:** R-HSA-2984258

**Type:** transition

**Compartments:** cytosol

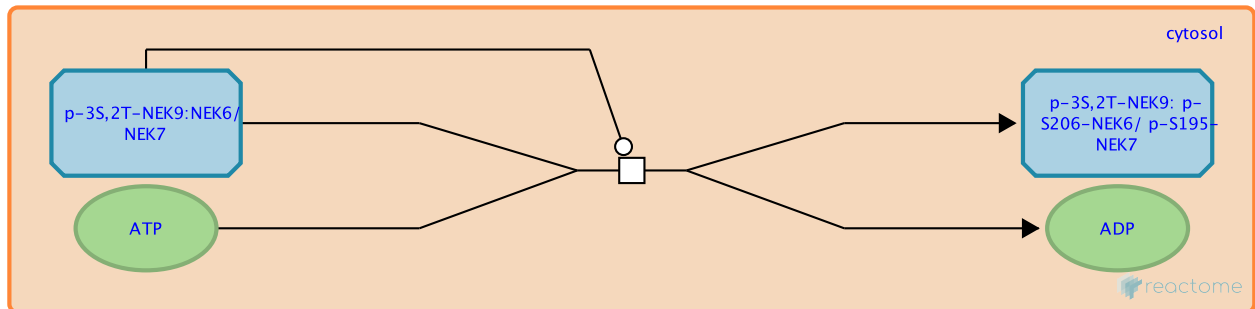

NEK9, activated by CDK1- and PLK1-mediated phosphorylation, phosphorylates NEK6 on serine residue S206, and NEK7 on serine residue S195. S206 and S195 are located in the activation loop of NEK6 and NEK7, respectively. NEK6 activation is dependent on S206 phosphorylation, although phosphorylation at threonine T202 may augment NEK6 kinase activity. NEK7 activity also depends on phosphorylation of S195. NEK9 remains tightly associated with NEK6 (as well as NEK7) after phosphorylation, and may direct NEK6/NEK7 to specific target (Belham et al. 2003). In addition, irrespective of phosphorylation, binding of the non-catalytic C-terminus of NEK9 to NEK7 (as well as NEK6), relieves autoinhibitory conformation of NEK7/NEK6. The autoinhibitory conformation of NEK7 depends on the formation of a hydrogen bond between tyrosine Y97 (tyrosine Y108 in NEK6) and leucine L180. This Y97-involving hydrogen bond prevents the formation of a salt bridge between lysine K63 and glutamate E82 of NEK7, which is essential for catalysis. Binding of NEK9 is thought to disrupt the hydrogen bond between Y97 and L180 of NEK7 (Y108 and L191 of NEK6) and allow NEK7/NEK6 to achieve active conformation (Richards et al. 2009).

**Preceded by:** [NEK9 binds NEK6/NEK7 in the cytosol](#)

### Literature references

Belham, C., Roig, J., Caldwell, JA., Aoyama, Y., Kemp, BE., Comb, M. et al. (2003). A mitotic cascade of NIMA family kinases. Nerccl1/Nek9 activates the Nek6 and Nek7 kinases. *J. Biol. Chem.*, 278, 34897-909. ↗

Richards, MW., O'Regan, L., Mas-Droux, C., Blot, JM., Cheung, J., Hoelder, S. et al. (2009). An autoinhibitory tyrosine motif in the cell-cycle-regulated Nek7 kinase is released through binding of Nek9. *Mol. Cell*, 36, 560-70. ↗

### Editions

2013-01-22	Authored	Orlic-Milacic, M.
2013-01-23	Edited	Gillespie, ME.
2013-02-08	Reviewed	Avruch, J.

# Table of Contents

Introduction	1
☰ Activation of NIMA Kinases NEK9, NEK6, NEK7	2
➤ CDK1:CCNB phosphorylates NEK9	3
➤ PLK1 phosphorylates NEK9	4
➤ NEK9 binds NEK6/NEK7 in the cytosol	5
➤ NEK9 phosphorylates NEK6/NEK7	6
Table of Contents	7