

# Senescence-Associated Secretory Phenotype (SASP)

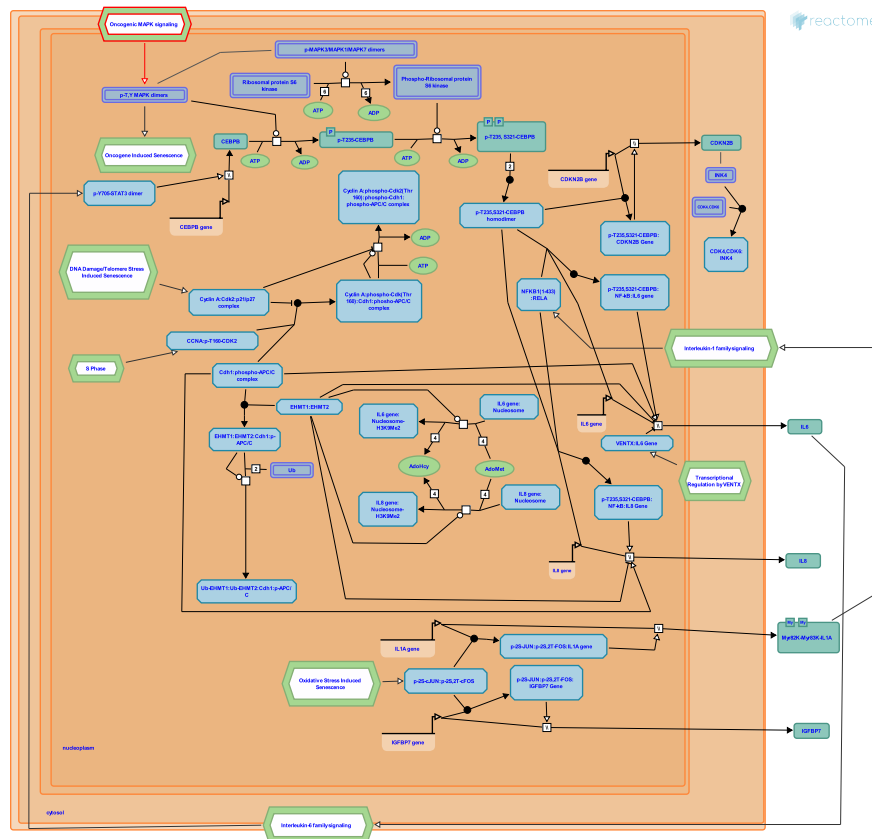

Annibali, D., Bennett, DC., D'Eustachio, P., Greene, LA., Matthews, L., Nasi, S., Orlic-Milacic, M., Roger, PP., Samarajiwa, S., Vegi, NM.

European Bioinformatics Institute, New York University Langone Medical Center, Ontario Institute for Cancer Research, Oregon Health and Science University.

The contents of this document may be freely copied and distributed in any media, provided the authors, plus the institutions, are credited, as stated under the terms of [Creative Commons Attribution 4.0 International \(CC BY 4.0\) License](https://creativecommons.org/licenses/by/4.0/). For more information see our [license](https://reactome.org/licenses/).

This is just an excerpt of a full-length report for this pathway. To access the complete report, please download it at the [Reactome Textbook](https://reactome.org/textbook/).

30/04/2024

## Introduction

Reactome is open-source, open access, manually curated and peer-reviewed pathway database. Pathway annotations are authored by expert biologists, in collaboration with Reactome editorial staff and cross-referenced to many bioinformatics databases. A system of evidence tracking ensures that all assertions are backed up by the primary literature. Reactome is used by clinicians, geneticists, genomics researchers, and molecular biologists to interpret the results of high-throughput experimental studies, by bioinformaticians seeking to develop novel algorithms for mining knowledge from genomic studies, and by systems biologists building predictive models of normal and disease variant pathways.

The development of Reactome is supported by grants from the US National Institutes of Health (P41 HG003751), University of Toronto (CFREF Medicine by Design), European Union (EU STRP, EMI-CD), and the European Molecular Biology Laboratory (EBI Industry program).

## Literature references

- Fabregat, A., Sidiropoulos, K., Viteri, G., Forner, O., Marin-Garcia, P., Arnau, V. et al. (2017). Reactome pathway analysis: a high-performance in-memory approach. *BMC bioinformatics*, 18, 142. [↗](#)
- Sidiropoulos, K., Viteri, G., Sevilla, C., Jupe, S., Webber, M., Orlic-Milacic, M. et al. (2017). Reactome enhanced pathway visualization. *Bioinformatics*, 33, 3461-3467. [↗](#)
- Fabregat, A., Jupe, S., Matthews, L., Sidiropoulos, K., Gillespie, M., Garapati, P. et al. (2018). The Reactome Pathway Knowledgebase. *Nucleic Acids Res*, 46, D649-D655. [↗](#)
- Fabregat, A., Korninger, F., Viteri, G., Sidiropoulos, K., Marin-Garcia, P., Ping, P. et al. (2018). Reactome graph database: Efficient access to complex pathway data. *PLoS computational biology*, 14, e1005968. [↗](#)

Reactome database release: 88

This document contains 1 pathway and 22 reactions ([see Table of Contents](#))

# Senescence-Associated Secretory Phenotype (SASP) ↗

Stable identifier: R-HSA-2559582

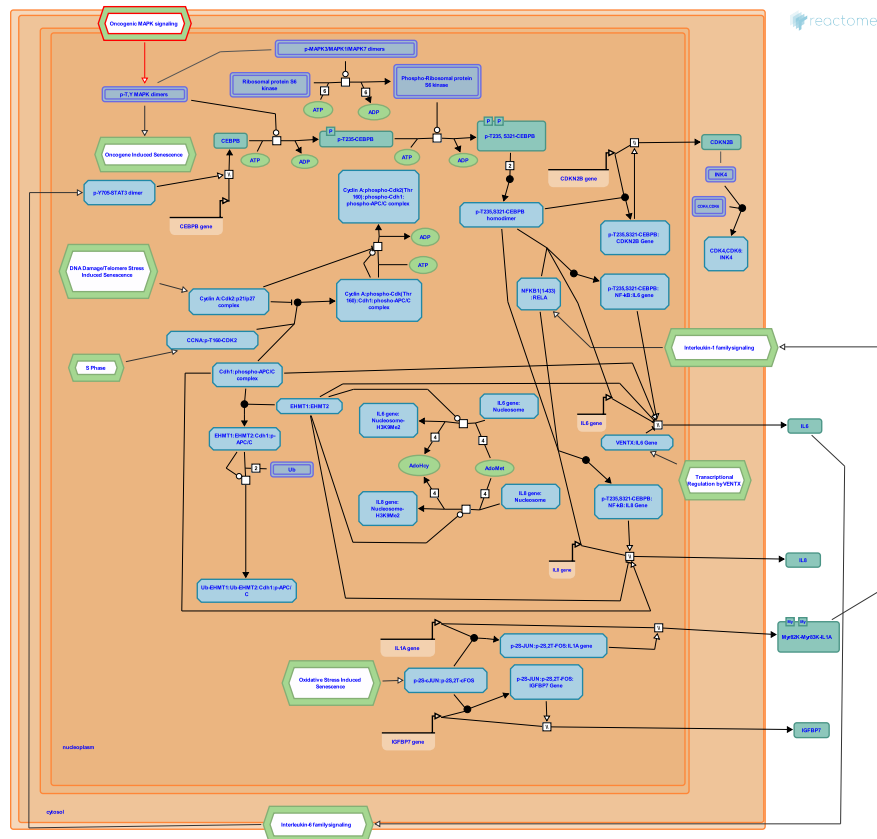

The culture medium of senescent cells is enriched in secreted proteins when compared with the culture medium of quiescent i.e. presenescent cells and these secreted proteins constitute the so-called senescence-associated secretory phenotype (SASP), also known as the senescence messaging secretome (SMS). SASP components include inflammatory and immune-modulatory cytokines (e.g. IL6 and IL8), growth factors (e.g. IGF1), shed cell surface molecules (e.g. TNF receptors) and survival factors. While the SASP exhibits a wide ranging profile, it is not significantly affected by the type of senescence trigger (oncogenic signalling, oxidative stress or DNA damage) or the cell type (epithelial vs. mesenchymal) (Coppe et al. 2008). However, as both oxidative stress and oncogenic signaling induce DNA damage, the persistent DNA damage may be a deciding SASP initiator (Rodier et al. 2009). SASP components function in an autocrine manner, reinforcing the senescent phenotype (Kuilman et al. 2008, Acosta et al. 2008), and in the paracrine manner, where they may promote epithelial-to-mesenchymal transition (EMT) and malignancy in the nearby premalignant or malignant cells (Coppe et al. 2008). Interleukin-1-alpha (IL1A), a minor SASP component whose transcription is stimulated by the AP-1 (FOS:JUN) complex (Bailey et al. 1996), can cause paracrine senescence through IL1 and inflammasome signaling (Acosta et al. 2013).

Here, transcriptional regulatory processes that mediate the SASP are annotated. DNA damage triggers ATM-mediated activation of TP53, resulting in the increased level of CDKN1A (p21). CDKN1A-mediated inhibition of CDK2 prevents phosphorylation and inactivation of the Cdh1:APC/C complex, allowing it to ubiquitinate and target for degradation EHMT1 and EHMT2 histone methyltransferases. As EHMT1 and EHMT2 methylate and silence the promoters of IL6 and IL8 genes, degradation of these methyltransferases relieves the inhibition of IL6 and IL8 transcription (Takahashi et al. 2012). In addition, oncogenic RAS signaling activates the CEBPB (C/EBP-beta) transcription factor (Nakajima et al. 1993, Lee et al. 2010), which binds promoters of IL6 and IL8 genes and stimulates their transcription (Kuilman et al. 2008, Lee et al. 2010). CEBPB also stimulates the transcription of CDKN2B (p15-INK4B), reinforcing the cell cycle arrest (Kuilman et al. 2008). CEBPB transcription factor has three isoforms, due to three alternative translation start sites. The CEBPB-1 isoform (C/EBP-beta-1) seems to be exclusively involved in growth arrest and senescence, while the CEBPB-2 (C/EBP-beta-2) isoform may promote cellular proliferation (Atwood and Sealy 2010 and 2011). IL6 signaling stimulates the transcription of CEBPB (Niehof et al. 2001), creating a positive feedback loop (Kuilman et al. 2009, Lee et al. 2010). NF-kappa-B transcription factor is also activated in senescence (Chien et al. 2011) through IL1 signaling (Jimi et al. 1996, Hartupée et al. 2008, Orjalo et al. 2009). NF-kappa-B binds IL6 and IL8 promoters and cooperates with CEBPB transcription factor in the induction of IL6 and IL8 transcription (Matsusaka et al. 1993, Acosta et al. 2008). Besides IL6 and IL8, their receptors are also upregulated in senescence (Kuilman et al. 2008, Acosta et al. 2008) and IL6 and

IL8 may be master regulators of the SASP.

IGFBP7 is also an SASP component that is upregulated in response to oncogenic RAS-RAF-MAPK signaling and oxidative stress, as its transcription is directly stimulated by the AP-1 (JUN:FOS) transcription factor. IGFBP7 negatively regulates RAS-RAF (BRAF)-MAPK signaling and is important for the establishment of senescence in melanocytes (Wajapeyee et al. 2008).

Please refer to Young and Narita 2009 for a recent review.

## Literature references

Shuman, JD., Cohen, MS., Sakchaisri, K., Taunton, J., Lee, S., Sebastian, T. et al. (2010). RSK-mediated phosphorylation in the C/EBP $\beta$  leucine zipper regulates DNA binding, dimerization, and growth arrest activity. *Mol. Cell Biol.*, 30, 2621-35. [↗](#)

Koga, T., Suda, T., Hirata, M., Takahashi, N., Jimi, E., Ikebe, T. (1996). Interleukin-1 alpha activates an NF-kappaB-like factor in osteoclast-like cells. *J. Biol. Chem.*, 271, 4605-8. [↗](#)

Sealy, LJ., Atwood, AA. (2011). C/EBP $\beta$ 's role in determining Ras-induced senescence or transformation. *Small GTPases*, 2, 41-46. [↗](#)

Capper, D., Benitah, SA., Snijders, AP., Jin, H., Khan, S., Morton, JP. et al. (2013). A complex secretory program orchestrated by the inflammasome controls paracrine senescence. *Nat. Cell Biol.*, 15, 978-90. [↗](#)

Raguz, S., Bernard, D., Gil, J., Da Costa, M., Fumagalli, M., O'Loughlen, A. et al. (2008). Chemokine signaling via the CXCR2 receptor reinforces senescence. *Cell*, 133, 1006-18. [↗](#)

## Editions

2013-07-15	Edited	D'Eustachio, P., Matthews, L.
2013-07-15	Authored	Orlic-Milacic, M.
2013-09-03	Reviewed	Samarajiwa, S.
2013-09-30	Revised	Orlic-Milacic, M.

## CDKN1A (p21) prevents association of Cyclin A:Cdk2 with Cdh1 ↗

**Location:** Senescence-Associated Secretory Phenotype (SASP)

**Stable identifier:** R-HSA-3788708

**Type:** binding

**Compartments:** nucleoplasm

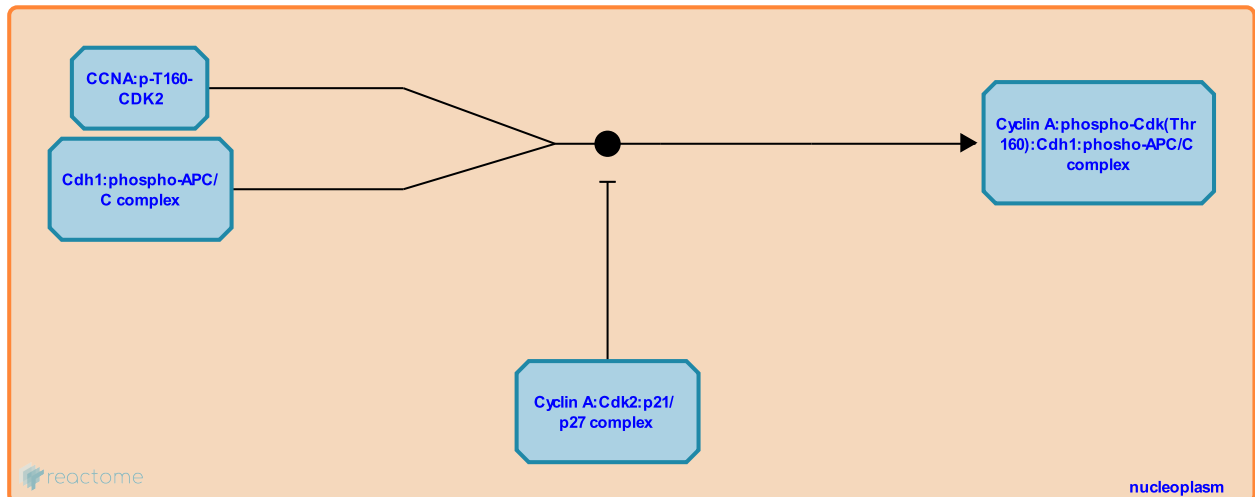

Cyclin A-Cdk2 (CCNA:CDK2) prevents unscheduled APC reactivation during S phase by binding and subsequently phosphorylating FZR1 (Cdh1). Phosphorylation-dependent dissociation of the Cdh1-activating subunit inhibits the APC/C (Sorensen et al. 2001). DNA damage activates ATM kinase, resulting in TP53-mediated induction of CDKN1A (p21) expression. CDKN1A binds CCNA:CDK2 complex and prevents its association with Cdh1 (Takahashi et al. 2012).

**Followed by:** [CDKN1A \(p21\) prevents phosphorylation of Cdh1 by Cyclin A:Cdk2](#)

### Literature references

Lukas, J., Peters, JM., Kramer, ER., Sorensen, CS., Lukas, C. (2001). A conserved cyclin-binding domain determines functional interplay between anaphase-promoting complex-Cdh1 and cyclin A-Cdk2 during cell cycle progression. *Mol Cell Biol*, 21, 3692-703. ↗

Peters, G., Yoshimoto, S., Shinkai, Y., Imai, Y., Tachibana, M., Takahashi, A. et al. (2012). DNA damage signaling triggers degradation of histone methyltransferases through APC/C(Cdh1) in senescent cells. *Mol. Cell*, 45, 123-31. ↗

### Editions

2013-07-15	Edited	D'Eustachio, P., Matthews, L.
2013-07-15	Authored	Orlic-Milacic, M.
2013-09-03	Reviewed	Samarajiwa, S.

## CDKN1A (p21) prevents phosphorylation of Cdh1 by Cyclin A:Cdk2 ↗

**Location:** Senescence-Associated Secretory Phenotype (SASP)

**Stable identifier:** R-HSA-3788705

**Type:** transition

**Compartments:** nucleoplasm

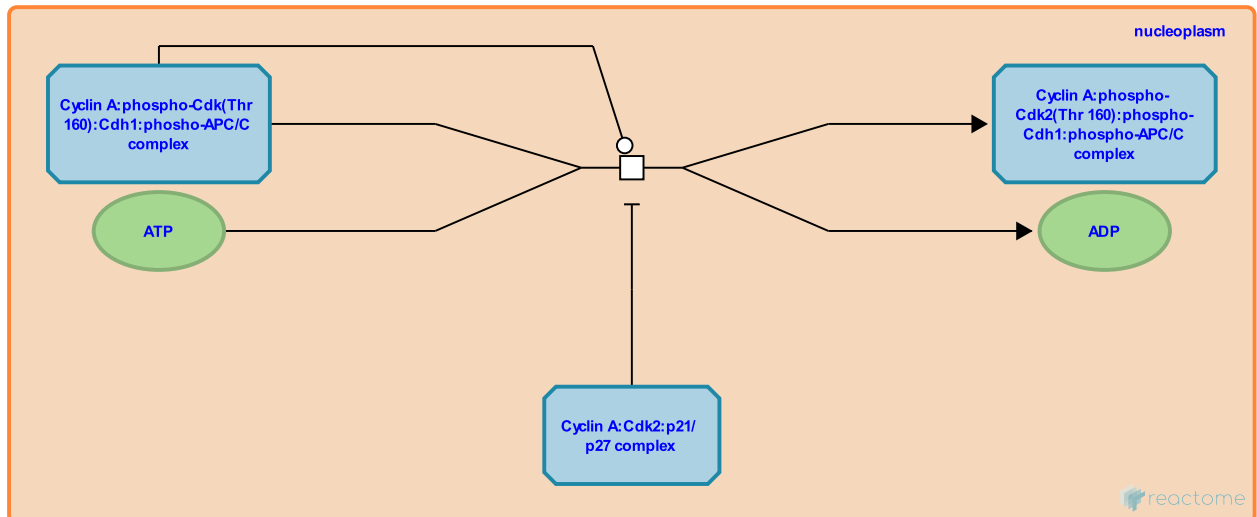

At the G1/S transition, the Cdh1 (FZR1) subunit of the APC/C:Cdh1 complex is phosphorylated by Cyclin A:Cdk2 (CCNA:CDK2) and dissociates from APC/C. This inactivates APC/C and permits the accumulation of cell cycle proteins required for DNA synthesis and entry into mitosis (Lukas et al. 1999). Activation of the ATM kinase by DNA damage in the form of double strand breaks results in TP53-mediated induction of CDKN1A (p21) expression. CDKN1A binds CCNA:CDK2 complex and prevents it from phosphorylating Cdh1 (Takahashi et al. 2012).

**Preceded by:** [CDKN1A \(p21\) prevents association of Cyclin A:Cdk2 with Cdh1](#)

### Literature references

Peters, G., Yoshimoto, S., Shinkai, Y., Imai, Y., Tachibana, M., Takahashi, A. et al. (2012). DNA damage signaling triggers degradation of histone methyltransferases through APC/C(Cdh1) in senescent cells. *Mol. Cell*, 45, 123-31. ↗

Lukas, J., Lindene, C., Peters, JM., Sorensen, CS., Kramer, E., Lukas, C. et al. (1999). Accumulation of cyclin B1 requires E2F and cyclin-A-dependent rearrangement of the anaphase-promoting complex. *Nature*, 401, 815-8. ↗

### Editions

2013-07-15	Edited	D'Eustachio, P., Matthews, L.
2013-07-15	Authored	Orlic-Milacic, M.
2013-09-03	Reviewed	Samarajiwa, S.

## Cdh1:APC/C complex binds EHMT1:EHMT2 ↗

**Location:** Senescence-Associated Secretory Phenotype (SASP)

**Stable identifier:** R-HSA-3788725

**Type:** binding

**Compartments:** nucleoplasm

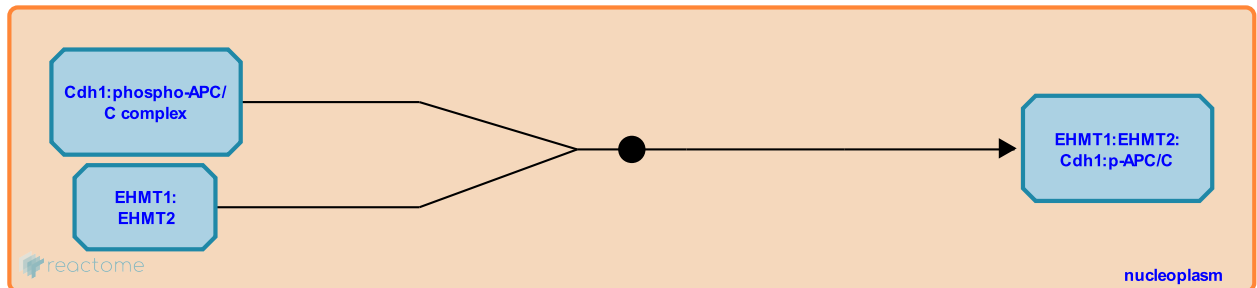

Cdh1 (FZR1) is able to bind both G9a (EHMT2) and GLP (EHMT1) (Takahashi et al. 2012). EHMT1 and EHMT2 histone methyltransferases were shown to function as a heterodimer in vivo (Tachibana et al. 2005).

**Followed by:** Cdh1:APC/C ubiquitinates EHMT1 and EHMT2

### Literature references

Iwanari, H., Shinkai, Y., Hamakubo, T., Ohta, T., Fukuda, M., Tachibana, M. et al. (2005). Histone methyltransferases G9a and GLP form heteromeric complexes and are both crucial for methylation of euchromatin at H3-K9. *Genes Dev.*, 19, 815-26. ↗

Peters, G., Yoshimoto, S., Shinkai, Y., Imai, Y., Tachibana, M., Takahashi, A. et al. (2012). DNA damage signaling triggers degradation of histone methyltransferases through APC/C(Cdh1) in senescent cells. *Mol. Cell*, 45, 123-31. ↗

### Editions

2013-07-15	Edited	D'Eustachio, P., Matthews, L.
2013-07-15	Authored	Orlic-Milacic, M.
2013-09-03	Reviewed	Samarajiwa, S.

## Cdh1:APC/C ubiquitinates EHMT1 and EHMT2 ↗

**Location:** [Senescence-Associated Secretory Phenotype \(SASP\)](#)

**Stable identifier:** R-HSA-3788724

**Type:** transition

**Compartments:** nucleoplasm

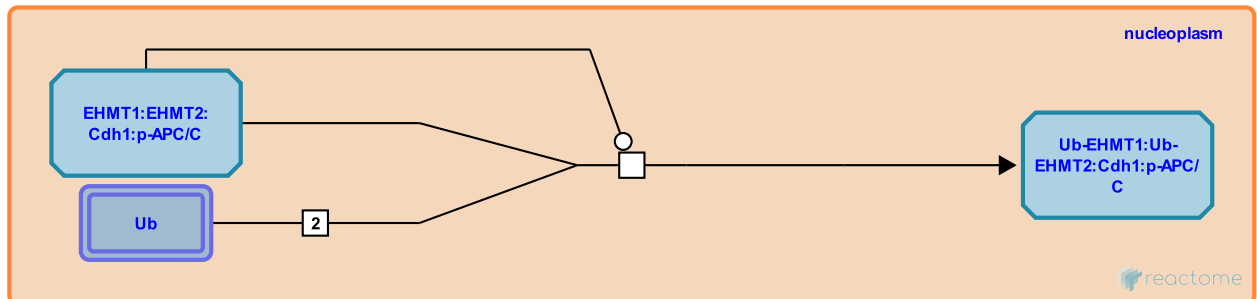

Cdh1:APC/C complex, stabilized by the DNA damage-induced ATM-TP53-CDKN1A axis, ubiquitinates EHMT1 (GLP) and EHMT2 (G9a) histone methyltransferases, targeting them for degradation (Takahashi et al. 2012).

**Preceded by:** [Cdh1:APC/C complex binds EHMT1:EHMT2](#)

### Literature references

Peters, G., Yoshimoto, S., Shinkai, Y., Imai, Y., Tachibana, M., Takahashi, A. et al. (2012). DNA damage signaling triggers degradation of histone methyltransferases through APC/C(Cdh1) in senescent cells. *Mol. Cell*, 45, 123-31. ↗

### Editions

2013-07-15	Edited	D'Eustachio, P., Matthews, L.
2013-07-15	Authored	Orlic-Milacic, M.
2013-09-03	Reviewed	Samarajiwa, S.



## EHMT1:EHMT2 methylates IL6 promoter [↗](#)

**Location:** [Senescence-Associated Secretory Phenotype \(SASP\)](#)

**Stable identifier:** R-HSA-3788748

**Type:** transition

**Compartments:** nucleoplasm

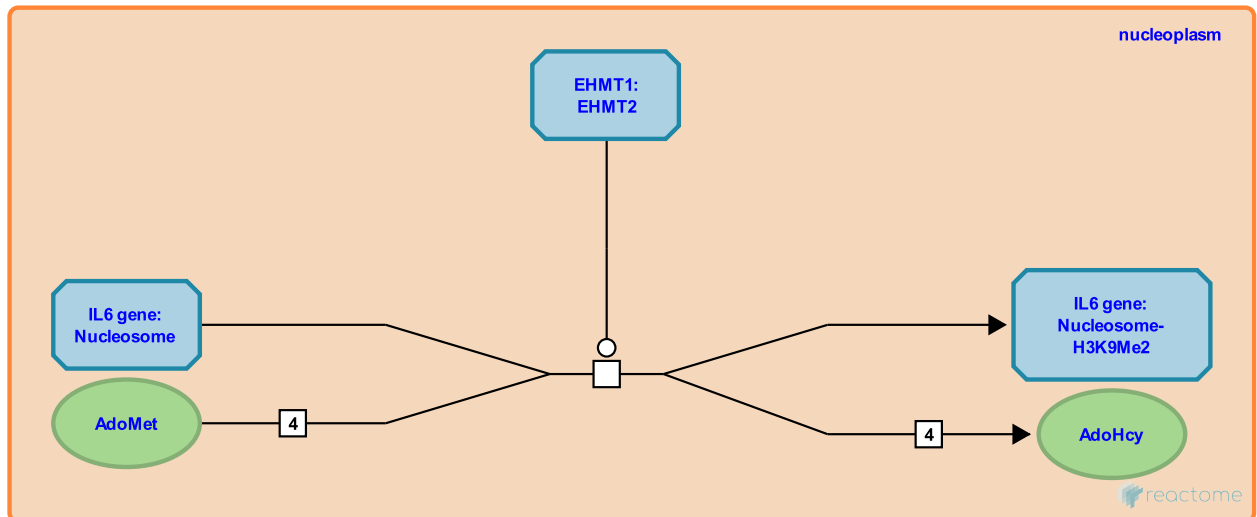

EHMT1 (GLP) and EHMT2 (G9a) histone methyltransferases dimethylate histone H3 (HIST1H3A) on lysine residue 10, creating an H3K9Me2 mark on nucleosomes associated with the IL6 promoter (Takahashi et al. 2012).

### Literature references

Peters, G., Yoshimoto, S., Shinkai, Y., Imai, Y., Tachibana, M., Takahashi, A. et al. (2012). DNA damage signaling triggers degradation of histone methyltransferases through APC/C(Cdh1) in senescent cells. *Mol. Cell*, 45, 123-31. [↗](#)

### Editions

2013-07-15	Edited	D'Eustachio, P., Matthews, L.
2013-07-15	Authored	Orlic-Milacic, M.
2013-09-03	Reviewed	Samarajiwa, S.

## EHMT1:EHMT2 methylates IL8 promoter [↗](#)

**Location:** [Senescence-Associated Secretory Phenotype \(SASP\)](#)

**Stable identifier:** R-HSA-3788745

**Type:** transition

**Compartments:** nucleoplasm

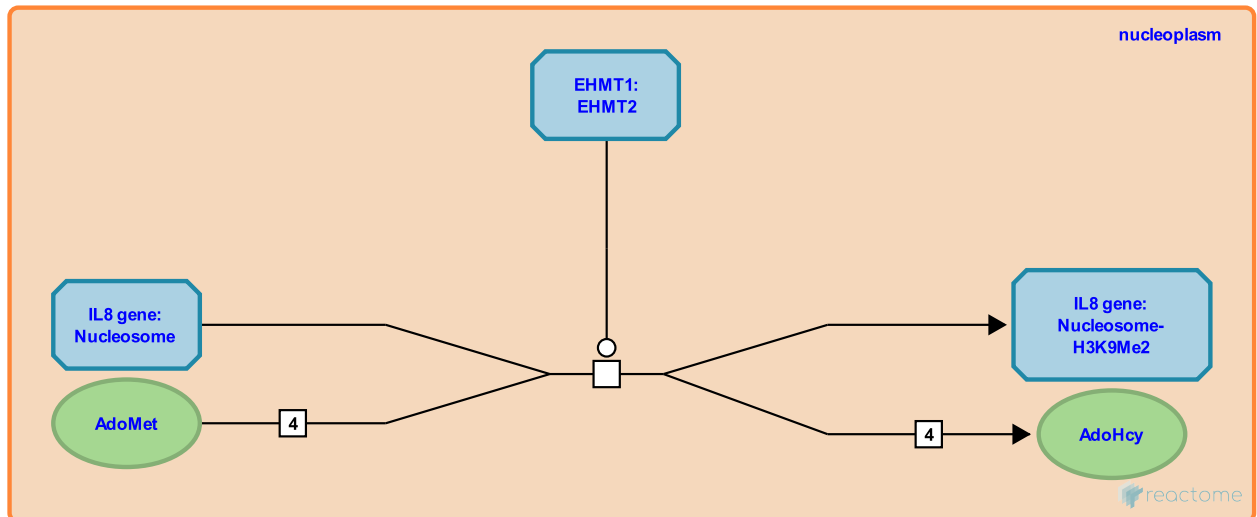

EHMT1 (GLP) and EHMT2 (G9a) histone methyltransferases dimethylate histone H3 (HIST1H3A) on lysine residue 10, creating an H3K9Me2 mark on nucleosomes associated with the IL8 promoter (Takahashi et al. 2012).

### Literature references

Peters, G., Yoshimoto, S., Shinkai, Y., Imai, Y., Tachibana, M., Takahashi, A. et al. (2012). DNA damage signaling triggers degradation of histone methyltransferases through APC/C(Cdh1) in senescent cells. *Mol. Cell*, 45, 123-31. [↗](#)

### Editions

2013-07-15	Edited	D'Eustachio, P., Matthews, L.
2013-07-15	Authored	Orlic-Milacic, M.
2013-09-03	Reviewed	Samarajiwa, S.

## ERK1/2/5 activate RSK1/2/3 ↗

**Location:** Senescence-Associated Secretory Phenotype (SASP)

**Stable identifier:** R-HSA-198746

**Type:** transition

**Compartments:** nucleoplasm

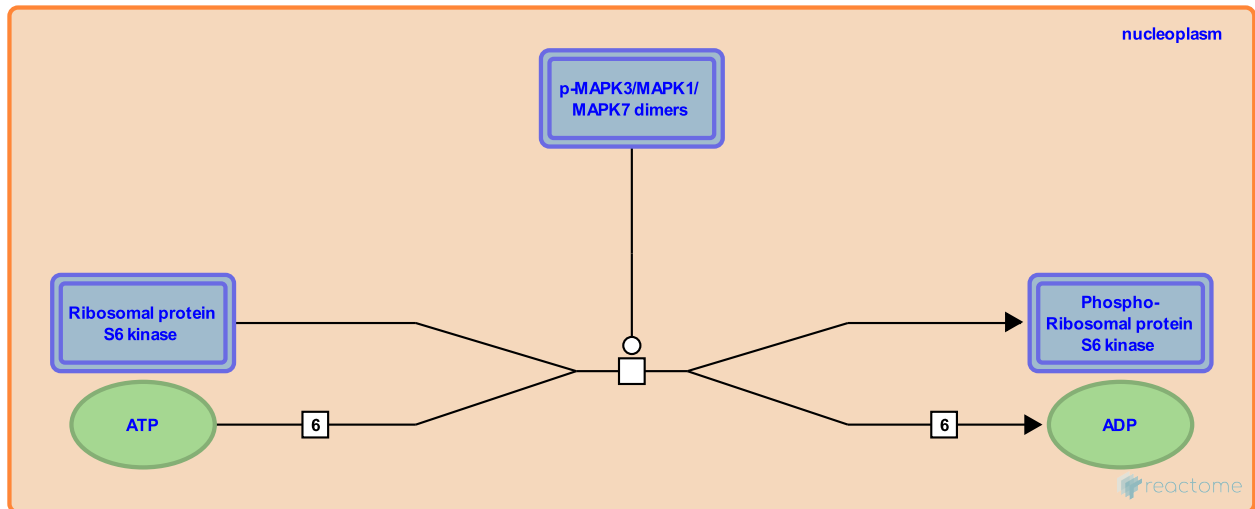

The p90 ribosomal S6 kinases (RSK1-4) comprise a family of serine/threonine kinases that lie at the terminus of the ERK pathway. RSK family members are unusual among serine/threonine kinases in that they contain two distinct kinase domains, both of which are catalytically functional. The C-terminal kinase domain is believed to be involved in autophosphorylation, a critical step in RSK activation, whereas the N-terminal kinase domain, which is homologous to members of the AGC superfamily of kinases, is responsible for the phosphorylation of all known exogenous substrates of RSK.

RSKs can be activated by the ERKs (ERK1, 2, 5) in the cytoplasm as well as in the nucleus, they both have cytoplasmic and nuclear substrates, and they are able to move from nucleus to cytoplasm. Efficient RSK activation by ERKs requires its interaction through a docking site located near the RSK C terminus. The mechanism of RSK activation has been studied mainly with regard to ERK1 and ERK2. RSK activation leads to the phosphorylation of four essential residues Ser239, Ser381, Ser398, and Thr590, and two additional sites, Thr377 and Ser749 (the amino acid numbering refers to RSK1). ERK is thought to play at least two roles in RSK1 activation. First, activated ERK phosphorylates RSK1 on Thr590, and possibly on Thr377 and Ser381, and second, ERK brings RSK1 into close proximity to membrane-associated kinases that may phosphorylate RSK1 on Ser381 and Ser398.

Moreover, RSKs and ERK1/2 form a complex that transiently dissociates upon growth factor signalling. Complex dissociation requires phosphorylation of RSK1 serine 749, a growth factor regulated phosphorylation site located near the ERK docking site. Serine 749 is phosphorylated by the N-terminal kinase domain of RSK1 itself. ERK1/2 docking to RSK2 and RSK3 is also regulated in a similar way. The length of RSK activation following growth factor stimulation depends on the duration of the RSK/ERK complex, which, in turn, differs among the different RSK isoforms. RSK1 and RSK2 readily dissociate from ERK1/2 following growth factor stimulation, but RSK3 remains associated with active ERK1/2 longer, and also remains active longer than RSK1 and RSK2.

**Followed by:** RPS6KA1/2/3 phosphorylates CEBPB on S321

## Literature references

Blenis, J., Richards, SA., Roux, PP. (2003). Phosphorylation of p90 ribosomal S6 kinase (RSK) regulates extracellular signal-regulated kinase docking and RSK activity. *Mol Cell Biol*, 23, 4796-804. ↗

Ranganathan, A., Cobb, MH., Sturgill, TW., Pearson, GW., Chrestensen, CA. (2006). The MAP kinase ERK5 binds to and phosphorylates p90 RSK. *Arch Biochem Biophys*, 449, 8-16. ↗

## Editions

2006-10-10	Authored	Annibali, D., Nasi, S.
2007-11-08	Reviewed	Greene, LA.
2013-07-15	Edited	D'Eustachio, P., Matthews, L.

## MAPK3 (ERK1) and MAPK1 (ERK2) phosphorylate CEBPB ↗

**Location:** [Senescence-Associated Secretory Phenotype \(SASP\)](#)

**Stable identifier:** R-HSA-3857329

**Type:** transition

**Compartments:** nucleoplasm

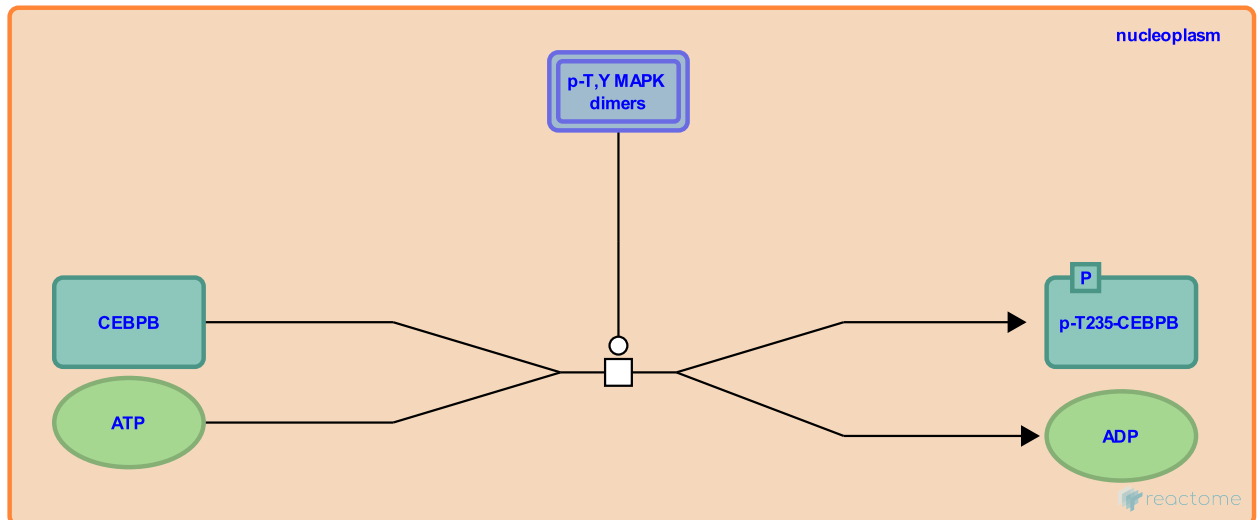

Phosphorylation of CEBPB (C/EBP-beta) transcription factor on threonine residue T235 happens downstream of activated RAS, is mediated by MAPKs - likely MAPK3 (ERK1) and MAPK1 (ERK2), and positively affects CEBPB-mediated transcription of IL6 (Nakajima et al. 1993).

**Preceded by:** [Activated STAT3 positively regulates CEBPB transcription](#)

**Followed by:** [RPS6KA1/2/3 phosphorylates CEBPB on S321](#)

### Literature references

Kinoshita, S., Kishimoto, T., Nakajima, T., Akira, S., Naruto, M., Sasaki, K. et al. (1993). Phosphorylation at threonine-235 by a ras-dependent mitogen-activated protein kinase cascade is essential for transcription factor NF-IL6. *Proc. Natl. Acad. Sci. U.S.A.*, 90, 2207-11. ↗

### Editions

2013-07-15	Edited	D'Eustachio, P., Matthews, L.
2013-07-15	Authored	Orlic-Milacic, M.
2013-09-03	Reviewed	Samarajiwa, S.

## RPS6KA1/2/3 phosphorylates CEBPB on S321 [↗](#)

**Location:** [Senescence-Associated Secretory Phenotype \(SASP\)](#)

**Stable identifier:** R-HSA-3857328

**Type:** transition

**Compartments:** nucleoplasm

**Inferred from:** [RPS6KA1/2/3 phosphorylates Cebpb on S273 \(Homo sapiens\)](#)

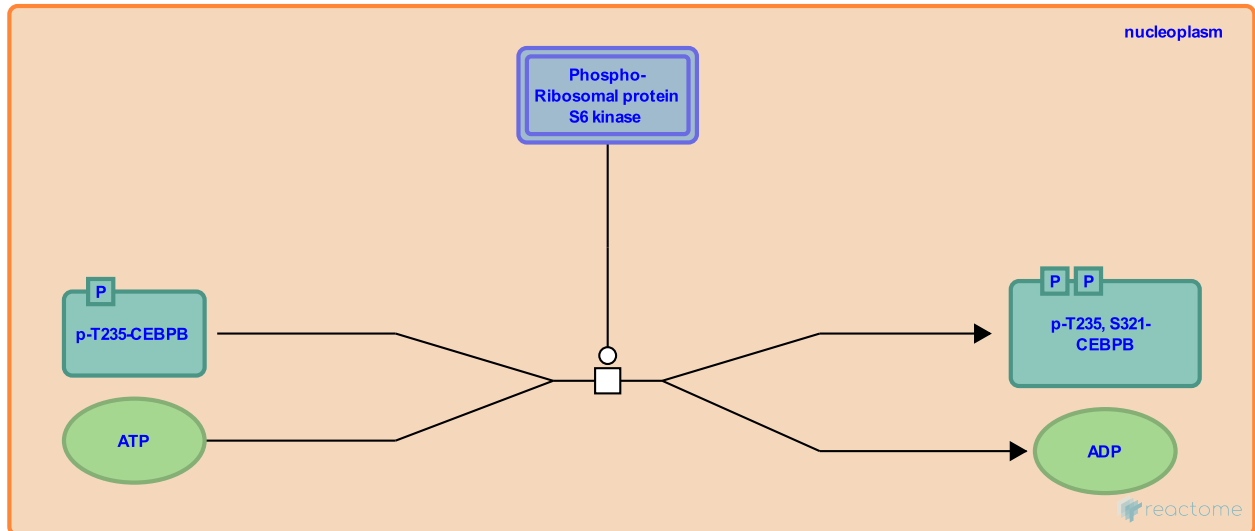

Phosphorylation of CEBPB (C/EBP-beta) serine residue S321 by ERK1/2-activated RSK1, RSK2 or RSK3, downstream of activated RAS, is necessary for the relief of CEBPB autoinhibition (Lee et al. 2010). Phosphorylation on other sites may also be involved in CEBPB activation.

**Preceded by:** [MAPK3 \(ERK1\) and MAPK1 \(ERK2\) phosphorylate CEBPB](#), [ERK1/2/5 activate RSK1/2/3](#)

**Followed by:** [CEBPB homodimerization](#)

### Literature references

Shuman, JD., Cohen, MS., Sakchaisri, K., Taunton, J., Lee, S., Sebastian, T. et al. (2010). RSK-mediated phosphorylation in the C/EBP{beta} leucine zipper regulates DNA binding, dimerization, and growth arrest activity. *Mol. Cell Biol.*, 30, 2621-35. [↗](#)

### Editions

2013-07-15	Edited	D'Eustachio, P., Matthews, L.
2013-07-15	Authored	Orlic-Milacic, M.
2013-09-03	Reviewed	Samarajiwa, S.

## CEBPB homodimerization ↗

**Location:** [Senescence-Associated Secretory Phenotype \(SASP\)](#)

**Stable identifier:** R-HSA-3857336

**Type:** binding

**Compartments:** nucleoplasm

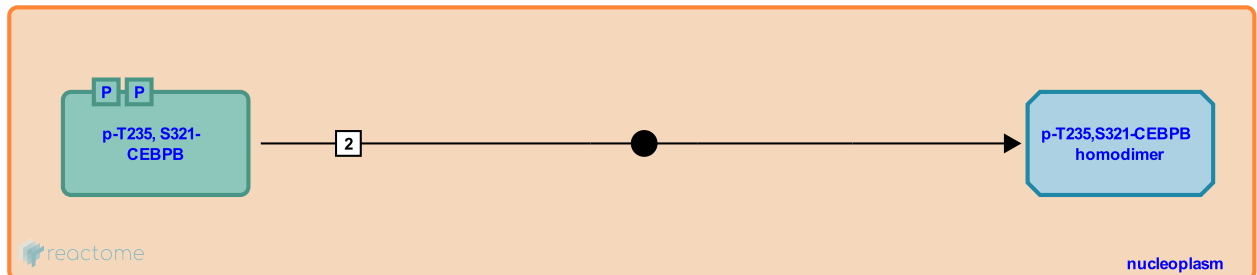

RSK1/2/3-mediated phosphorylation of CEBPB promotes the formation of CEBPB homodimers which are active as transcription factors (Lee, Miller et al. 2010; Lee, Shuman et al. 2010).

**Preceded by:** [RPS6KA1/2/3 phosphorylates CEBPB on S321](#)

**Followed by:** [Activated CEBPB and NFKB complex bind IL6 promoter](#), [Activated CEBPB and NFKB complex bind IL8 promoter](#), [Activated CEBPB binds CDKN2B promoter](#)

### Literature references

Shuman, JD., Cohen, MS., Sakchaisri, K., Taunton, J., Lee, S., Sebastian, T. et al. (2010). RSK-mediated phosphorylation in the C/EBP{beta} leucine zipper regulates DNA binding, dimerization, and growth arrest activity. *Mol. Cell. Biol.*, 30, 2621-35. ↗

Shuman, JD., Miller, M., Johnson, PF., Lee, S. (2010). CCAAT/Enhancer-binding protein beta DNA binding is auto-inhibited by multiple elements that also mediate association with p300/CREB-binding protein (CBP). *J. Biol. Chem.*, 285, 21399-410. ↗

### Editions

2013-07-15	Edited	D'Eustachio, P., Matthews, L.
2013-07-15	Authored	Orlic-Milacic, M.
2013-09-03	Reviewed	Samarajiwa, S.

## Activated CEBPB and NFKB complex bind IL6 promoter ↗

**Location:** [Senescence-Associated Secretory Phenotype \(SASP\)](#)

**Stable identifier:** R-HSA-3857305

**Type:** binding

**Compartments:** nucleoplasm

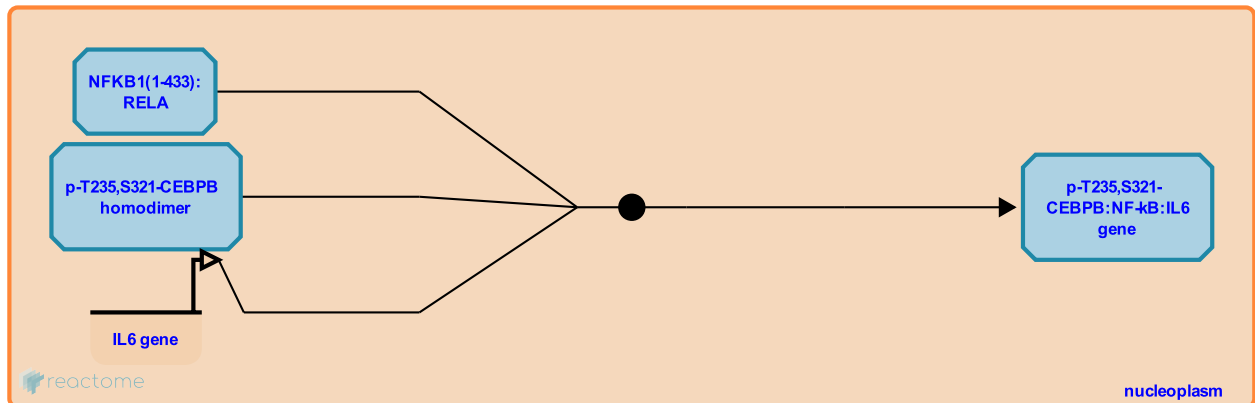

RSK6A1/2/3-mediated phosphorylation of CEBPB downstream of activated RAS stimulates CEBPB homodimerization and DNA binding (Lee, Shuman et al. 2010) and, specifically, RAS-induced CEBPB activation stimulates CEBPB binding to the IL6 promoter (Kuilman et al. 2008; Lee, Shuman et al. 2010). RAS-activated CEBPB is able to recruit additional transcription activators, such as EP300, to the IL6 promoter (Lee, Miller et al. 2010). NFKB transcription complex, activated by interleukin-1-alpha (IL1A) signaling (Jimi et al. 1996, Hartupée et al. 2008, Orjalo et al. 2009), also binds the promoter of the IL6 gene (Shimizu et al. 1990, Libermann and Baltimore 1990) and cooperates with CEBPB in the activation of IL6 transcription (Matsusaka et al. 1993).

**Preceded by:** [CEBPB homodimerization](#)

**Followed by:** [Regulation of IL6 transcription](#)

### Literature references

- Shuman, JD., Cohen, MS., Sakchaisri, K., Taunton, J., Lee, S., Sebastian, T. et al. (2010). RSK-mediated phosphorylation in the C/EBP{beta} leucine zipper regulates DNA binding, dimerization, and growth arrest activity. *Mol. Cell Biol.*, 30, 2621-35. ↗
- Koga, T., Suda, T., Hirata, M., Takahashi, N., Jimi, E., Ikebe, T. (1996). Interleukin-1 alpha activates an NF-kappaB-like factor in osteoclast-like cells. *J. Biol. Chem.*, 271, 4605-8. ↗
- Li, X., Hartupée, J., Hamilton, T. (2008). Interleukin 1alpha-induced NFkappaB activation and chemokine mRNA stabilization diverge at IRAK1. *J. Biol. Chem.*, 283, 15689-93. ↗
- Shimizu, H., Okamoto, S., Mitomo, K., Watanabe, T., Yamamoto, K. (1990). Involvement of a NF-kappa B-like transcription factor in the activation of the interleukin-6 gene by inflammatory lymphokines. *Mol. Cell Biol.*, 10, 561-8. ↗
- Orjalo, AV., Scott, GK., Campisi, J., Bhaumik, D., Gengler, BK. (2009). Cell surface-bound IL-1alpha is an upstream regulator of the senescence-associated IL-6/IL-8 cytokine network. *Proc. Natl. Acad. Sci. U.S.A.*, 106, 17031-6. ↗

### Editions

2013-07-15	Edited	D'Eustachio, P., Matthews, L.
2013-07-15	Authored	Orlic-Milacic, M.
2013-09-03	Reviewed	Samarajiwa, S.
2013-09-30	Revised	Orlic-Milacic, M.
2019-10-18	Reviewed	Vegi, NM.
2019-11-01	Edited	Orlic-Milacic, M.

## Regulation of IL6 transcription ↗

**Location:** Senescence-Associated Secretory Phenotype (SASP)

**Stable identifier:** R-HSA-3790130

**Type:** omitted

**Compartments:** nucleoplasm, extracellular region

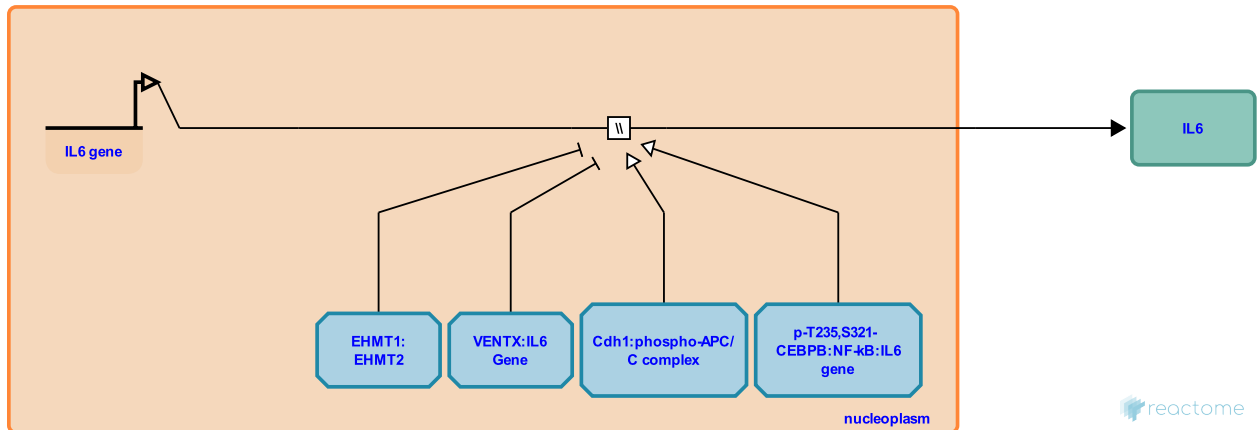

Methylation of the IL6 promoter by EHMT1:EHMT2 (GLP:G9a) histone methyltransferases inhibits IL6 transcription, while Cdh1:APC/C-mediated degradation of EHTM1:EHTM2 downstream of the ATM-TP53-CDKN1A axis stimulates IL6 transcription (Takahashi et al. 2012). Oncogenic RAS signaling stimulates activation of the CEBPB transcription factor (C/EBP-beta) which binds IL6 promoter and stimulates IL6 transcription (Kuilman et al. 2008, Lee et al. 2010). NF kappa B transcription factor is also activated in senescent cells (Chien et al. 2011) through interleukin-1-alpha (IL1A) signaling (Jimi et al. 1996, Hartupee et al. 2008, Orjalo et al. 2009), and it cooperates with CEBPB in the activation of IL6 transcription (Shimizu et al. 1990, Libermann and Baltimore 1990, Matsusaka et al. 1993, Acosta et al. 2008). Autocrine IL6 signaling stimulates CEBPB expression (Kuilman et al. 2008), creating a positive feedback loop. STAT3, activated by IL6 signaling cascade is necessary for CEBPB transcription, but the direct binding of STAT3 to the CEBPB promoter has not been demonstrated (Niehof et al. 2001).

VENTX inhibits transcription of the Interleukin-6 (IL6) gene, thus promoting differentiation of primary monocytes into dendritic cells (Wu et al. 2014). The NFKB complex which competes with VENTX for binding to the IL6 gene promoter (Wu et al. 2014). It is not known whether histone H3K9 dimethylation at the VENTX promoter (Takahashi et al. 2012) is involved in VENTX-mediated transcriptional repression of IL6.

**Preceded by:** Activated CEBPB and NFKB complex bind IL6 promoter

### Literature references

- Shuman, JD., Cohen, MS., Sakchaisri, K., Taunton, J., Lee, S., Sebastian, T. et al. (2010). RSK-mediated phosphorylation in the C/EBP{beta} leucine zipper regulates DNA binding, dimerization, and growth arrest activity. *Mol. Cell Biol.*, 30, 2621-35. ↗
- Koga, T., Suda, T., Hirata, M., Takahashi, N., Jimi, E., Ikebe, T. (1996). Interleukin-1 alpha activates an NF-kappaB-like factor in osteoclast-like cells. *J. Biol. Chem.*, 271, 4605-8. ↗
- Raguz, S., Bernard, D., Gil, J., Da Costa, M., Fumagalli, M., O'Loughlen, A. et al. (2008). Chemokine signaling via the CXCR2 receptor reinforces senescence. *Cell*, 133, 1006-18. ↗
- Baltimore, D., Libermann, TA. (1990). Activation of interleukin-6 gene expression through the NF-kappa B transcription factor. *Mol. Cell Biol.*, 10, 2327-34. ↗
- Peters, G., Yoshimoto, S., Shinkai, Y., Imai, Y., Tachibana, M., Takahashi, A. et al. (2012). DNA damage signaling triggers degradation of histone methyltransferases through APC/C(Cdh1) in senescent cells. *Mol. Cell*, 45, 123-31. ↗



## Editions

2013-07-15	Edited	D'Eustachio, P., Matthews, L.
2013-07-15	Authored	Orlic-Milacic, M.
2013-09-03	Reviewed	Samarajiwa, S.
2013-09-30	Revised	Orlic-Milacic, M.
2019-06-28	Revised	Orlic-Milacic, M.
2019-10-18	Reviewed	Vegi, NM.
2019-11-01	Edited	Orlic-Milacic, M.

## Activated STAT3 positively regulates CEBPB transcription ↗

**Location:** [Senescence-Associated Secretory Phenotype \(SASP\)](#)

**Stable identifier:** R-HSA-3858387

**Type:** omitted

**Compartments:** nucleoplasm

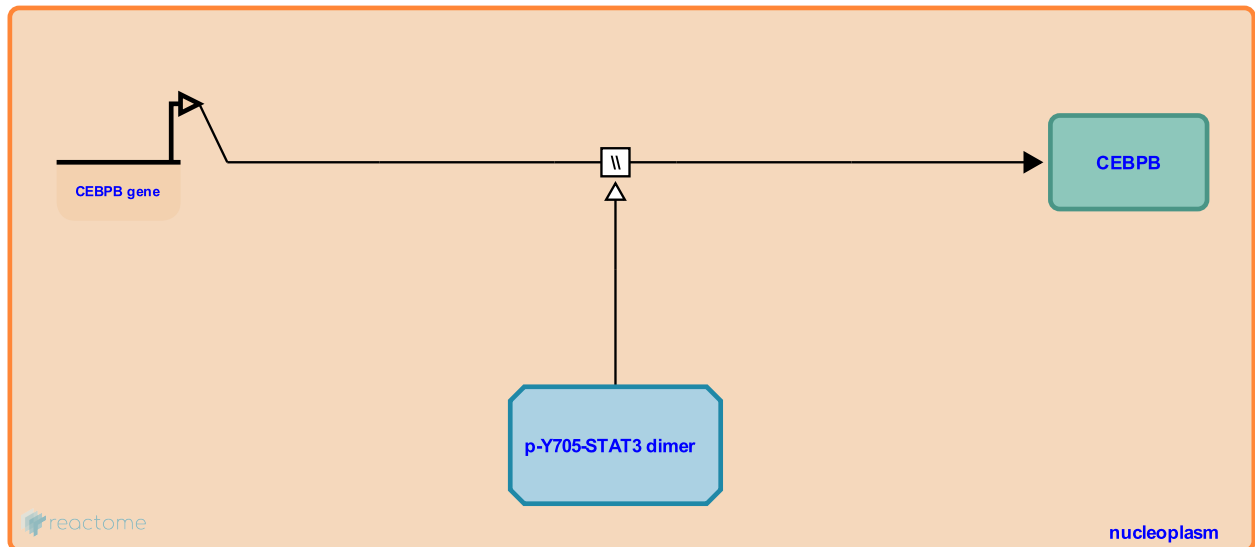

STAT3, activated by IL6 signaling cascade, is necessary for CEBPB transcription, but direct binding of STAT3 to the CEBPB promoter has not been demonstrated (Niehof et al. 2001). As CEBPB activates IL6 transcription in response to oncogenic RAS signaling, and IL6 activates CEBPB transcription (Niehof et al. 2001, Kuilman et al. 2008, Lee et al. 2010), a positive feedback loop exists between CEBPB and IL6.

**Followed by:** [MAPK3 \(ERK1\) and MAPK1 \(ERK2\) phosphorylate CEBPB](#)

### Literature references

- Shuman, JD., Cohen, MS., Sakchaisri, K., Taunton, J., Lee, S., Sebastian, T. et al. (2010). RSK-mediated phosphorylation in the C/EBPβ leucine zipper regulates DNA binding, dimerization, and growth arrest activity. *Mol. Cell Biol.*, 30, 2621-35. ↗
- Kuilman, T., Mooi, WJ., Douma, S., Aarden, LA., van Doorn, R., Michaloglou, C. et al. (2008). Oncogene-induced senescence relayed by an interleukin-dependent inflammatory network. *Cell*, 133, 1019-31. ↗
- Bischoff, SC., Streetz, K., Horn, F., Rakemann, T., Manns, MP., Trautwein, C. et al. (2001). Interleukin-6-induced tethering of STAT3 to the LAP/C/EBPβ promoter suggests a new mechanism of transcriptional regulation by STAT3. *J. Biol. Chem.*, 276, 9016-27. ↗

### Editions

2013-07-15	Edited	D'Eustachio, P., Matthews, L.
2013-07-15	Authored	Orlic-Milacic, M.
2013-09-03	Reviewed	Samarajiwa, S.

## Activated CEBPB and NFKB complex bind IL8 promoter ↗

**Location:** [Senescence-Associated Secretory Phenotype \(SASP\)](#)

**Stable identifier:** R-HSA-3857308

**Type:** binding

**Compartments:** nucleoplasm

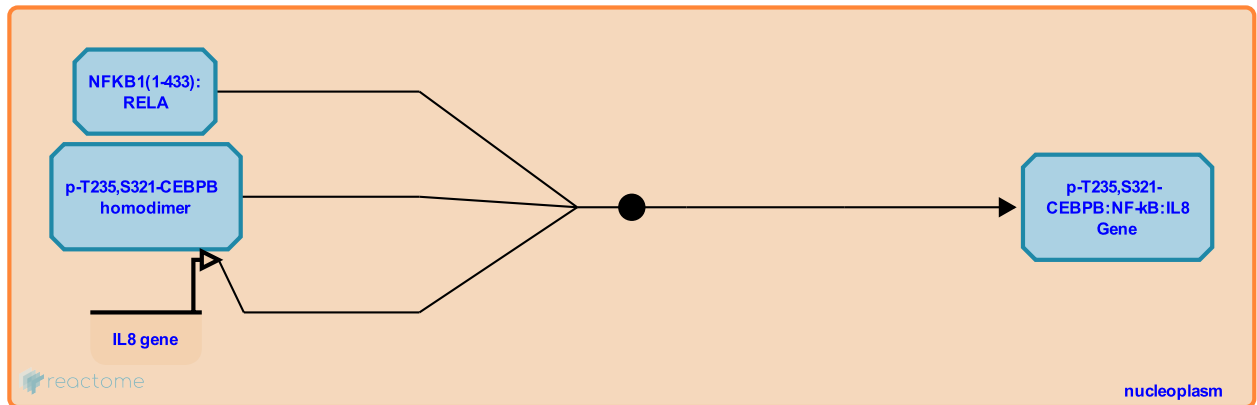

RAS-mediated activation of CEBPB (C/EBP-beta) stimulates CEBPB binding to the IL8 promoter (Kuilman et al. 2008). NFKB transcription complex, activated by interleukin-1-alpha (IL1A) signaling (Jimi et al. 1996, Hartupée et al. 2008, Orjalo et al. 2009), also binds the promoter of the IL8 gene (Kunsch and Rosen 1993) and cooperates with CEBPB in the activation of IL8 transcription (Matsusaka et al. 1993, Stein and Baldwin 1993).

**Preceded by:** [CEBPB homodimerization](#)

**Followed by:** [Stimulation of IL8 transcription in senescent cells](#)

### Literature references

- Koga, T., Suda, T., Hirata, M., Takahashi, N., Jimi, E., Ikebe, T. (1996). Interleukin-1 alpha activates an NF-kappaB-like factor in osteoclast-like cells. *J. Biol. Chem.*, 271, 4605-8. ↗
- Stein, B., Baldwin, AS. (1993). Distinct mechanisms for regulation of the interleukin-8 gene involve synergism and cooperativity between C/EBP and NF-kappa B. *Mol. Cell. Biol.*, 13, 7191-8. ↗
- Li, X., Hartupée, J., Hamilton, T. (2008). Interleukin 1alpha-induced NFkappaB activation and chemokine mRNA stabilization diverge at IRAK1. *J. Biol. Chem.*, 283, 15689-93. ↗
- Orjalo, AV., Scott, GK., Campisi, J., Bhaumik, D., Gengler, BK. (2009). Cell surface-bound IL-1alpha is an upstream regulator of the senescence-associated IL-6/IL-8 cytokine network. *Proc. Natl. Acad. Sci. U.S.A.*, 106, 17031-6. ↗
- Matsushima, K., Matsusaka, T., Kishimoto, T., Fujikawa, K., Mukaida, N., Nishio, Y. et al. (1993). Transcription factors NF-IL6 and NF-kappa B synergistically activate transcription of the inflammatory cytokines, interleukin 6 and interleukin 8. *Proc. Natl. Acad. Sci. U.S.A.*, 90, 10193-7. ↗

### Editions

2013-07-15	Edited	D'Eustachio, P., Matthews, L.
2013-07-15	Authored	Orlic-Milacic, M.
2013-09-03	Reviewed	Samarajiwa, S.
2013-09-30	Revised	Orlic-Milacic, M.

## Stimulation of IL8 transcription in senescent cells ↗

**Location:** Senescence-Associated Secretory Phenotype (SASP)

**Stable identifier:** R-HSA-3790137

**Type:** omitted

**Compartments:** nucleoplasm, extracellular region

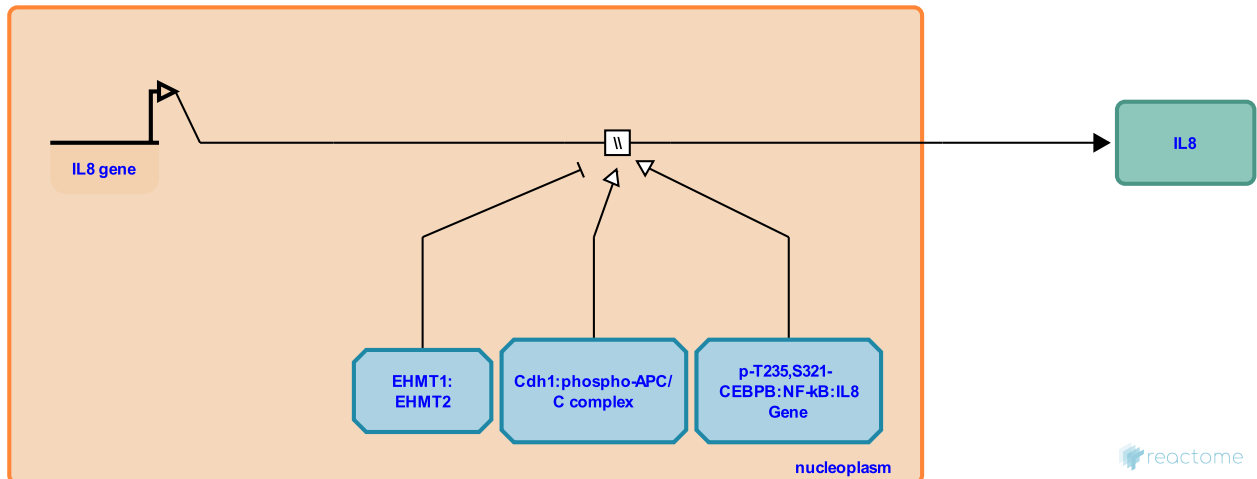

Methylation of the IL8 promoter by EHMT1:EHMT2 (GLP:G9a) histone methyltransferases inhibits IL8 transcription, while Cdh1:APC/C-mediated degradation of EHTM1:EHTM2 downstream of the ATM-TP53-CDKN1A axis stimulates IL8 transcription (Takahashi et al. 2012). CEBPB transcription factor, activated by oncogenic RAS signaling, binds IL8 promoter and stimulates IL8 transcription (Kuilman et al. 2008). The NF-kappa-B transcription factor is also activated in senescent cells (Chien et al. 2011) through interleukin-1-alpha (IL1A) signaling (Jimi et al. 1996, Hartupée et al. 2008, Orjalo et al. 2009), and it cooperates with CEBPB in the activation of IL8 transcription (Kunsch and Rosen 1993, Stein and Baldwin 1993, Matsusaka et al. 1993, Acosta et al. 2008).

**Preceded by:** Activated CEBPB and NFKB complex bind IL8 promoter

### Literature references

- Koga, T., Suda, T., Hirata, M., Takahashi, N., Jimi, E., Ikebe, T. (1996). Interleukin-1 alpha activates an NF-kappaB-like factor in osteoclast-like cells. *J. Biol. Chem.*, 271, 4605-8. ↗
- Stein, B., Baldwin, AS. (1993). Distinct mechanisms for regulation of the interleukin-8 gene involve synergism and cooperativity between C/EBP and NF-kappa B. *Mol. Cell. Biol.*, 13, 7191-8. ↗
- Li, X., Hartupée, J., Hamilton, T. (2008). Interleukin 1alpha-induced NFkappaB activation and chemokine mRNA stabilization diverge at IRAK1. *J. Biol. Chem.*, 283, 15689-93. ↗
- Orjalo, AV., Scott, GK., Campisi, J., Bhaumik, D., Gengler, BK. (2009). Cell surface-bound IL-1alpha is an upstream regulator of the senescence-associated IL-6/IL-8 cytokine network. *Proc. Natl. Acad. Sci. U.S.A.*, 106, 17031-6. ↗
- Matsushima, K., Matsusaka, T., Kishimoto, T., Fujikawa, K., Mukaida, N., Nishio, Y. et al. (1993). Transcription factors NF-IL6 and NF-kappa B synergistically activate transcription of the inflammatory cytokines, interleukin 6 and interleukin 8. *Proc. Natl. Acad. Sci. U.S.A.*, 90, 10193-7. ↗

### Editions

2013-07-15	Edited	D'Eustachio, P., Matthews, L.
2013-07-15	Authored	Orlic-Milacic, M.
2013-09-03	Reviewed	Samarajiwa, S.
2013-09-30	Revised	Orlic-Milacic, M.

## Activated CEBPB binds CDKN2B promoter ↗

**Location:** Senescence-Associated Secretory Phenotype (SASP)

**Stable identifier:** R-HSA-3857345

**Type:** binding

**Compartments:** nucleoplasm

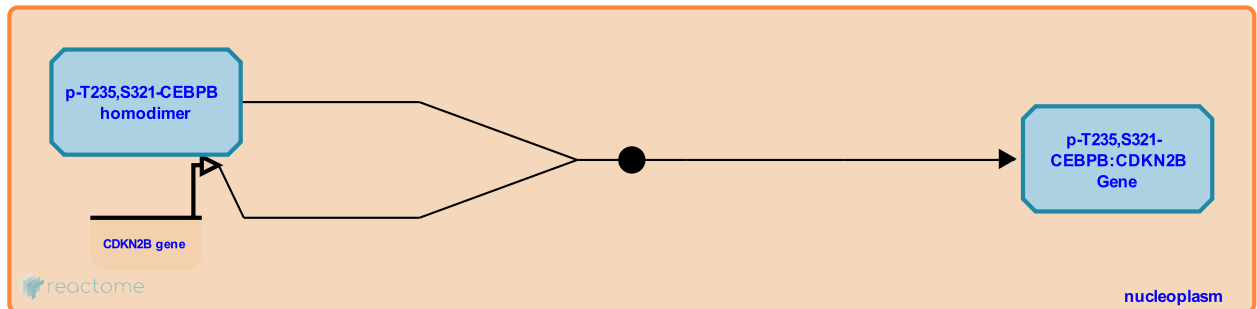

The CEBPB transcription factor, activated by oncogenic RAS signaling, binds the CDKN2B promoter (Kuilman et al. 2008).

**Preceded by:** CEBPB homodimerization

**Followed by:** Activated CEBPB stimulates transcription of CDKN2B

### Literature references

Kuilman, T., Mooi, WJ., Douma, S., Aarden, LA., van Doorn, R., Michaloglou, C. et al. (2008). Oncogene-induced senescence relayed by an interleukin-dependent inflammatory network. *Cell*, 133, 1019-31. ↗

### Editions

2013-07-15	Edited	D'Eustachio, P., Matthews, L.
2013-07-15	Authored	Orlic-Milacic, M.
2013-09-03	Reviewed	Samarajiwa, S.

## Activated CEBPB stimulates transcription of CDKN2B ↗

**Location:** Senescence-Associated Secretory Phenotype (SASP)

**Stable identifier:** R-HSA-3857348

**Type:** omitted

**Compartments:** nucleoplasm

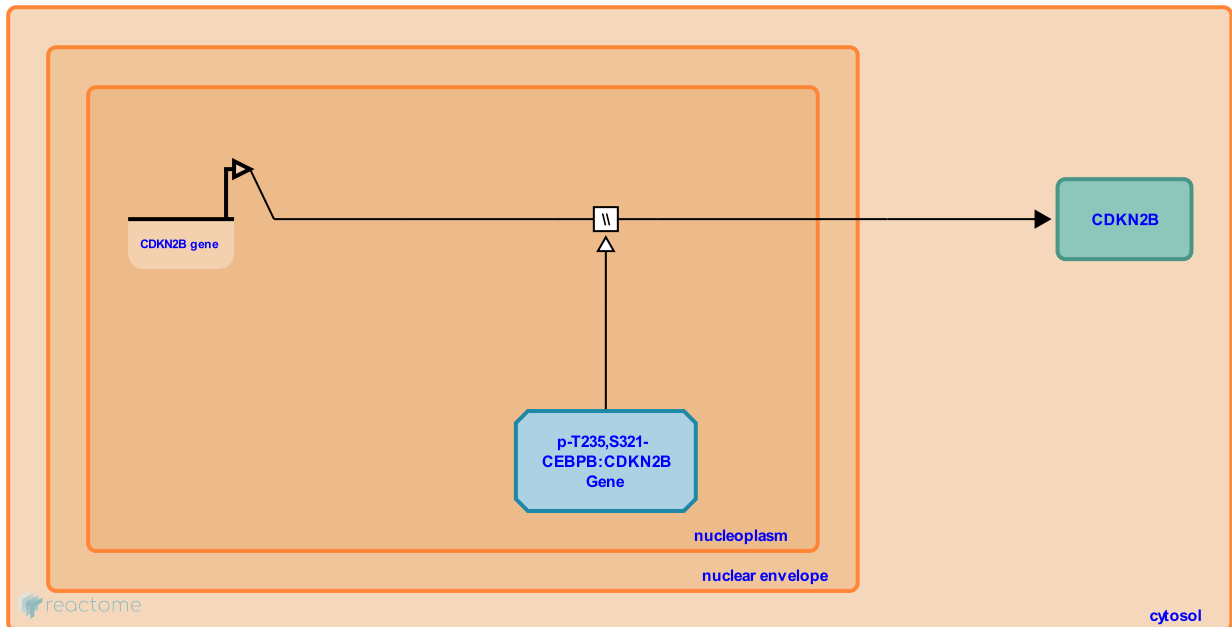

Once bound to the CDKN2B promoter, CEBPB stimulates CDKN2B transcription, contributing to cell cycle arrest in oncogene induced senescence (Kuilman et al. 2008). In addition, since CEBPB expression is stimulated by IL6 signaling, with IL6 itself being a transcriptional target of CEBPB (Neihof et al. 2001, Kuilman et al. 2008, Lee et al. 2010), IL6-CEBPB-CDKN2B axis provides an autocrine SASP-mediated growth arrest mechanism.

**Preceded by:** Activated CEBPB binds CDKN2B promoter

**Followed by:** Association of INK4 family proteins with CDK4/6

### Literature references

Kuilman, T., Mooi, WJ., Douma, S., Aarden, LA., van Doorn, R., Michaloglou, C. et al. (2008). Oncogene-induced senescence relayed by an interleukin-dependent inflammatory network. *Cell*, 133, 1019-31. ↗

### Editions

2013-07-15	Edited	D'Eustachio, P., Matthews, L.
2013-07-15	Authored	Orlic-Milacic, M.
2013-09-03	Reviewed	Samarajiwa, S.

## Association of INK4 family proteins with CDK4/6 [↗](#)

**Location:** [Senescence-Associated Secretory Phenotype \(SASP\)](#)

**Stable identifier:** R-HSA-182594

**Type:** binding

**Compartments:** cytosol

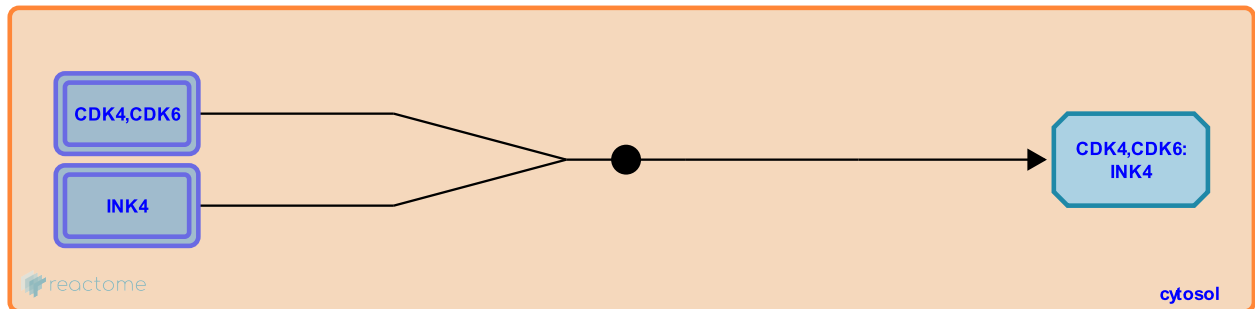

Prior to mitogen activation, the inhibitory proteins of the INK4 family (p15, p16, p18, and p19) associate with the catalytic domains of free CDK4 and CDK6, preventing their association with D type cyclins (CCND1, CCND2 and CCND3), and thus their activation and their inhibitory phosphorylation of the RB family (Serrano et al. 1993, Hannon and Beach 1994, Guan et al. 1994, Guan et al. 1996, Parry et al. 1995). Inactivation and defects of RB1 strongly upregulate p16INK4A (Parry et al. 1995).

**Preceded by:** [Activated CEBPB stimulates transcription of CDKN2B](#)

### Literature references

- Hannon, GJ., Serrano, M., Beach, D. (1993). A new regulatory motif in cell-cycle control causing specific inhibition of cyclin D/CDK4. *Nature*, 366, 704-7. [↗](#)
- Matera, AG., Xiong, Y., Guan, KL., Zariwala, M., Li, Y., O'Keefe, CL. et al. (1996). Isolation and characterization of p19INK4d, a p16-related inhibitor specific to CDK6 and CDK4. *Mol Biol Cell*, 7, 57-70. [↗](#)
- Peters, G., Bates, S., Mann, DJ., Parry, D. (1995). Lack of cyclin D-Cdk complexes in Rb-negative cells correlates with high levels of p16INK4/MTS1 tumour suppressor gene product. *EMBO J.*, 14, 503-11. [↗](#)
- Hannon, GJ., Beach, D. (1994). p15INK4B is a potential effector of TGF-beta-induced cell cycle arrest. *Nature*, 371, 257-61. [↗](#)
- Matera, AG., Xiong, Y., Guan, KL., Nichols, MA., Li, Y., O'Keefe, CL. et al. (1994). Growth suppression by p18, a p16INK4/MTS1- and p14INK4B/MTS2-related CDK6 inhibitor, correlates with wild-type pRb function. *Genes Dev*, 8, 2939-52. [↗](#)

### Editions

2005-10-07	Edited	Matthews, L.
2006-07-10	Authored	Matthews, L.
2013-09-03	Reviewed	Samarajiwa, S.
2016-10-07	Edited	Orlic-Milacic, M.
2016-11-04	Reviewed	Roger, PP.
2019-04-23	Reviewed	Bennett, DC.

## AP-1 transcription factor binds IGFBP7 promoter ↗

**Location:** Senescence-Associated Secretory Phenotype (SASP)

**Stable identifier:** R-HSA-3797196

**Type:** binding

**Compartments:** nucleoplasm

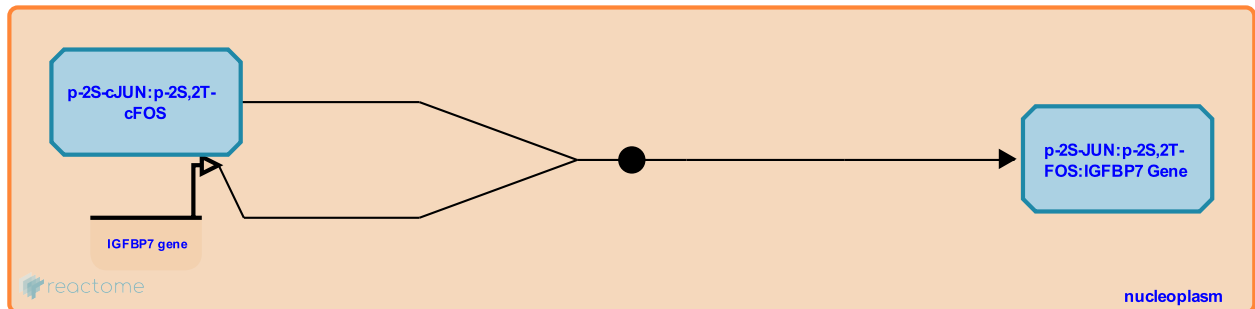

FOS:JUN (AP-1) transcription factor, formed in response to oncogenic RAF-MAPK signaling which also triggers oxidative stress, binds the promoter of IGFBP7 gene (Wajapeyee et al. 2008).

**Followed by:** [AP-1 stimulates transcription of IGFBP7](#)

### Literature references

Zhu, X., Wajapeyee, N., Serra, RW., Green, MR., Mahalingam, M. (2008). Oncogenic BRAF induces senescence and apoptosis through pathways mediated by the secreted protein IGFBP7. *Cell*, 132, 363-74. ↗

### Editions

2013-07-15	Edited	D'Eustachio, P., Matthews, L.
2013-07-15	Authored	Orlic-Milacic, M.
2013-09-03	Reviewed	Samarajiwa, S.



## AP-1 stimulates transcription of IGFBP7 ↗

**Location:** Senescence-Associated Secretory Phenotype (SASP)

**Stable identifier:** R-HSA-3797202

**Type:** omitted

**Compartments:** nucleoplasm, extracellular region

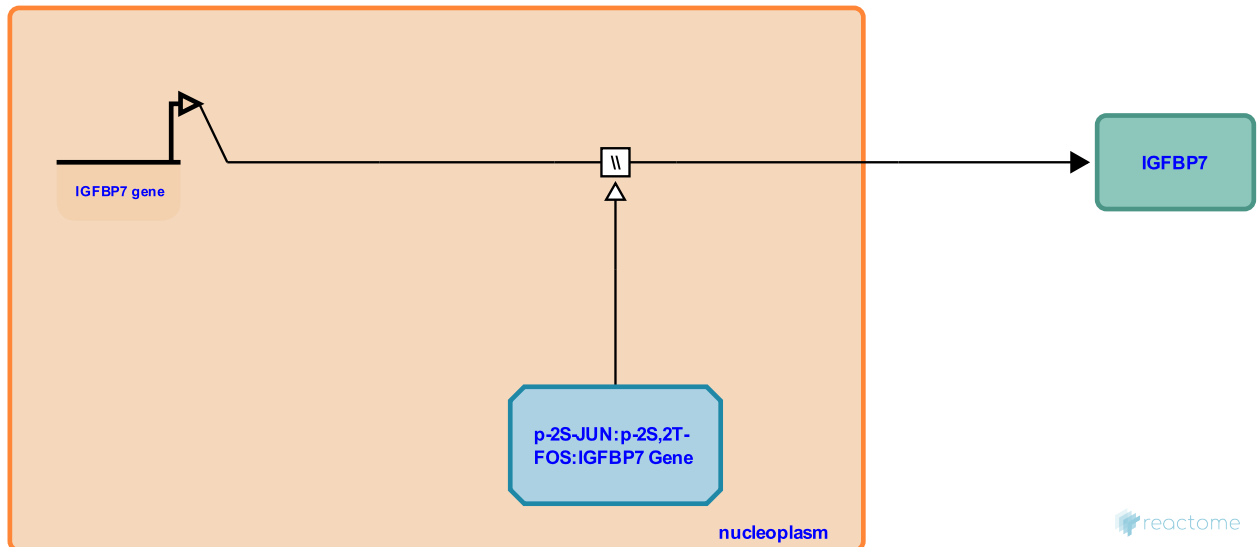

FOS:JUN (AP-1) transcription factor stimulates the transcription of IGFBP7 gene. IGFBP7 is a component of the senescence-associated secretory phenotype (SASP) and is secreted by senescent melanocytes in which the senescence is induced by the expression of oncogenic BRAF V600E. The BRAF V600E-mediated induction of IGFBP7 expression is AP-1 dependent. The conditioned medium harvested from BRAF V600E senescent melanocytes is able to inhibit cellular proliferation and induce senescence of naive melanocytes only when IGFBP7 is present in the medium (Wajapeyee et al. 2008).

**Preceded by:** AP-1 transcription factor binds IGFBP7 promoter

### Literature references

Zhu, X., Wajapeyee, N., Serra, RW., Green, MR., Mahalingam, M. (2008). Oncogenic BRAF induces senescence and apoptosis through pathways mediated by the secreted protein IGFBP7. *Cell*, 132, 363-74. ↗

### Editions

2013-07-15	Edited	D'Eustachio, P., Matthews, L.
2013-07-15	Authored	Orlic-Milacic, M.
2013-09-03	Reviewed	Samarajiwa, S.

## AP-1 transcription factor binds IL1A promoter ↗

**Location:** Senescence-Associated Secretory Phenotype (SASP)

**Stable identifier:** R-HSA-4568737

**Type:** binding

**Compartments:** nucleoplasm

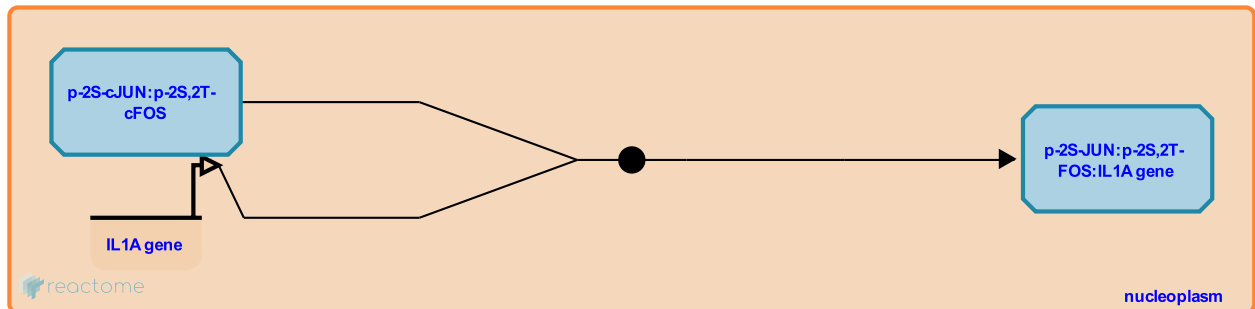

The promoter of the interleukin 1-alpha (IL1A) gene contains AP-1 binding sites which are occupied by the AP-1 (FOS:JUN) complex, resulting in the stimulation of IL1A transcription (Bailly et al. 1996, Alheim et al. 1996, Burlinson et al. 1996, Huang et al. 1999, Niu et al. 2004, Moerman-Herzog and Barger 2012, Murakami et al. 2013).

**Followed by:** [AP-1 stimulates IL1A transcription](#)

### Literature references

- Germolec, DR., Simeonova, PP., Burlinson, FG., Luster, MI. (1996). Dermatotoxic chemical stimulate of c-jun and c-fos transcription and AP-1 DNA binding in human keratinocytes. *Res. Commun. Mol. Pathol. Pharmacol.*, 93, 131-48. ↗
- Mukaida, N., Murakami, Y., Watari, K., Kuwano, M., Abe, H., Ono, M. et al. (2013). N-myc Downstream-regulated Gene 1 Promotes Tumor Inflammatory Angiogenesis through JNK Activation and Autocrine Loop of Interleukin-1? by Human Gastric Cancer Cells. *J. Biol. Chem.*, 288, 25025-37. ↗
- Niu, J., Peng, B., Li, Z., Chiao, PJ. (2004). Identification of an autoregulatory feedback pathway involving interleukin-1alpha in induction of constitutive NF-kappaB activation in pancreatic cancer cells. *J. Biol. Chem.*, 279, 16452-62. ↗
- Moerman-Herzog, AM., Barger, SW. (2012). A polymorphism in the upstream regulatory region of the interleukin-1? gene confers differential binding by transcription factors of the AP-1 family. *Life Sci.*, 90, 975-9. ↗
- Jeffrey, JJ., Huang, TT., Lan, L., Wilcox, BD., Vinci, JM. (1999). Serotonin-inducible transcription of interleukin-1alpha in uterine smooth muscle cells requires an AP-1 site: cloning and partial characterization of the rat IL-1alpha promoter. *Mol. Cell. Endocrinol.*, 152, 21-35. ↗

### Editions

2013-09-03	Reviewed	Samarajiwa, S.
2013-09-16	Authored, Edited	Orlic-Milacic, M.

## AP-1 stimulates IL1A transcription ↗

**Location:** Senescence-Associated Secretory Phenotype (SASP)

**Stable identifier:** R-HSA-4568740

**Type:** omitted

**Compartments:** nucleoplasm, extracellular region

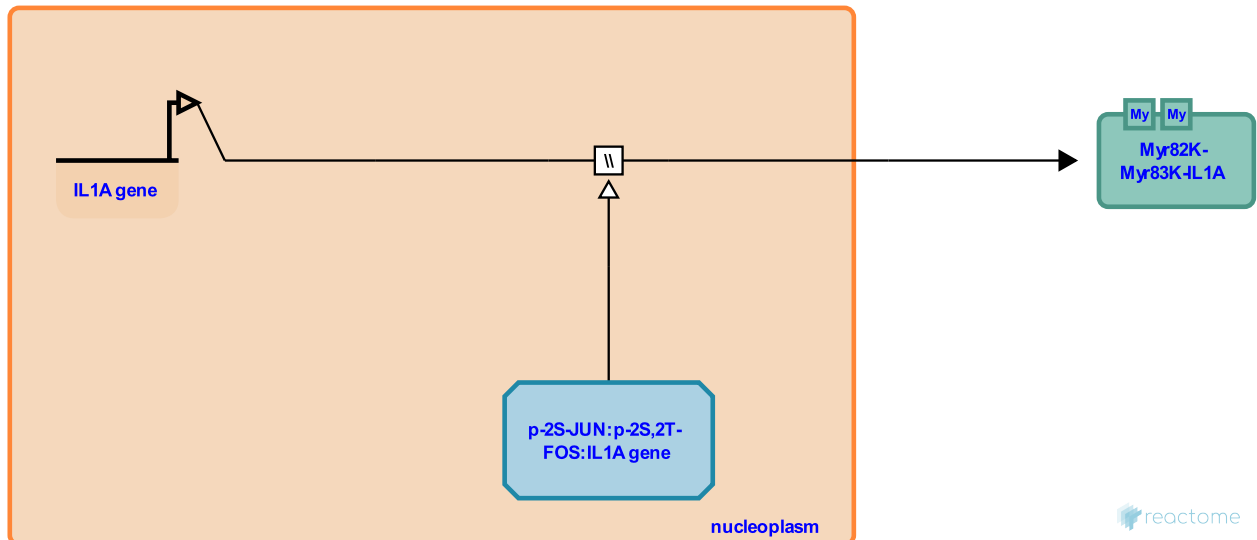

The AP-1 complex (FOS:JUN) binds IL1A promoter and stimulates IL1A transcription (Bailly et al. 1996 Alheim et al. 1996, Burleson et al. 1996, Huang et al. 1999, Niu et al. 2004, Moerman-Herzog and Barger 2012, Murakami et al. 2013).

**Preceded by:** AP-1 transcription factor binds IL1A promoter

### Literature references

- Germolec, DR., Simeonova, PP., Burleson, FG., Luster, MI. (1996). Dermatotoxic chemical stimulate of c-jun and c-fos transcription and AP-1 DNA binding in human keratinocytes. *Res. Commun. Mol. Pathol. Pharmacol.*, 93, 131-48. ↗
- Mukaida, N., Murakami, Y., Watari, K., Kuwano, M., Abe, H., Ono, M. et al. (2013). N-myc Downstream-regulated Gene 1 Promotes Tumor Inflammatory Angiogenesis through JNK Activation and Autocrine Loop of Interleukin-1? by Human Gastric Cancer Cells. *J. Biol. Chem.*, 288, 25025-37. ↗
- Niu, J., Peng, B., Li, Z., Chiao, PJ. (2004). Identification of an autoregulatory feedback pathway involving interleukin-1alpha in induction of constitutive NF-kappaB activation in pancreatic cancer cells. *J. Biol. Chem.*, 279, 16452-62. ↗
- Moerman-Herzog, AM., Barger, SW. (2012). A polymorphism in the upstream regulatory region of the interleukin-1? gene confers differential binding by transcription factors of the AP-1 family. *Life Sci.*, 90, 975-9. ↗
- Jeffrey, JJ., Huang, TT., Lan, L., Wilcox, BD., Vinci, JM. (1999). Serotonin-inducible transcription of interleukin-1alpha in uterine smooth muscle cells requires an AP-1 site: cloning and partial characterization of the rat IL-1alpha promoter. *Mol. Cell. Endocrinol.*, 152, 21-35. ↗

### Editions

2013-09-03	Reviewed	Samarajiwa, S.
2013-09-16	Authored, Edited	Orlic-Milacic, M.

# Table of Contents

Introduction	1
☒ Senescence-Associated Secretory Phenotype (SASP)	2
↳ CDKN1A (p21) prevents association of Cyclin A:Cdk2 with Cdh1	4
↳ CDKN1A (p21) prevents phosphorylation of Cdh1 by Cyclin A:Cdk2	5
↳ Cdh1:APC/C complex binds EHMT1:EHMT2	6
↳ Cdh1:APC/C ubiquitinates EHMT1 and EHMT2	7
↳ EHMT1:EHMT2 methylates IL6 promoter	8
↳ EHMT1:EHMT2 methylates IL8 promoter	9
↳ ERK1/2/5 activate RSK1/2/3	10
↳ MAPK3 (ERK1) and MAPK1 (ERK2) phosphorylate CEBPB	11
↳ RPS6KA1/2/3 phosphorylates CEBPB on S321	12
↳ CEBPB homodimerization	13
↳ Activated CEBPB and NFKB complex bind IL6 promoter	14
☒ Regulation of IL6 transcription	15
☒ Activated STAT3 positively regulates CEBPB transcription	17
↳ Activated CEBPB and NFKB complex bind IL8 promoter	18
☒ Stimulation of IL8 transcription in senescent cells	19
↳ Activated CEBPB binds CDKN2B promoter	20
☒ Activated CEBPB stimulates transcription of CDKN2B	21
↳ Association of INK4 family proteins with CDK4/6	22
↳ AP-1 transcription factor binds IGFBP7 promoter	23
☒ AP-1 stimulates transcription of IGFBP7	24
↳ AP-1 transcription factor binds IL1A promoter	25
☒ AP-1 stimulates IL1A transcription	26
Table of Contents	27