

Fc epsilon receptor (FCERI) signaling

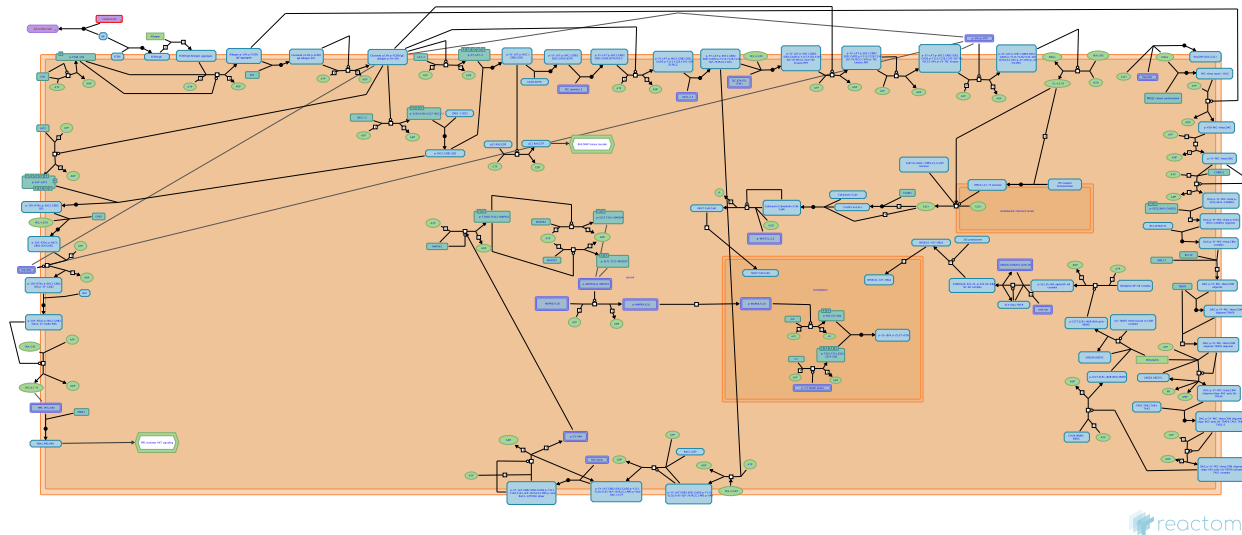

Garapati, P V., Niarakis, A., Roncagalli, R., Stephan, R.

European Bioinformatics Institute, New York University Langone Medical Center, Ontario Institute for Cancer Research, Oregon Health and Science University.

The contents of this document may be freely copied and distributed in any media, provided the authors, plus the institutions, are credited, as stated under the terms of [Creative Commons Attribution 4.0 International \(CC BY 4.0\) License](https://creativecommons.org/licenses/by/4.0/). For more information see our [license](https://creativecommons.org/licenses/by/4.0/).

Introduction

Reactome is open-source, open access, manually curated and peer-reviewed pathway database. Pathway annotations are authored by expert biologists, in collaboration with Reactome editorial staff and cross-referenced to many bioinformatics databases. A system of evidence tracking ensures that all assertions are backed up by the primary literature. Reactome is used by clinicians, geneticists, genomics researchers, and molecular biologists to interpret the results of high-throughput experimental studies, by bioinformaticians seeking to develop novel algorithms for mining knowledge from genomic studies, and by systems biologists building predictive models of normal and disease variant pathways.

The development of Reactome is supported by grants from the US National Institutes of Health (P41 HG003751), University of Toronto (CFREF Medicine by Design), European Union (EU STRP, EMI-CD), and the European Molecular Biology Laboratory (EBI Industry program).

Literature references

- Fabregat, A., Sidiropoulos, K., Viteri, G., Forner, O., Marin-Garcia, P., Arnau, V. et al. (2017). Reactome pathway analysis: a high-performance in-memory approach. *BMC bioinformatics*, 18, 142. [↗](#)
- Sidiropoulos, K., Viteri, G., Sevilla, C., Jupe, S., Webber, M., Orlic-Milacic, M. et al. (2017). Reactome enhanced pathway visualization. *Bioinformatics*, 33, 3461-3467. [↗](#)
- Fabregat, A., Jupe, S., Matthews, L., Sidiropoulos, K., Gillespie, M., Garapati, P. et al. (2018). The Reactome Pathway Knowledgebase. *Nucleic Acids Res*, 46, D649-D655. [↗](#)
- Fabregat, A., Korninger, F., Viteri, G., Sidiropoulos, K., Marin-Garcia, P., Ping, P. et al. (2018). Reactome graph database: Efficient access to complex pathway data. *PLoS computational biology*, 14, e1005968. [↗](#)

Reactome database release: 77

This document contains 5 pathways and 8 reactions ([see Table of Contents](#))

Fc epsilon receptor (FCERI) signaling ↗

Stable identifier: R-HSA-2454202

Compartments: plasma membrane

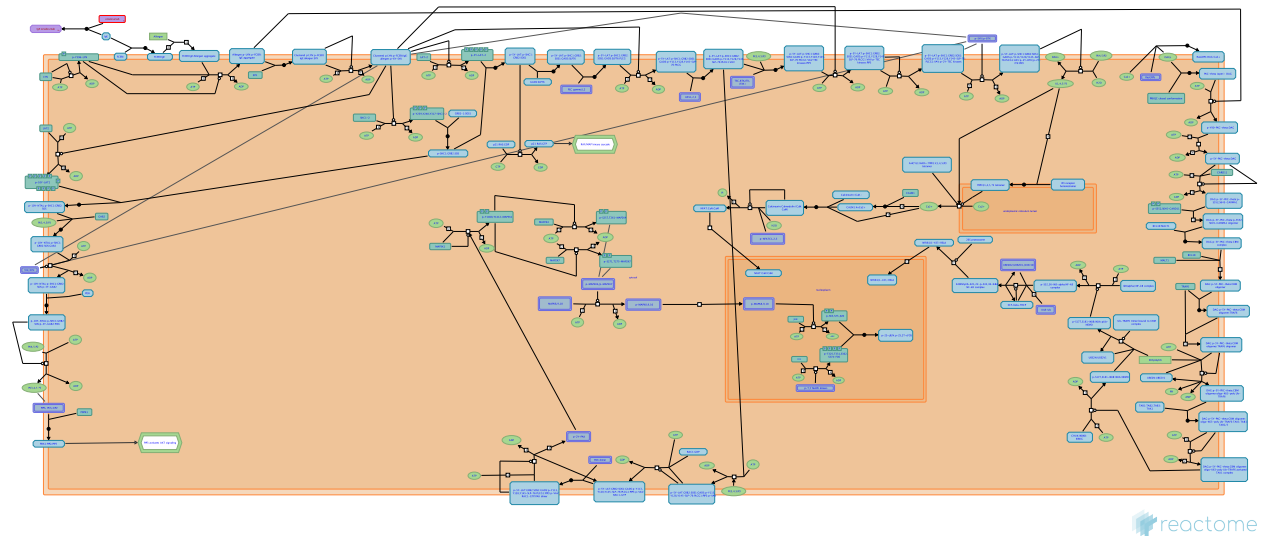

Mast cells (MC) are distributed in tissues throughout the human body and have long been recognized as key cells of type I hypersensitivity reactions. They also play important roles in inflammatory and immediate allergic reactions. Activation through FCERI-bound antigen-specific IgE causes release of potent inflammatory mediators, such as histamine, proteases, chemotactic factors, cytokines and metabolites of arachidonic acid that act on the vasculature, smooth muscle, connective tissue, mucous glands and inflammatory cells (Borish & Joseph 1992, Amin 2012, Metcalfe et al. 1993). FCERI is a multimeric cell-surface receptor that binds the Fc fragment of IgE with high affinity. On mast cells and basophils FCERI exists as a tetrameric complex consisting of one alpha-chain, one beta-chain, and two disulfide-bonded gamma-chains, and on dendritic cells, Langerhans cells, macrophages, and eosinophils it exists as a trimeric complex with one alpha-chain and two disulfide-bonded gamma-chains (Wu 2011, Kraft & Kinet 2007). FCERI signaling in mast cells includes a network of signaling molecules and adaptor proteins. These molecules coordinate ultimately leading to effects on degranulation, eicosanoid production, and cytokine and chemokine production and cell migration and adhesion, growth and survival.

The first step in FCERI signaling is the phosphorylation of the tyrosine residues in the ITAM of both the beta and the gamma subunits of the FCERI by LYN, which is bound to the FCERI beta-chain. The phosphorylated ITAM then recruits the protein tyrosine kinase SYK (spleen tyrosine kinase) which then phosphorylates the adaptor protein LAT. Phosphorylated LAT (linker for activation of T cells) acts as a scaffolding protein and recruits other cytosolic adaptor molecules GRB2 (growth-factor-receptor-bound protein 2), GADS (GRB2-related adaptor protein), SHC (SRC homology 2 (SH2)-domain-containing transforming protein C) and SLP76 (SH2-domain-containing leukocyte protein of 76 kDa), as well as the exchange factors and adaptor molecules VAV and SOS (son of sevenless homologue), and the signalling enzyme phospholipase C gamma1 (PLC-gamma1). Tyrosine phosphorylation of enzymes and adaptors, including VAV, SHC GRB2 and SOS stimulate small GTPases such as RAC, RAS and RAF. These pathways lead to activation of the ERK, JNK and p38 MAP kinases, histamine release and cytokine production. FCERI activation also triggers the phosphorylation of PLC-gamma which upon membrane localisation hydrolyse PIP2 to form IP3 and 1,2-diacylglycerol (DAG) - second messengers that release Ca²⁺ from internal stores and activate PKC, respectively. Degranulation or histamine release follows the activation of PLC-gamma and protein kinase C (PKC) and the increased mobilization of calcium (Ca²⁺). Receptor aggregation also results in the phosphorylation of adaptor protein NTAL/LAT2 which then recruits GAB2. PI3K associates

with phosphorylated GAB2 and catalyses the formation of PIP3 in the membrane, which attracts many PH domain proteins like BTK, PLC-gamma, AKT and PDK. PI3K mediated activation of AKT then regulate the mast cell proliferation, development and survival (Gu et al. 2001).

Literature references

Wu, LC. (2011). Immunoglobulin E receptor signaling and asthma. *J. Biol. Chem.*, 286, 32891-7. [↗](#)

Blank, U., Rivera, J. (2004). The ins and outs of IgE-dependent mast-cell exocytosis. *Trends Immunol.*, 25, 266-73. [↗](#)

Editions

2012-08-22	Edited	Garapati, P V.
2012-12-21	Authored	Niarakis, A.
2013-02-13	Reviewed	Roncagalli, R.

IgE binds FCERI ↗

Location: [Fc epsilon receptor \(FCERI\) signaling](#)

Stable identifier: R-HSA-9725206

Type: binding

Compartments: extracellular region, plasma membrane

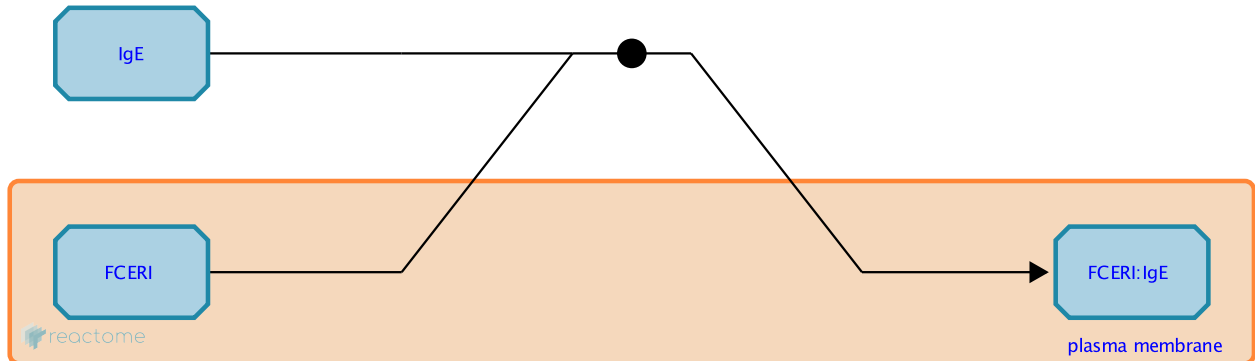

Immunoglobulin-E (IgE)-mediated allergic responses require the binding of the IgE antibody to its high-affinity receptor, Fc epsilonRI (FCERI). Binding of one receptor blocks the binding of a second receptor. After this antigens can bind and crosslink IgE molecules held at the cell surface by FCERI (Garman et al. 2000).

Followed by: [Allergen dependent IgE bound FCERI aggregation](#)

Literature references

Garman, SC., Wurzburg, BA., Tarchevskaya, SS., Kinet, JP., Jardetzky, TS. (2000). Structure of the Fc fragment of human IgE bound to its high-affinity receptor Fc epsilonRI alpha. *Nature*, 406, 259-66. ↗

Editions

2021-03-29	Authored, Edited	Stephan, R.
2021-03-31	Reviewed	Niarakis, A.

IgE binds omalizumab ↗

Location: Fc epsilon receptor (FCERI) signaling

Stable identifier: R-HSA-9724685

Type: binding

Compartments: extracellular region

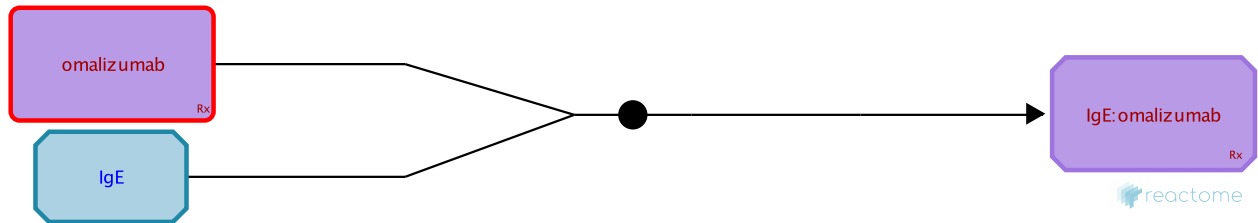

When bound to the high-affinity IgE receptor (FCERI), IgE acts as an environmental sensor that detects allergens and induces allergic responses from the cell's interior. Omalizumab is a monoclonal antibody that binds free IgE preventing it from binding to FCERI. Moreover, reduction of free IgE concentrations reduce FCERI expression level. Omalizumab is approved for the treatment of patients with severe allergic asthma. Use of omalizumab is associated with several side effects, including injection site reactions, viral and upper respiratory tract infections, headache, sinusitis, and pharyngitis. The main severe adverse effect is anaphylactic shock, with a rate of occurrence of 1 to 2 patients per 1,000 (Davydov 2005, Arm et al. 2014).

Literature references

Arm, JP., Bottoli, I., Skerjanec, A., Floch, D., Groenewegen, A., Maahs, S. et al. (2014). Pharmacokinetics, pharmacodynamics and safety of QGE031 (ligelizumab), a novel high-affinity anti-IgE antibody, in atopic subjects. *Clin. Exp. Allergy*, 44, 1371-85. ↗

Davydov, L. (2005). Omalizumab (Xolair) for treatment of asthma. *Am Fam Physician*, 71, 341-2. ↗

Editions

2021-03-29	Authored, Edited	Stephan, R.
2021-03-31	Reviewed	Niarakis, A.

Allergen dependent IgE bound FCERI aggregation ↗

Location: [Fc epsilon receptor \(FCERI\) signaling](#)

Stable identifier: R-HSA-2454192

Type: omitted

Compartments: plasma membrane, extracellular region

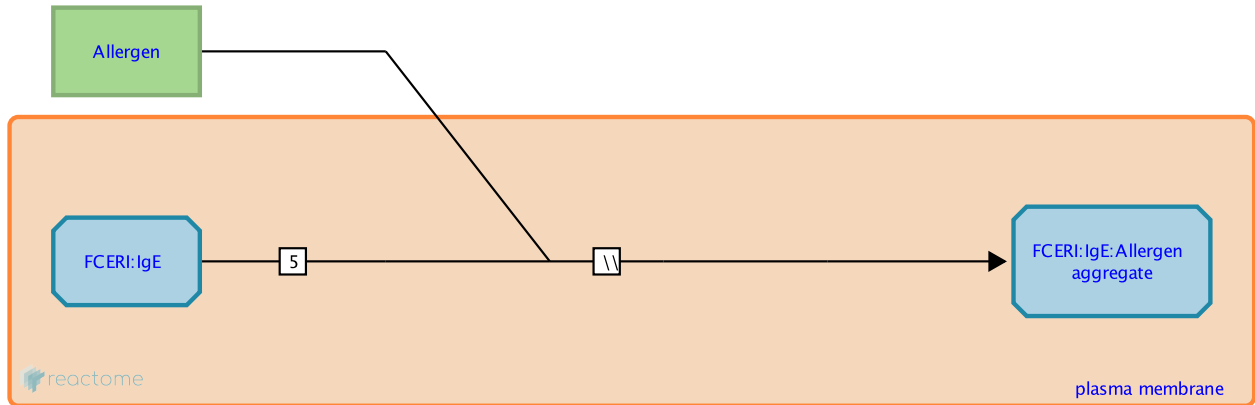

FCERI is primarily expressed on mast cells and basophils as a tetrameric complex comprising an IgE-binding alpha subunit, a signal amplifying membrane-tetraspanning beta subunit, and a disulfide-linked gamma chain dimer that provides the receptor its signaling competence (Blank & Rivera 2004). In the absence of an antigen or allergen, FCERI receptor binds to monomeric IgE antibodies, and thus the receptor adopts the antigenic specificity of the prevalent IgE repertoire (Garman et al. 2000). Mast cell activation is initiated when multivalent antigen crosslinks the IgE bound to the high-affinity FCERI, thereby aggregating FCERI (Siraganian 2003). Antigen driven aggregation of FCERI then elicits intracellular signals that result in mast cell exocytosis.

Preceded by: [IgE binds FCERI](#)

Followed by: [Phosphorylation of beta and gamma subunits by LYN](#)

Literature references

Garman, SC., Wurzburg, BA., Tarchevskaya, SS., Kinet, JP., Jardetzky, TS. (2000). Structure of the Fc fragment of human IgE bound to its high-affinity receptor Fc epsilonRI alpha. *Nature*, 406, 259-66. ↗

Siraganian, RP. (2003). Mast cell signal transduction from the high-affinity IgE receptor. *Curr. Opin. Immunol.*, 15, 639-46. ↗

Holowka, D., Sil, D., Torigoe, C., Baird, B. (2007). Insights into immunoglobulin E receptor signaling from structurally defined ligands. *Immunol. Rev.*, 217, 269-79. ↗

Editions

2012-08-22	Edited	Garapati, P V.
2012-12-21	Authored	Niarakis, A.
2013-02-13	Reviewed	Roncagalli, R.

Autophosphorylation of LYN kinase ↗

Location: Fc epsilon receptor (FCER1) signaling

Stable identifier: R-HSA-2730862

Type: transition

Compartments: plasma membrane, cytosol

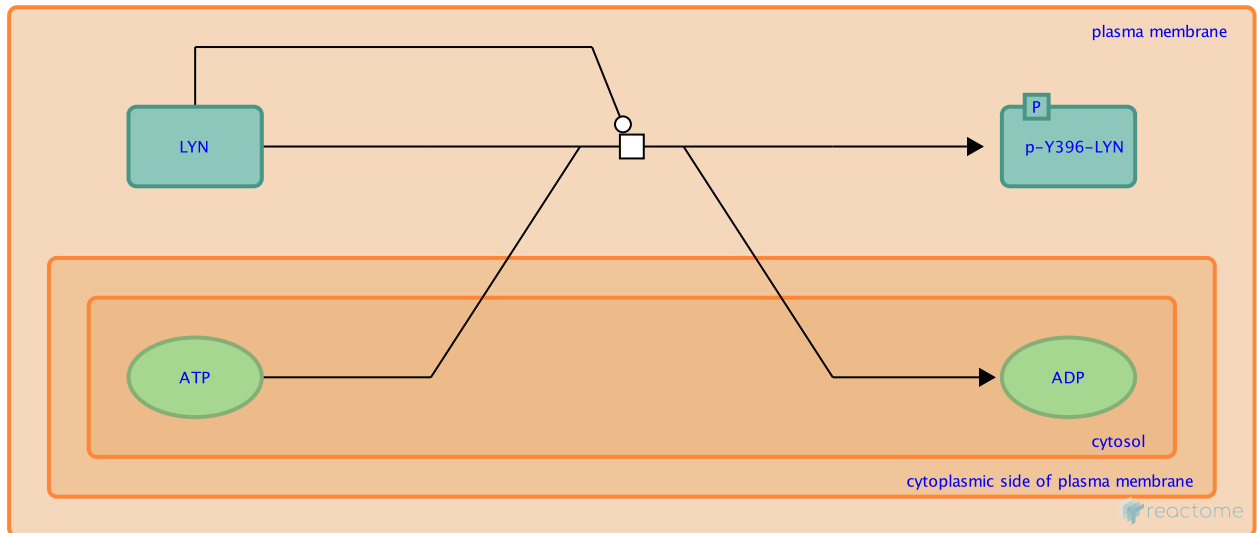

LYN localized in lipid rafts undergoes an intermolecular autophosphorylation at tyrosine 396. This residue is present in the activation loop, and its phosphorylation promotes LYN kinase activity.

Followed by: Phosphorylation of beta and gamma subunits by LYN

Literature references

Donella-Deana, A., Cesaro, L., Ruzzene, M., Brunati, AM., Marin, O., Pinna, LA. (1998). Spontaneous autophosphorylation of Lyn tyrosine kinase at both its activation segment and C-terminal tail confers altered substrate specificity. *Biochemistry*, 37, 1438-46. ↗

Editions

2012-08-22	Edited	Garapati, P V.
2012-12-21	Authored	Niarakis, A.
2013-02-13	Reviewed	Roncagalli, R.

Phosphorylation of beta and gamma subunits by LYN ↗

Location: Fc epsilon receptor (FCERI) signaling

Stable identifier: R-HSA-2454208

Type: transition

Compartments: plasma membrane, cytosol

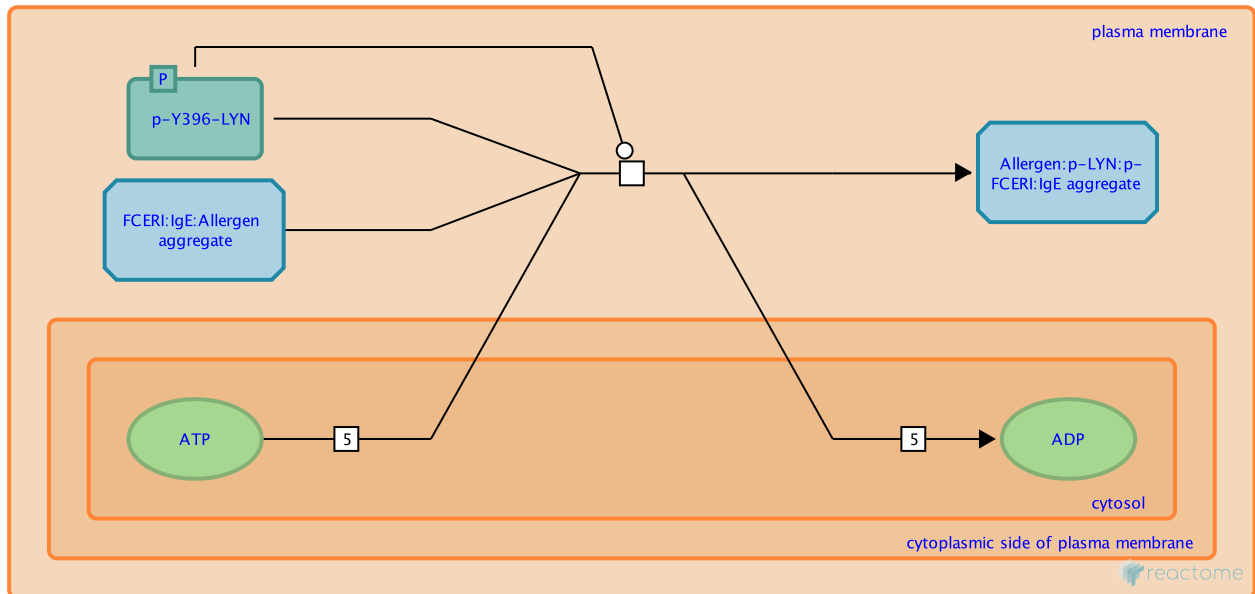

Upon FCGRI-IgE aggregation, LYN kinase phosphorylates the tyrosine residues within the ITAM (immunoreceptor tyrosine-based activation motifs) of both the beta and gamma subunits. The detailed mechanism of the initial engagement of LYN kinase and FCERI is incompletely understood, but two different models have been proposed. One model postulates that a small fraction of LYN is constitutively bound to beta subunit of FCERI prior to activation. Aggregation of FCERI facilitates the transphosphorylation of one FCERI by LYN bound to a juxtaposed receptor (Vonakis et al. 1997, Draber & Draberova 2002). Alternative model postulates that LYN is observed in lipid rafts enriched in glycosphingolipids, cholesterol, and glycosylphosphatidylinositol-anchored proteins and upon aggregation, FCERI rapidly translocates into lipid rafts, where it is phosphorylated by LYN kinase. Either the association of LYN or FCERI or both with lipid rafts is important for initiating this phosphorylation process (Young et al. 2003, Kovarova et al. 2002, Draber & Draberova 2002).

Beta subunit ITAM differs from canonical ITAMs in two ways; the spacing between the two canonical tyrosines harbours a third tyrosine, and it is one amino acid shorter than in canonical ITAMs, thus making it unfit to bind and recruit Syk. Among the three tyrosine residues (Y219, Y225 and Y229), Y219 may play a predominant role in beta chain function and LYN recruitment. Mutation of this tyrosine would decrease substantially LYN association and subsequent phosphorylation of Y225 and Y229. This would result in decreased gamma phosphorylation and decreased SYK recruitment and activation (On et al. 2004).

Preceded by: Autophosphorylation of LYN kinase, Allergen dependent IgE bound FCERI aggregation

Followed by: Recruitment of SYK to p-FCERI gamma subunit

Literature references

Kovárová, M., Tolar, P., Arudchandran, R., Dráberová, L., Rivera, J., Dráber, P. (2001). Structure-function analysis of Lyn kinase association with lipid rafts and initiation of early signaling events after Fc epsilon receptor I aggregation. *Mol. Cell. Biol.*, 21, 8318-28. ↗

Young, RM., Holowka, D., Baird, B. (2003). A lipid raft environment enhances Lyn kinase activity by protecting the active site tyrosine from dephosphorylation. *J. Biol. Chem.*, 278, 20746-52. [↗](#)

Vonakis, BM., Chen, H., Haleem-Smith, H., Metzger, H. (1997). The unique domain as the site on Lyn kinase for its constitutive association with the high affinity receptor for IgE. *J. Biol. Chem.*, 272, 24072-80. [↗](#)

Pribluda, VS., Pribluda, C., Metzger, H. (1994). Transphosphorylation as the mechanism by which the high-affinity receptor for IgE is phosphorylated upon aggregation. *Proc. Natl. Acad. Sci. U.S.A.*, 91, 11246-50. [↗](#)

Dráber, P., Dráberová, L. (2002). Lipid rafts in mast cell signaling. *Mol. Immunol.*, 38, 1247-52. [↗](#)

Editions

2012-08-22	Edited	Garapati, P V.
2012-12-21	Authored	Niarakis, A.
2013-02-13	Reviewed	Roncagalli, R.

Recruitment of SYK to p-FCERI gamma subunit ↗

Location: [Fc epsilon receptor \(FCERI\) signaling](#)

Stable identifier: R-HSA-2454240

Type: binding

Compartments: plasma membrane, cytosol

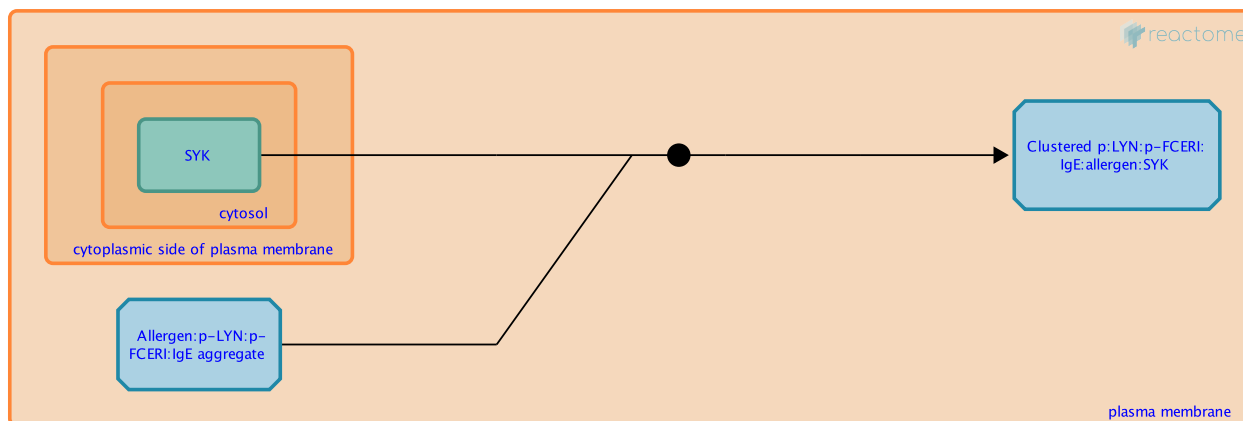

Tyrosine phosphorylated ITAM in FCERI gamma subunit serves as docking site for SYK (spleen tyrosine kinases), whereas the beta-subunit ITAM has an extra tyrosine and is shorter than canonical ITAM which makes it unfit to bind SYK. Association of SYK to FCERI gamma-subunit disrupts the COOH-terminal-SH2 interdomain interaction of SYK causing a conformational change opening the molecule leading to its activation (Siraganian et al. 2010, de Castro et al. 2010).

Preceded by: [Phosphorylation of beta and gamma subunits by LYN](#)

Followed by: [Phosphorylation of SYK](#)

Literature references

- Kimura, T., Kihara, H., Bhattacharyya, S., Sakamoto, H., Appella, E., Siraganian, RP. (1996). Downstream signaling molecules bind to different phosphorylated immunoreceptor tyrosine-based activation motif (ITAM) peptides of the high affinity IgE receptor. *J. Biol. Chem.*, 271, 27962-8. ↗
- Kihara, H., Siraganian, RP. (1994). Src homology 2 domains of Syk and Lyn bind to tyrosine-phosphorylated subunits of the high affinity IgE receptor. *J. Biol. Chem.*, 269, 22427-32. ↗
- Shiue, L., Green, J., Green, OM., Karas, JL., Morgenstern, JP., Ram, MK. et al. (1995). Interaction of p72syk with the gamma and beta subunits of the high-affinity receptor for immunoglobulin E, Fc epsilon RI. *Mol. Cell. Biol.*, 15, 272-81. ↗

Editions

2012-08-22	Edited	Garapati, P V.
2012-12-21	Authored	Niarakis, A.
2013-02-13	Reviewed	Roncagalli, R.

Phosphorylation of SYK ↗

Location: Fc epsilon receptor (FCERI) signaling

Stable identifier: R-HSA-2454239

Type: transition

Compartments: plasma membrane, cytosol

Inferred from: Phosphorylation of syk (Rattus norvegicus)

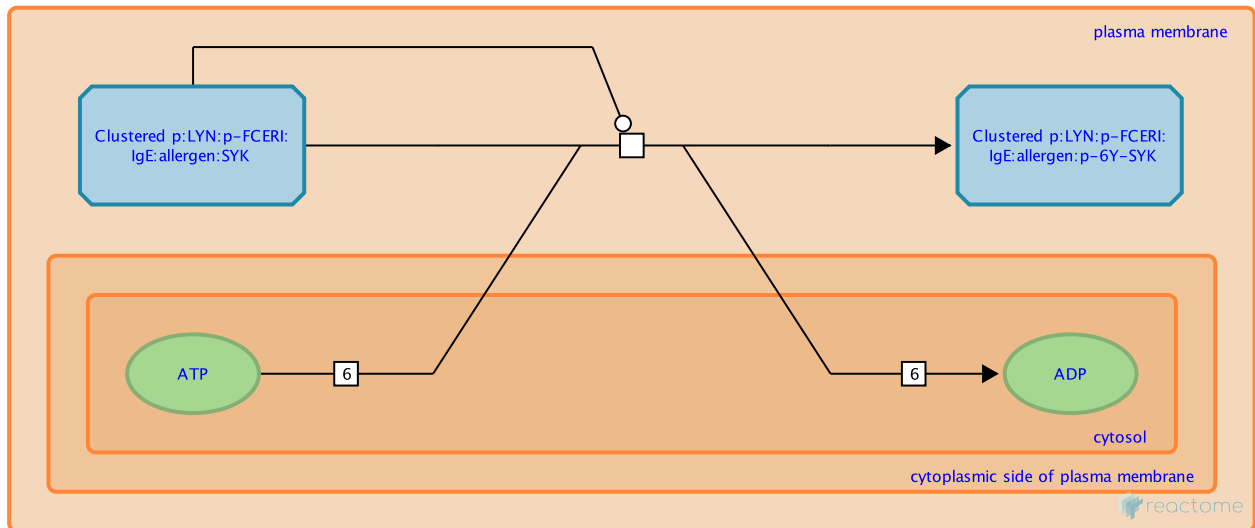

Multiple sites of phosphorylation are known to exist in SYK, which both regulate its activity and also serve as docking sites for other proteins. Some of these sites include Y131 of interdomain A, Y323, Y348, and Y352 of interdomain B, and Y525 and Y526 within the activation loop of the kinase domain and Y630 in the C-terminus (Zhang et al. 2002, Lupher et al. 1998, Furlong et al. 1997). Phosphorylation of these tyrosine residues disrupts autoinhibitory interactions and results in kinase activation even in the absence of phosphorylated ITAM tyrosines (Tsang et al. 2008). SYK is primarily phosphorylated by Src family kinases and this acts as an initiating trigger by generating few molecules of activated SYK which are then involved in major SYK autophosphorylation (Hillal et al. 1997).

Preceded by: Recruitment of SYK to p-FCERI gamma subunit

Followed by: Phosphorylation of LAT by p-SYK

Editions

2012-08-22	Edited	Garapati, P V.
2012-12-21	Authored	Niarakis, A.
2013-02-13	Reviewed	Roncagalli, R.

Phosphorylation of LAT by p-SYK ↗

Location: Fc epsilon receptor (FCERI) signaling

Stable identifier: R-HSA-2730843

Type: transition

Compartments: plasma membrane, cytosol

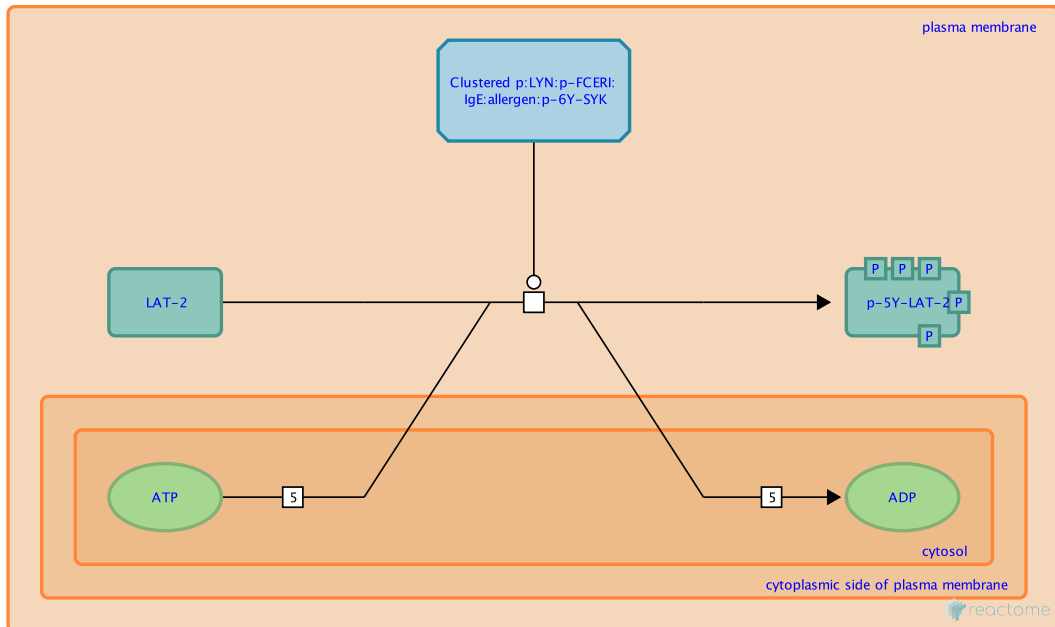

LAT is palmitoylated and membrane-associated adaptor protein. It rapidly becomes tyrosine-phosphorylated upon receptor engagement. LAT has nine conserved tyrosine residues of which five have been shown to undergo phosphorylation (Y127, Y132, Y171, Y191 and Y226). Src family kinases, SYK and ZAP-70 efficiently phosphorylate LAT on these tyrosine residues (Jiang & Cheng 2007, Paz et al. 2001). Phosphorylation of LAT creates binding sites for the Src homology 2 (SH2) domain proteins PLC-gamma1, GRB2 and GADS, which indirectly bind SOS, VAV, SLP-76 and ITK (Wange 2000).

Preceded by: Phosphorylation of SYK

Literature references

Jiang, Y., Cheng, H. (2007). Evidence of LAT as a dual substrate for Lck and Syk in T lymphocytes. *Leuk Res*, 31, 541-5. ↗

Paz, PE., Wang, S., Clarke, H., Lu, X., Stokoe, D., Abo, A. (2001). Mapping the Zap-70 phosphorylation sites on LAT (linker for activation of T cells) required for recruitment and activation of signalling proteins in T cells. *Biochem. J.*, 356, 461-71. ↗

Jevremovic, D., Billadeau, DD., Schoon, RA., Dick, CJ., Irvin, BJ., Zhang, W. et al. (1999). Cutting edge: a role for the adaptor protein LAT in human NK cell-mediated cytotoxicity. *J. Immunol.*, 162, 2453-6. ↗

Editions

2012-08-22	Edited	Garapati, P V.
2012-12-21	Authored	Niarakis, A.
2013-02-13	Reviewed	Roncagalli, R.

FCERI mediated MAPK activation ↗

Location: Fc epsilon receptor (FCERI) signaling

Stable identifier: R-HSA-2871796

Compartments: cytosol, nucleoplasm, plasma membrane

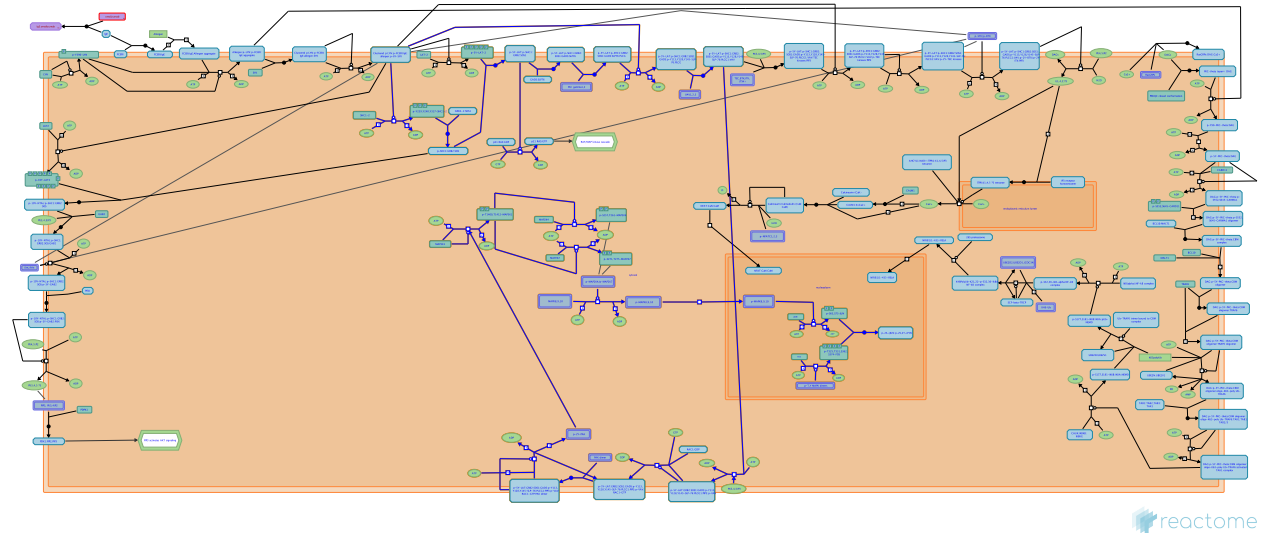

Formation of the LAT signaling complex leads to activation of MAPK and production of cytokines. The sequence of events that leads from LAT to cytokine production has not been as clearly defined as the sequence that leads to degranulation. However, the pathways that lead to cytokine production require the guanine-nucleotide-exchange factors SOS and VAV that regulate GDP-GTP exchange of RAS. After its activation, RAS positively regulates the RAF-dependent pathway that leads to phosphorylation and, in part, activation of the mitogen-activated protein kinases (MAPKs) extracellular-signal-regulated kinase 1 (ERK1) and ERK2 (Gilfillan & Tkaczyk 2006).

Literature references

Alvarez-Errico, D., Lessmann, E., Rivera, J. (2009). Adapters in the organization of mast cell signaling. *Immunol. Rev.*, 232, 195-217. ↗

Gilfillan, AM., Rivera, J. (2009). The tyrosine kinase network regulating mast cell activation. *Immunol. Rev.*, 228, 149-69. ↗

Kope?, A., Panaszek, B., Fal, AM. (2006). Intracellular signaling pathways in IgE-dependent mast cell activation. *Arch. Immunol. Ther. Exp. (Warsz.)*, 54, 393-401. ↗

Editions

2012-08-22	Edited	Garapati, P V.
2012-12-21	Authored	Niarakis, A.
2013-02-13	Reviewed	Roncagalli, R.

FCERI mediated Ca²⁺ mobilization ↗

Location: Fc epsilon receptor (FCERI) signaling

Stable identifier: R-HSA-2871809

Compartments: cytosol, plasma membrane, nucleoplasm

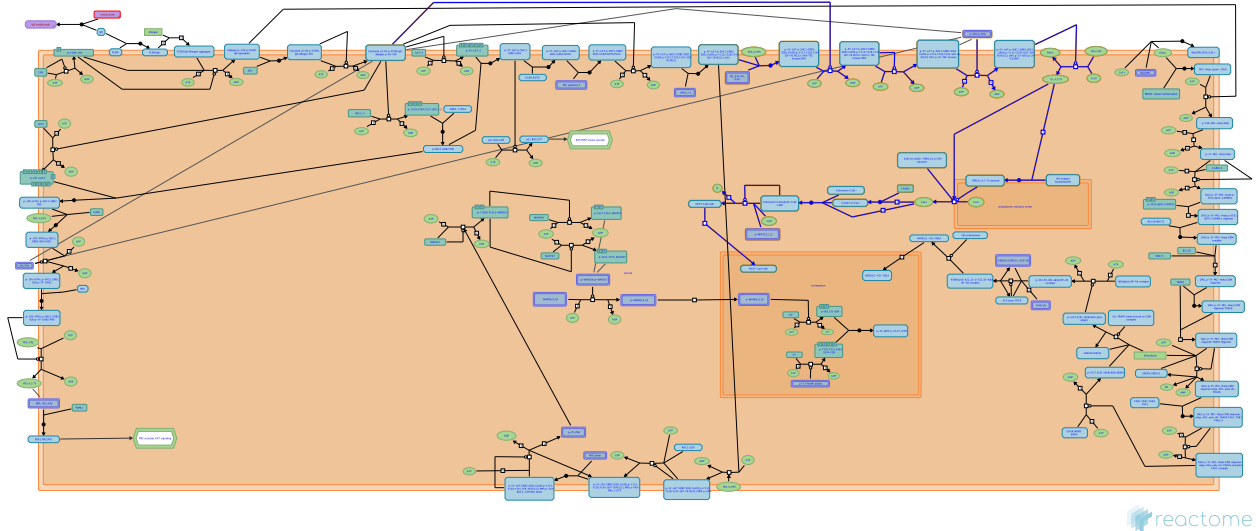

Increase of intracellular calcium in mast cells is most crucial for mast cell degranulation. Elevation of intracellular calcium is achieved by activation of PLC-gamma. Mast cells express both PLC-gamma1 and PLC-gamma2 isoforms and activation of these enzymes leads to conversion of phosphatidylinositol 4,5-bisphosphate (PIP₂) into inositol triphosphate (IP₃) and diacylglycerol (DAG). The production of IP₃ leads to mobilization of intracellular Ca²⁺, which later results in a sustained Ca²⁺ flux response that is maintained by an influx of extracellular Ca²⁺. In addition to degranulation, an increase in intracellular calcium concentration also activates the Ca²⁺/calmodulin-dependent serine phosphatase calcineurin. Calcineurin dephosphorylates the nuclear factor for T cell activation (NFAT) which exposes nuclear-localization signal sequence triggering translocation of the dephosphorylated NFAT-Ca_N complex to the nucleus. Once in the nucleus, NFAT regulates the transcription of several cytokine genes (Kambayashi et al. 2007, Hoth & Penner 1992, Ebinu et al. 2000, Siraganian et al).

Literature references

- Hoth, M., Penner, R. (1992). Depletion of intracellular calcium stores activates a calcium current in mast cells. *Nature*, 355, 353-6. ↗
- Kambayashi, T., Koretzky, GA. (2007). Proximal signaling events in Fc epsilon RI-mediated mast cell activation. *J. Allergy Clin. Immunol.*, 119, 544-52; quiz 553-4. ↗
- Ebinu, JO., Stang, SL., Teixeira, C., Bottorff, DA., Hooton, J., Blumberg, PM. et al. (2000). RasGRP links T-cell receptor signaling to Ras. *Blood*, 95, 3199-203. ↗

Editions

2012-08-22	Edited	Garapati, P V.
2012-12-21	Authored	Niarakis, A.
2013-02-13	Reviewed	Roncagalli, R.

FCERI mediated NF-kB activation ↗

Location: Fc epsilon receptor (FCERI) signaling

Stable identifier: R-HSA-2871837

Compartments: cytosol, nucleoplasm, plasma membrane

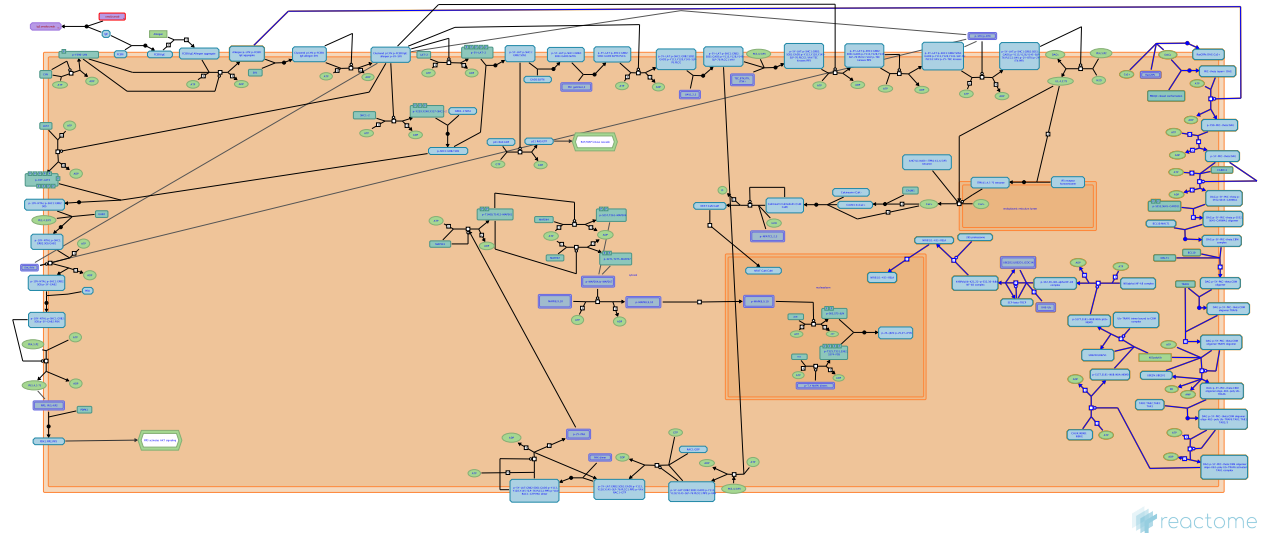

The increase in intracellular Ca^{2+} in conjunction with DAG also activates PKC and RasGRP, which in turn contributes to cytokine production by mast cells (Kambayashi et al. 2007). Activation of the FCERI engages CARMA1, BCL10 and MALT1 complex to activate NF- κ B through PKC- θ (Klemm et al. 2006, Chen et al. 2007). FCERI stimulation leads to phosphorylation, and degradation of I κ B which allows the release and nuclear translocation of the NF- κ B proteins. Activation of the NF- κ B transcription factors then results in the synthesis of several cytokines. NF- κ B activation by FCERI is critical for proinflammatory cytokine production during mast cell activation and is crucial for allergic inflammatory diseases (Klemm et al. 2006).

Literature references

- Kambayashi, T., Koretzky, GA. (2007). Proximal signaling events in Fc epsilon RI-mediated mast cell activation. *J. Allergy Clin. Immunol.*, 119, 544-52; quiz 553-4. ↗
- Klemm, S., Gutermuth, J., Hültner, L., Sparwasser, T., Behrendt, H., Peschel, C. et al. (2006). The Bcl10-Malt1 complex segregates Fc epsilon RI-mediated nuclear factor kappa B activation and cytokine production from mast cell degranulation. *J. Exp. Med.*, 203, 337-47. ↗

Editions

2012-08-22	Edited	Garapati, P V.
2012-12-21	Authored	Niarakis, A.
2013-02-13	Reviewed	Roncagalli, R.

Role of LAT2/NTAL/LAB on calcium mobilization ↗

Location: Fc epsilon receptor (FCERI) signaling

Stable identifier: R-HSA-2730905

Compartments: cytosol, plasma membrane

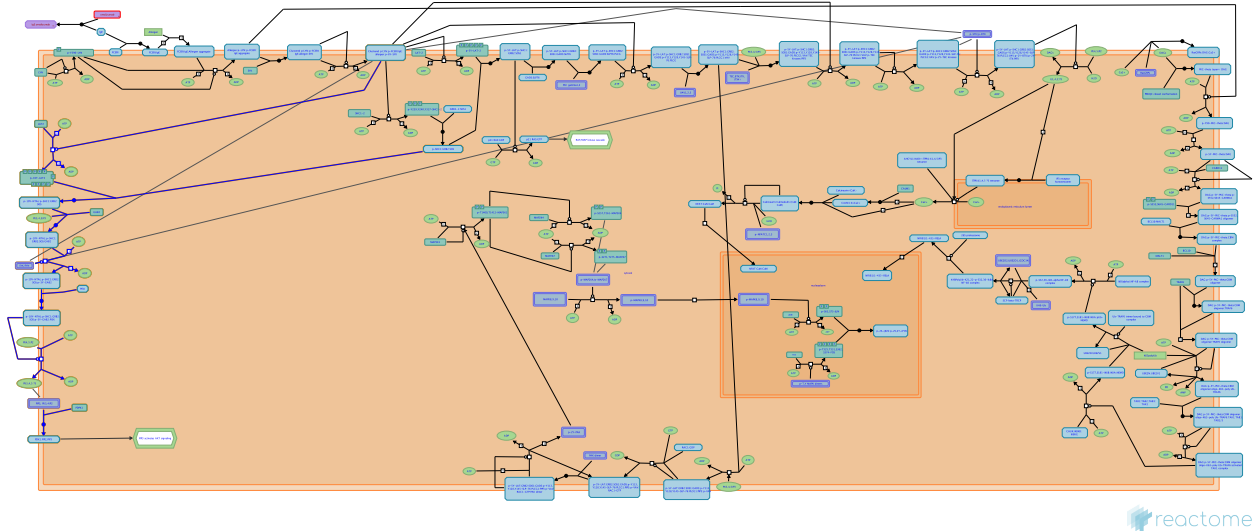

The lipid raft resident adaptor molecules LAT1 and Non-T cell activation linker (NTAL), also known as linker for activation of B cells (LAB)/LAT2 are known participants in the regulation of mast cell calcium responses. Both LAT and NTAL are expressed and phosphorylated following engagement of FCERI on mast cells. NTAL is functionally and topographically different from LAT. There is a considerable debate on the role of NTAL in mast cell. Depending on the circumstances, NTAL appears to have a dual role as positive and negative regulator of MC responses elicited via FCERI. Studies conducted in bone marrow-derived mast cells (BMMCs) of mice lacking NTAL displayed enhanced FCERI-mediated tyrosine phosphorylation of several substrates, calcium response, degranulation, and cytokine production. This indicated that NTAL negatively regulates FCERI-mediated degranulation. However, in mice lacking both LAT and NTAL showed severe block in FCERI-mediated signaling than BMMCs deficient in LAT alone, suggesting that NTAL also shares a redundant function with LAT to play a positive role (Draberova et al. 2007, Orr & McVicar. 2011, Zhu et al. 2004, Volna et al. 2004). The major steps in NTAL mediated Ca²⁺ influx involves NTAL--> GAB2--> PI3K

Literature references

- Yamasaki, S., Ishikawa, E., Sakuma, M., Kanagawa, O., Cheng, AM., Malissen, B. et al. (2007). LAT and NTAL mediate immunoglobulin E-induced sustained extracellular signal-regulated kinase activation critical for mast cell survival. *Mol. Cell. Biol.*, 27, 4406-15. ↗
- Iwaki, S., Spicka, J., Tkaczyk, C., Jensen, BM., Furumoto, Y., Charles, N. et al. (2008). Kit- and Fc epsilonRI-induced differential phosphorylation of the transmembrane adaptor molecule NTAL/LAB/LAT2 allows flexibility in its scaffolding function in mast cells. *Cell. Signal.*, 20, 195-205. ↗
- Orr, SJ., McVicar, DW. (2011). LAB/NTAL/Lat2: a force to be reckoned with in all leukocytes?. *J. Leukoc. Biol.*, 89, 11-9. ↗

Editions

2012-08-22	Edited	Garapati, P V.
2012-12-21	Authored	Niarakis, A.
2013-02-13	Reviewed	Roncagalli, R.

Table of Contents

Introduction	1
❏ Fc epsilon receptor (FCER1) signaling	2
↳ IgE binds FCER1	4
↳ IgE binds omalizumab	5
❏ Allergen dependent IgE bound FCER1 aggregation	6
↳ Autophosphorylation of LYN kinase	7
↳ Phosphorylation of beta and gamma subunits by LYN	8
↳ Recruitment of SYK to p-FCER1 gamma subunit	10
↳ Phosphorylation of SYK	11
↳ Phosphorylation of LAT by p-SYK	12
❏ FCER1 mediated MAPK activation	13
❏ FCER1 mediated Ca ²⁺ mobilization	14
❏ FCER1 mediated NF-kB activation	15
❏ Role of LAT2/NTAL/LAB on calcium mobilization	16
Table of Contents	17