

# Pexophagy

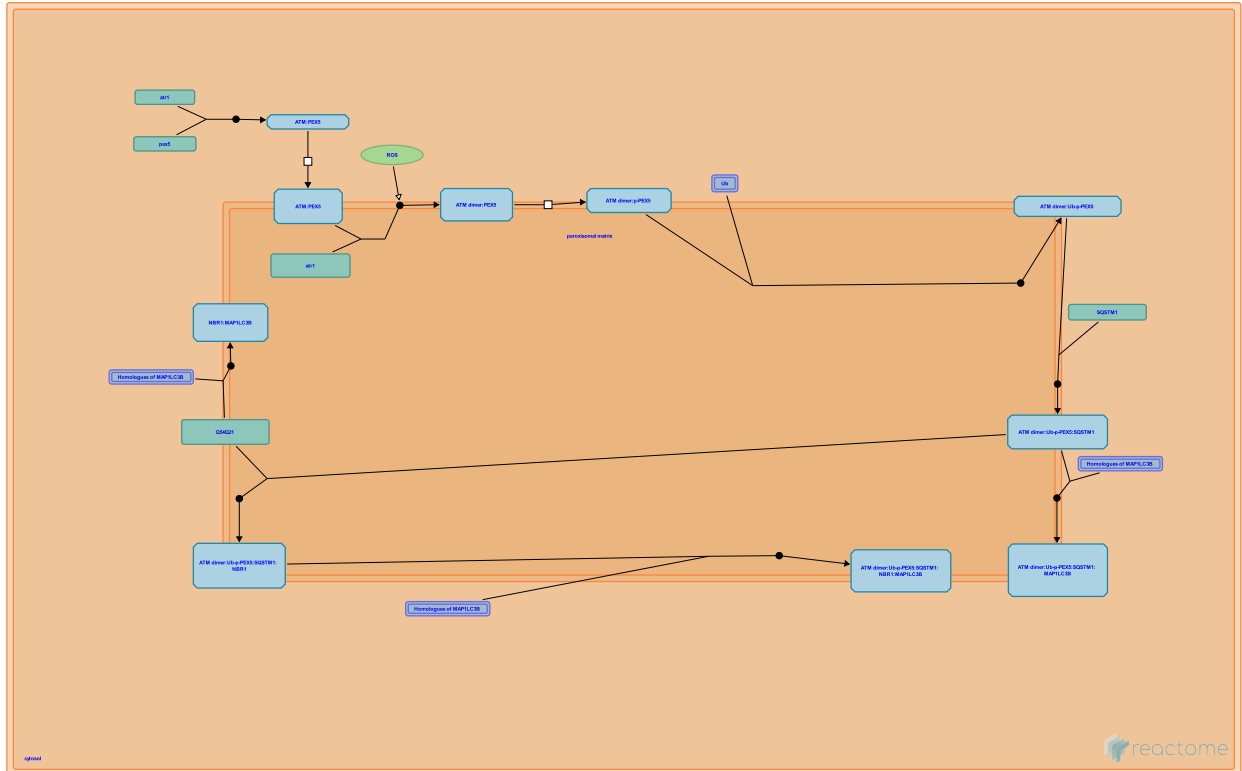

European Bioinformatics Institute, New York University Langone Medical Center, Ontario Institute for Cancer Research, Oregon Health and Science University.

The contents of this document may be freely copied and distributed in any media, provided the authors, plus the institutions, are credited, as stated under the terms of [Creative Commons Attribution 4.0 International \(CC BY 4.0\) License](https://creativecommons.org/licenses/by/4.0/). For more information see our [license](https://reactome.org/licenses/).

This is just an excerpt of a full-length report for this pathway. To access the complete report, please download it at the [Reactome Textbook](https://reactome.org/textbook/).

05/05/2024

## Introduction

Reactome is open-source, open access, manually curated and peer-reviewed pathway database. Pathway annotations are authored by expert biologists, in collaboration with Reactome editorial staff and cross-referenced to many bioinformatics databases. A system of evidence tracking ensures that all assertions are backed up by the primary literature. Reactome is used by clinicians, geneticists, genomics researchers, and molecular biologists to interpret the results of high-throughput experimental studies, by bioinformaticians seeking to develop novel algorithms for mining knowledge from genomic studies, and by systems biologists building predictive models of normal and disease variant pathways.

The development of Reactome is supported by grants from the US National Institutes of Health (P41 HG003751), University of Toronto (CFREF Medicine by Design), European Union (EU STRP, EMI-CD), and the European Molecular Biology Laboratory (EBI Industry program).

## Literature references

- Fabregat, A., Sidiropoulos, K., Viteri, G., Forner, O., Marin-Garcia, P., Arnau, V. et al. (2017). Reactome pathway analysis: a high-performance in-memory approach. *BMC bioinformatics*, 18, 142. [↗](#)
- Sidiropoulos, K., Viteri, G., Sevilla, C., Jupe, S., Webber, M., Orlic-Milacic, M. et al. (2017). Reactome enhanced pathway visualization. *Bioinformatics*, 33, 3461-3467. [↗](#)
- Fabregat, A., Jupe, S., Matthews, L., Sidiropoulos, K., Gillespie, M., Garapati, P. et al. (2018). The Reactome Pathway Knowledgebase. *Nucleic Acids Res*, 46, D649-D655. [↗](#)
- Fabregat, A., Korninger, F., Viteri, G., Sidiropoulos, K., Marin-Garcia, P., Ping, P. et al. (2018). Reactome graph database: Efficient access to complex pathway data. *PLoS computational biology*, 14, e1005968. [↗](#)

Reactome database release: 88

This document contains 1 pathway and 10 reactions ([see Table of Contents](#))

## Pexophagy ↗

**Stable identifier:** R-DDI-9664873

**Compartments:** peroxisomal membrane, cytosol

**Inferred from:** Pexophagy (Homo sapiens)

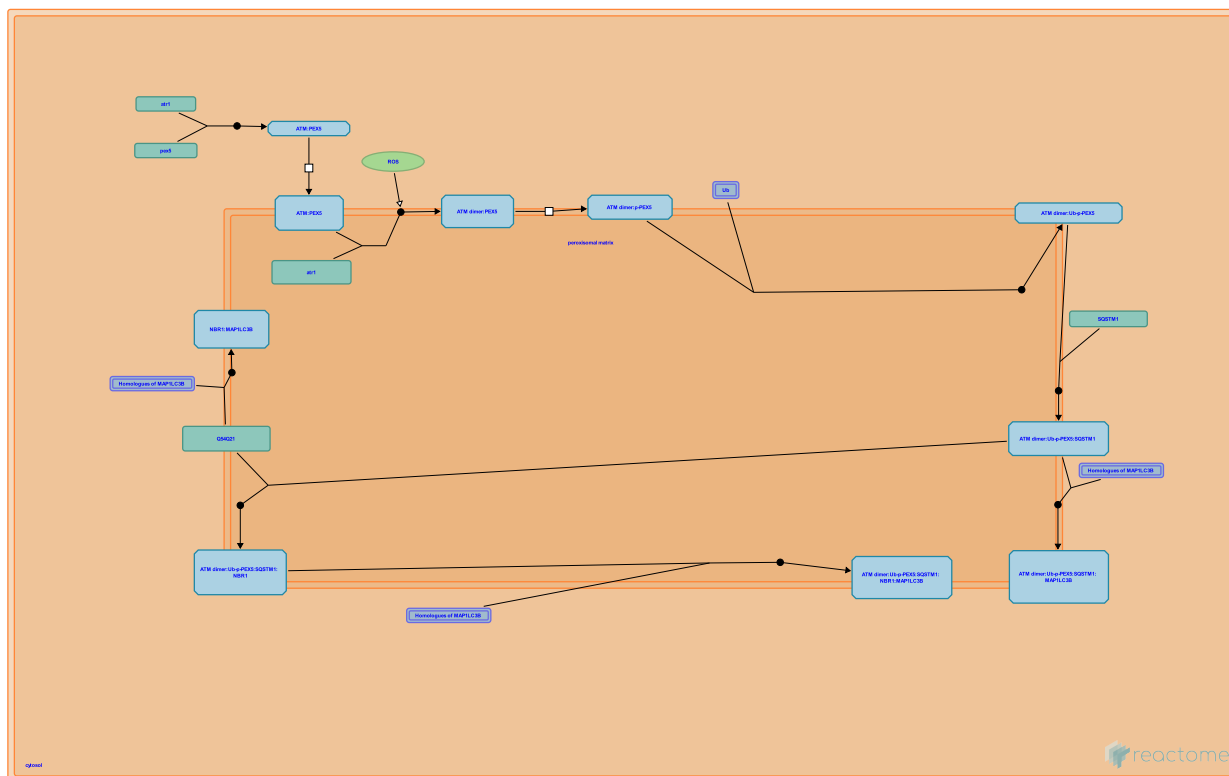

This event has been computationally inferred from an event that has been demonstrated in another species.

The inference is based on the homology mapping from PANTHER. Briefly, reactions for which all involved PhysicalEntities (in input, output and catalyst) have a mapped orthologue/paralogue (for complexes at least 75% of components must have a mapping) are inferred to the other species. High level events are also inferred for these events to allow for easier navigation.

[More details and caveats of the event inference in Reactome.](http://www.pantherdb.org/about.jsp) For details on PANTHER see also: <http://www.pantherdb.org/about.jsp>

## ATM binds PEX5 ↗

**Location:** [Pexophagy](#)

**Stable identifier:** R-DDI-9664850

**Type:** binding

**Compartments:** cytosol

**Inferred from:** [ATM binds PEX5 \(Homo sapiens\)](#)

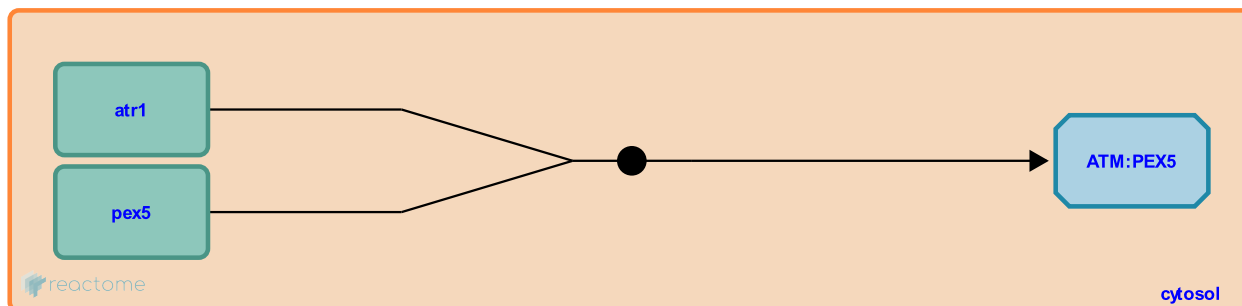

This event has been computationally inferred from an event that has been demonstrated in another species.

The inference is based on the homology mapping from PANTHER. Briefly, reactions for which all involved PhysicalEntities (in input, output and catalyst) have a mapped orthologue/paralogue (for complexes at least 75% of components must have a mapping) are inferred to the other species. High level events are also inferred for these events to allow for easier navigation.

[More details and caveats of the event inference in Reactome.](#) For details on PANTHER see also: <http://www.pantherdb.org/about.jsp>

**Followed by:** [ATM:PEX5 translocates from cytosol to peroxisomal membrane](#)

## ATM:PEX5 translocates from cytosol to peroxisomal membrane ↗

**Location:** [Pexophagy](#)

**Stable identifier:** R-DDI-9664883

**Type:** transition

**Compartments:** peroxisomal membrane, cytosol

**Inferred from:** [ATM:PEX5 translocates from cytosol to peroxisomal membrane \(Homo sapiens\)](#)

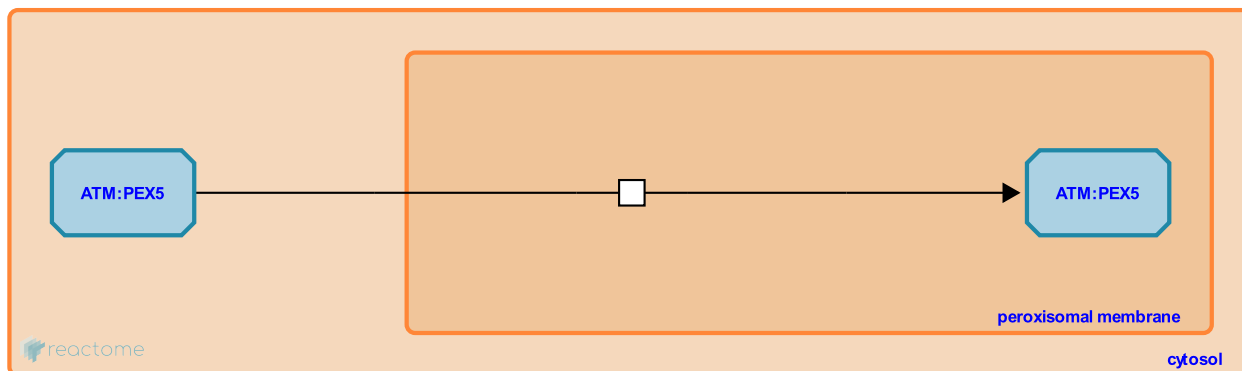

This event has been computationally inferred from an event that has been demonstrated in another species.

The inference is based on the homology mapping from PANTHER. Briefly, reactions for which all involved PhysicalEntities (in input, output and catalyst) have a mapped orthologue/paralogue (for complexes at least 75% of components must have a mapping) are inferred to the other species. High level events are also inferred for these events to allow for easier navigation.

[More details and caveats of the event inference in Reactome.](#) For details on PANTHER see also: <http://www.pantherdb.org/about.jsp>

**Preceded by:** [ATM binds PEX5](#)

**Followed by:** [ATM:PEX5 binds ATM](#)

## ATM:PEX5 binds ATM ↗

**Location:** [Pexophagy](#)

**Stable identifier:** R-DDI-9664879

**Type:** binding

**Compartments:** peroxisomal membrane

**Inferred from:** [ATM:PEX5 binds ATM \(Homo sapiens\)](#)

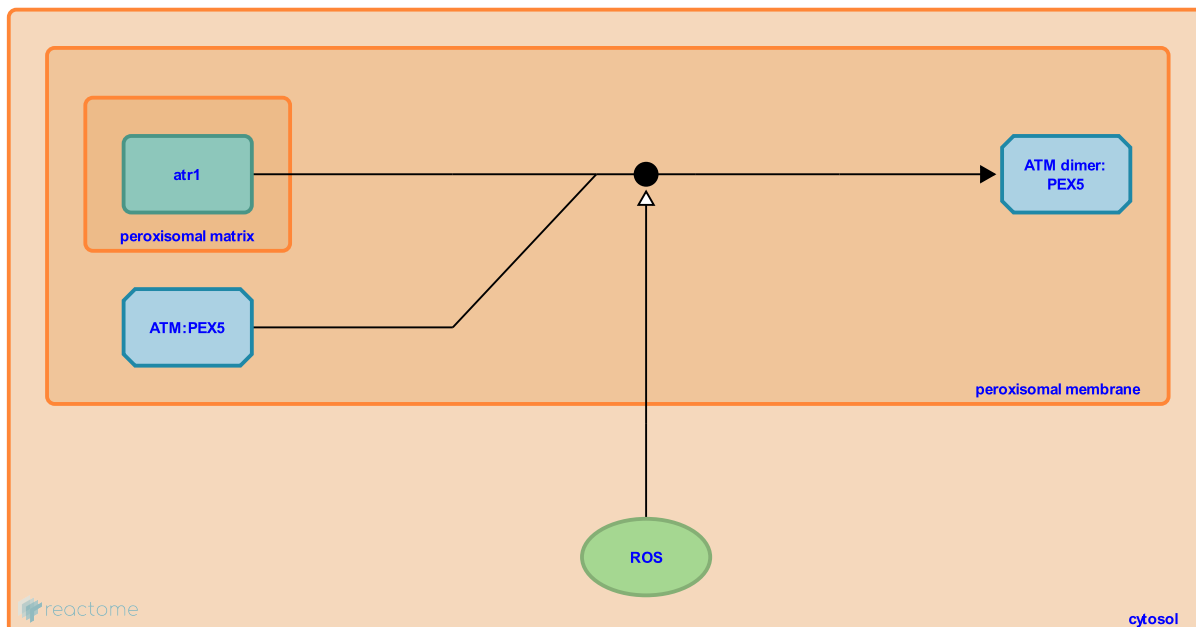

This event has been computationally inferred from an event that has been demonstrated in another species.

The inference is based on the homology mapping from PANTHER. Briefly, reactions for which all involved PhysicalEntities (in input, output and catalyst) have a mapped orthologue/paralogue (for complexes at least 75% of components must have a mapping) are inferred to the other species. High level events are also inferred for these events to allow for easier navigation.

[More details and caveats of the event inference in Reactome.](#) For details on PANTHER see also: <http://www.pantherdb.org/about.jsp>

**Preceded by:** [ATM:PEX5 translocates from cytosol to peroxisomal membrane](#)

**Followed by:** [ATM dimer:PEX5 phosphorylates PEX5](#)

## ATM dimer:PEX5 phosphorylates PEX5 ↗

**Location:** [Pexophagy](#)

**Stable identifier:** R-DDI-9664862

**Type:** transition

**Compartments:** peroxisomal membrane

**Inferred from:** [ATM dimer:PEX5 phosphorylates PEX5 \(Homo sapiens\)](#)

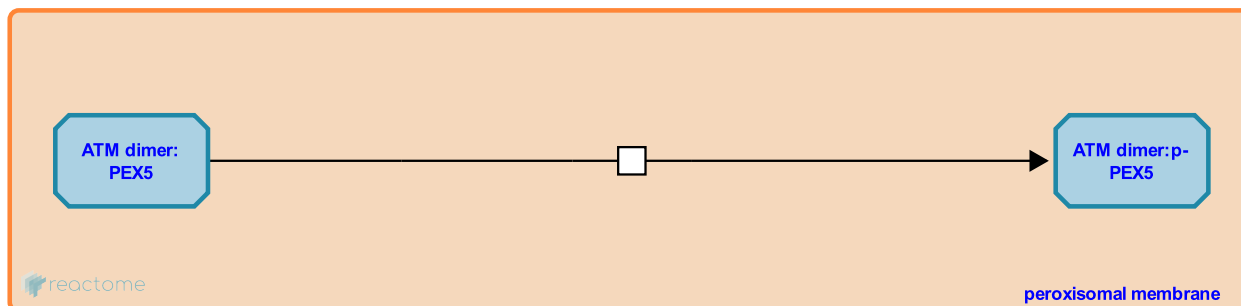

This event has been computationally inferred from an event that has been demonstrated in another species.

The inference is based on the homology mapping from PANTHER. Briefly, reactions for which all involved PhysicalEntities (in input, output and catalyst) have a mapped orthologue/paralogue (for complexes at least 75% of components must have a mapping) are inferred to the other species. High level events are also inferred for these events to allow for easier navigation.

[More details and caveats of the event inference in Reactome.](#) For details on PANTHER see also: <http://www.pantherdb.org/about.jsp>

**Preceded by:** [ATM:PEX5 binds ATM](#)

**Followed by:** [ATM dimer:p-PEX5 ubiquitinates to form ATM dimer:Ub-p-PEX5](#)

## ATM dimer:p-PEX5 ubiquitinates to form ATM dimer:Ub-p-PEX5 ↗

**Location:** [Pexophagy](#)

**Stable identifier:** R-DDI-9664888

**Type:** binding

**Compartments:** peroxisomal membrane

**Inferred from:** [ATM dimer:p-PEX5 ubiquitinates to form ATM dimer:Ub-p-PEX5 \(Homo sapiens\)](#)

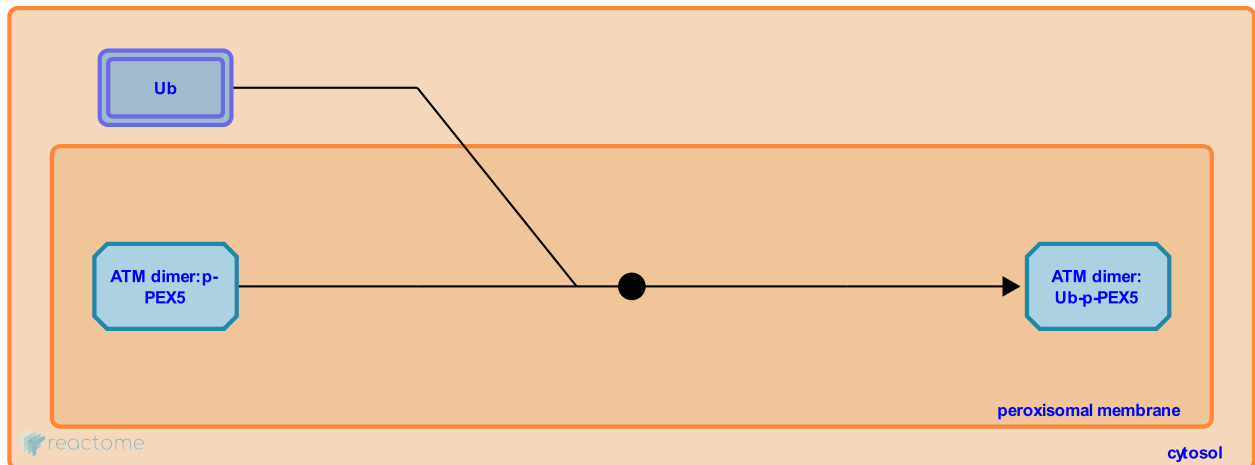

This event has been computationally inferred from an event that has been demonstrated in another species.

The inference is based on the homology mapping from PANTHER. Briefly, reactions for which all involved PhysicalEntities (in input, output and catalyst) have a mapped orthologue/paralogue (for complexes at least 75% of components must have a mapping) are inferred to the other species. High level events are also inferred for these events to allow for easier navigation.

[More details and caveats of the event inference in Reactome.](#) For details on PANTHER see also: <http://www.pantherdb.org/about.jsp>

**Preceded by:** [ATM dimer:PEX5 phosphorylates PEX5](#)

**Followed by:** [SQSTM1 binds ATM dimer:Ub-p-PEX5](#)



## SQSTM1 binds ATM dimer:Ub-p-PEX5 ↗

**Location:** [Pexophagy](#)

**Stable identifier:** R-DDI-9664892

**Type:** binding

**Compartments:** peroxisomal membrane, cytosol

**Inferred from:** [SQSTM1 binds ATM dimer:Ub-p-PEX5 \(Homo sapiens\)](#)

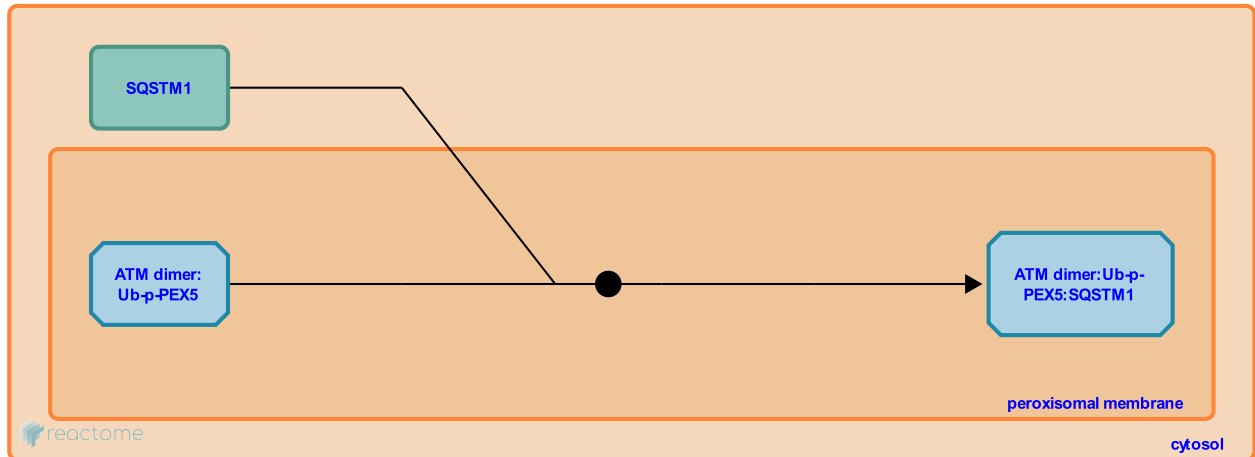

This event has been computationally inferred from an event that has been demonstrated in another species.

The inference is based on the homology mapping from PANTHER. Briefly, reactions for which all involved PhysicalEntities (in input, output and catalyst) have a mapped orthologue/paralogue (for complexes at least 75% of components must have a mapping) are inferred to the other species. High level events are also inferred for these events to allow for easier navigation.

[More details and caveats of the event inference in Reactome.](#) For details on PANTHER see also: <http://www.pantherdb.org/about.jsp>

**Preceded by:** [ATM dimer:p-PEX5 ubiquitinates to form ATM dimer:Ub-p-PEX5](#)

**Followed by:** [MAP1LC3B binds ATM dimer:Ub-p-PEX5:SQSTM1](#), [NBR1 binds ATM:Ub-p-PEX5:SQSTM1](#)

## MAP1LC3B binds ATM dimer:Ub-p-PEX5:SQSTM1 ↗

**Location:** [Pexophagy](#)

**Stable identifier:** R-DDI-9664855

**Type:** binding

**Compartments:** peroxisomal membrane

**Inferred from:** [MAP1LC3B binds ATM dimer:Ub-p-PEX5:SQSTM1 \(Homo sapiens\)](#)

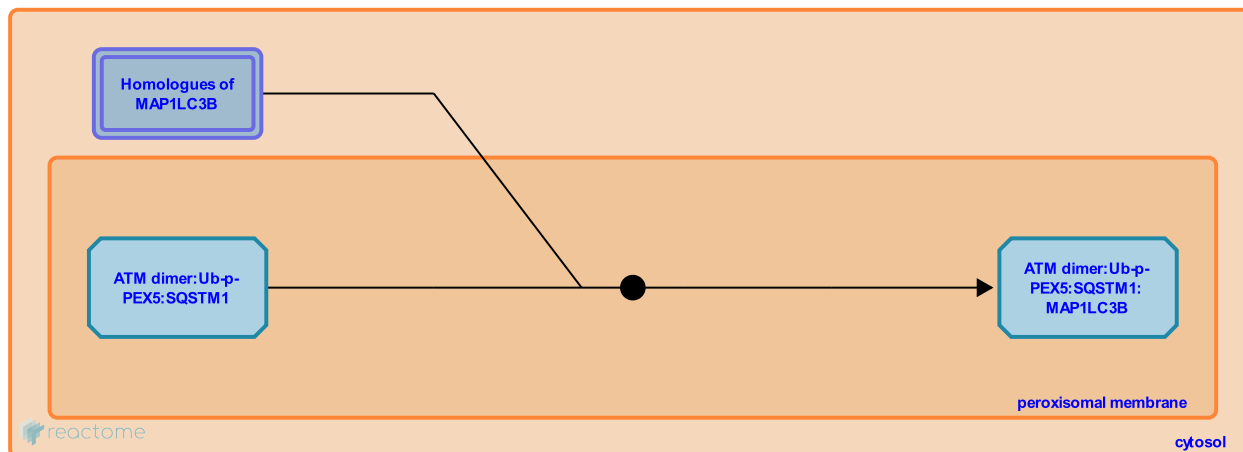

This event has been computationally inferred from an event that has been demonstrated in another species.

The inference is based on the homology mapping from PANTHER. Briefly, reactions for which all involved PhysicalEntities (in input, output and catalyst) have a mapped orthologue/paralogue (for complexes at least 75% of components must have a mapping) are inferred to the other species. High level events are also inferred for these events to allow for easier navigation.

[More details and caveats of the event inference in Reactome.](#) For details on PANTHER see also: <http://www.pantherdb.org/about.jsp>

**Preceded by:** [SQSTM1 binds ATM dimer:Ub-p-PEX5](#)

## NBR1 binds MAP1LC3B ↗

**Location:** [Pexophagy](#)

**Stable identifier:** R-DDI-9664867

**Type:** binding

**Compartments:** peroxisomal membrane

**Inferred from:** [NBR1 binds MAP1LC3B \(Homo sapiens\)](#)

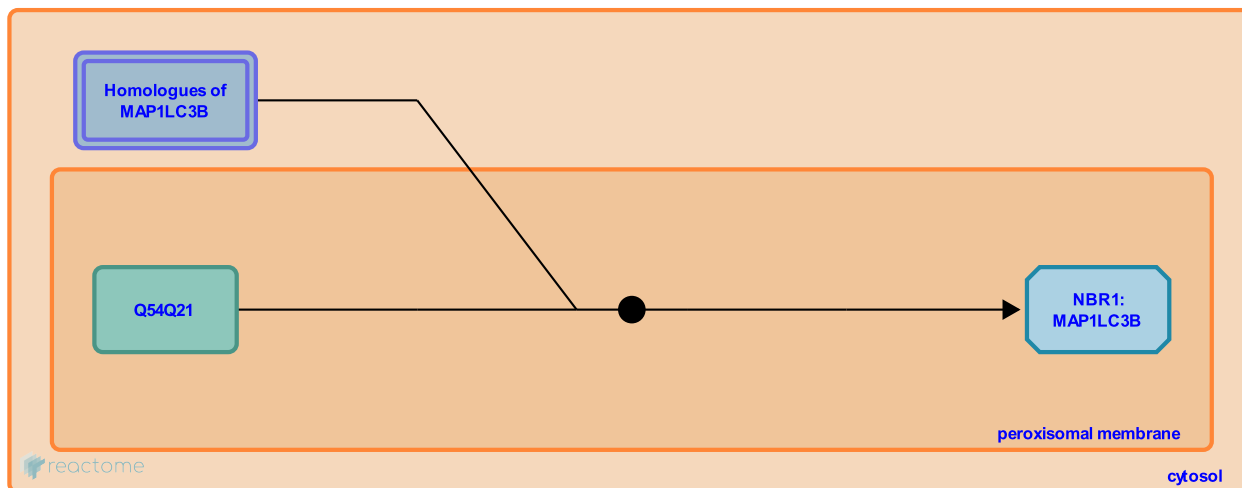

This event has been computationally inferred from an event that has been demonstrated in another species.

The inference is based on the homology mapping from PANTHER. Briefly, reactions for which all involved PhysicalEntities (in input, output and catalyst) have a mapped orthologue/paralogue (for complexes at least 75% of components must have a mapping) are inferred to the other species. High level events are also inferred for these events to allow for easier navigation.

[More details and caveats of the event inference in Reactome.](#) For details on PANTHER see also: <http://www.pantherdb.org/about.jsp>

## NBR1 binds ATM:Ub-p-PEX5:SQSTM1 ↗

**Location:** [Pexophagy](#)

**Stable identifier:** R-DDI-9664881

**Type:** binding

**Compartments:** peroxisomal membrane

**Inferred from:** [NBR1 binds ATM:Ub-p-PEX5:SQSTM1 \(Homo sapiens\)](#)

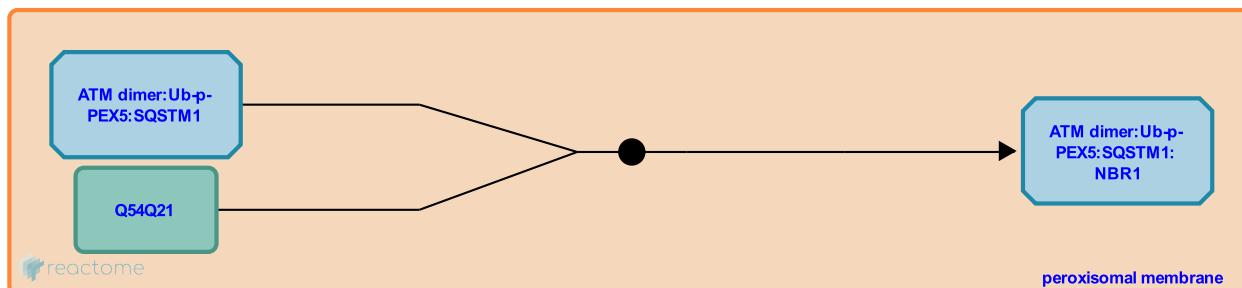

This event has been computationally inferred from an event that has been demonstrated in another species.

The inference is based on the homology mapping from PANTHER. Briefly, reactions for which all involved PhysicalEntities (in input, output and catalyst) have a mapped orthologue/paralogue (for complexes at least 75% of components must have a mapping) are inferred to the other species. High level events are also inferred for these events to allow for easier navigation.

[More details and caveats of the event inference in Reactome.](#) For details on PANTHER see also: <http://www.pantherdb.org/about.jsp>

**Preceded by:** [SQSTM1 binds ATM dimer:Ub-p-PEX5](#)

**Followed by:** [MAP1LC3B binds ATM dimer:Ub-p-PEX5:SQSTM1:NBR1](#)

## MAP1LC3B binds ATM dimer:Ub-p-PEX5:SQSTM1:NBR1 ↗

**Location:** [Pexophagy](#)

**Stable identifier:** R-DDI-9664880

**Type:** binding

**Compartments:** peroxisomal membrane

**Inferred from:** [MAP1LC3B binds ATM dimer:Ub-p-PEX5:SQSTM1:NBR1 \(Homo sapiens\)](#)

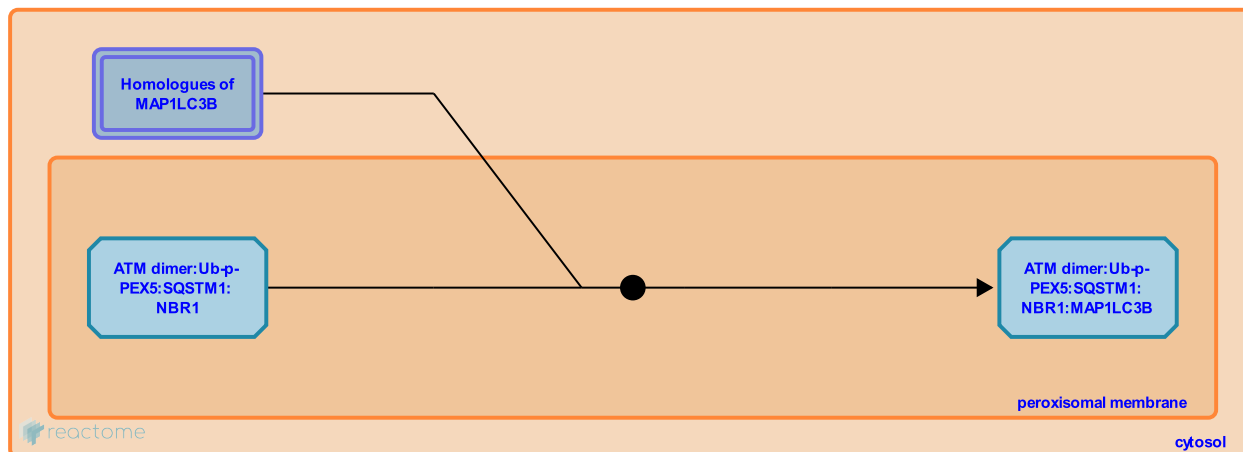

This event has been computationally inferred from an event that has been demonstrated in another species.

The inference is based on the homology mapping from PANTHER. Briefly, reactions for which all involved PhysicalEntities (in input, output and catalyst) have a mapped orthologue/paralogue (for complexes at least 75% of components must have a mapping) are inferred to the other species. High level events are also inferred for these events to allow for easier navigation.

[More details and caveats of the event inference in Reactome.](#) For details on PANTHER see also: <http://www.pantherdb.org/about.jsp>

**Preceded by:** [NBR1 binds ATM:Ub-p-PEX5:SQSTM1](#)

# Table of Contents

Introduction	1
 Pexophagy	2
↳ ATM binds PEX5	3
↳ ATM:PEX5 translocates from cytosol to peroxisomal membrane	4
↳ ATM:PEX5 binds ATM	5
↳ ATM dimer:PEX5 phosphorylates PEX5	6
↳ ATM dimer:p-PEX5 ubiquitinates to form ATM dimer:Ub-p-PEX5	7
↳ SQSTM1 binds ATM dimer:Ub-p-PEX5	8
↳ MAP1LC3B binds ATM dimer:Ub-p-PEX5:SQSTM1	9
↳ NBR1 binds MAP1LC3B	10
↳ NBR1 binds ATM:Ub-p-PEX5:SQSTM1	11
↳ MAP1LC3B binds ATM dimer:Ub-p-PEX5:SQSTM1:NBR1	12
Table of Contents	13