

EGFR downregulation

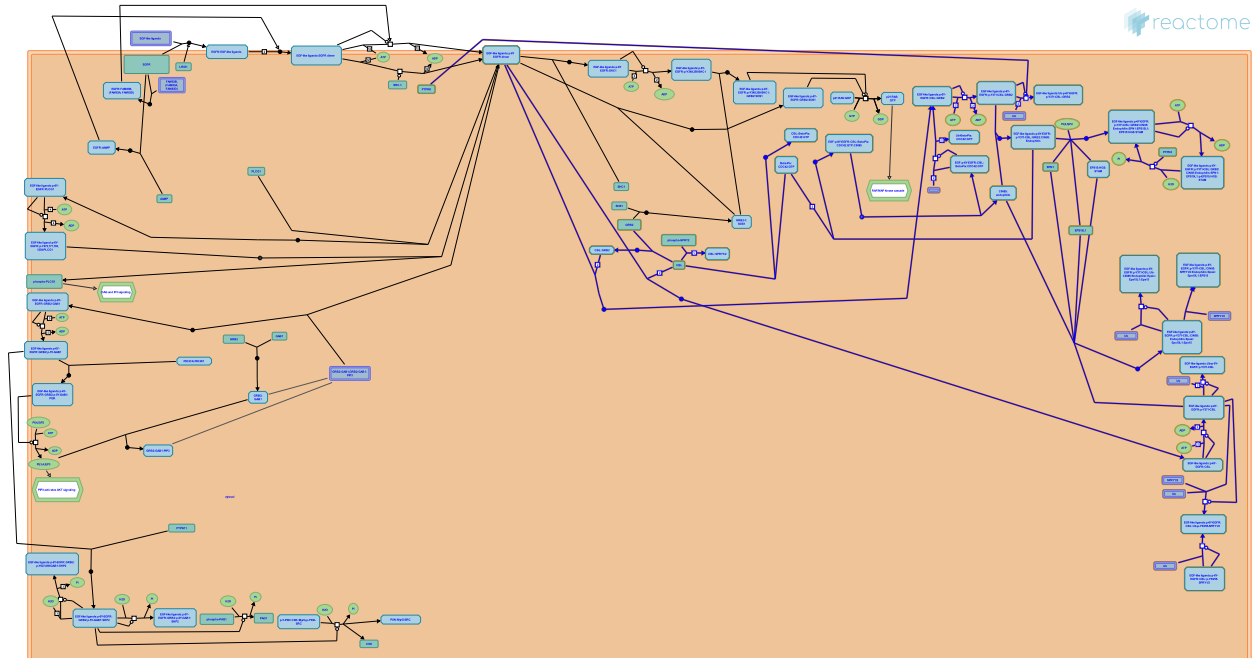

European Bioinformatics Institute, New York University Langone Medical Center, Ontario Institute for Cancer Research, Oregon Health and Science University.

The contents of this document may be freely copied and distributed in any media, provided the authors, plus the institutions, are credited, as stated under the terms of [Creative Commons Attribution 4.0 International \(CC BY 4.0\) License](https://creativecommons.org/licenses/by/4.0/). For more information see our [license](https://reactome.org/licenses).

This is just an excerpt of a full-length report for this pathway. To access the complete report, please download it at the [Reactome Textbook](https://reactome.org/textbook).

03/05/2024

Introduction

Reactome is open-source, open access, manually curated and peer-reviewed pathway database. Pathway annotations are authored by expert biologists, in collaboration with Reactome editorial staff and cross-referenced to many bioinformatics databases. A system of evidence tracking ensures that all assertions are backed up by the primary literature. Reactome is used by clinicians, geneticists, genomics researchers, and molecular biologists to interpret the results of high-throughput experimental studies, by bioinformaticians seeking to develop novel algorithms for mining knowledge from genomic studies, and by systems biologists building predictive models of normal and disease variant pathways.

The development of Reactome is supported by grants from the US National Institutes of Health (P41 HG003751), University of Toronto (CFREF Medicine by Design), European Union (EU STRP, EMI-CD), and the European Molecular Biology Laboratory (EBI Industry program).

Literature references

- Fabregat, A., Sidiropoulos, K., Viteri, G., Forner, O., Marin-Garcia, P., Arnau, V. et al. (2017). Reactome pathway analysis: a high-performance in-memory approach. *BMC bioinformatics*, 18, 142. [↗](#)
- Sidiropoulos, K., Viteri, G., Sevilla, C., Jupe, S., Webber, M., Orlic-Milacic, M. et al. (2017). Reactome enhanced pathway visualization. *Bioinformatics*, 33, 3461-3467. [↗](#)
- Fabregat, A., Jupe, S., Matthews, L., Sidiropoulos, K., Gillespie, M., Garapati, P. et al. (2018). The Reactome Pathway Knowledgebase. *Nucleic Acids Res*, 46, D649-D655. [↗](#)
- Fabregat, A., Korninger, F., Viteri, G., Sidiropoulos, K., Marin-Garcia, P., Ping, P. et al. (2018). Reactome graph database: Efficient access to complex pathway data. *PLoS computational biology*, 14, e1005968. [↗](#)

Reactome database release: 88

This document contains 1 pathway and 21 reactions ([see Table of Contents](#))

EGFR downregulation ↗

Stable identifier: R-BTA-182971

Inferred from: EGFR downregulation (Homo sapiens)

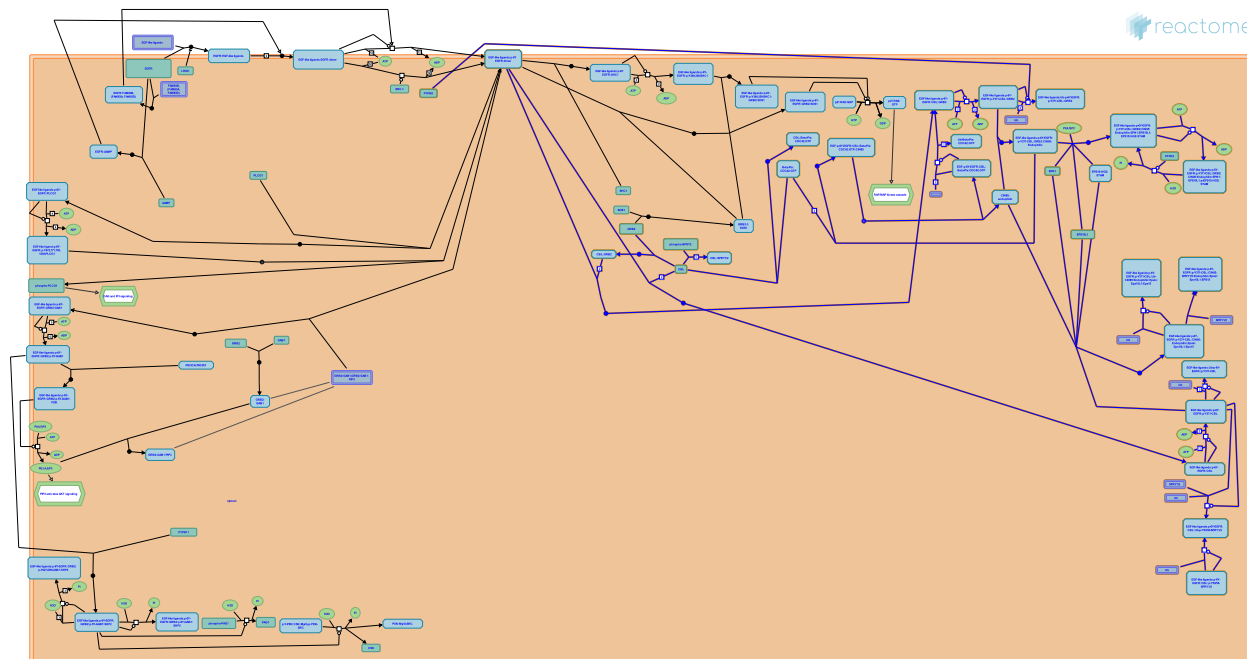

This event has been computationally inferred from an event that has been demonstrated in another species.

The inference is based on the homology mapping from PANTHER. Briefly, reactions for which all involved PhysicalEntities (in input, output and catalyst) have a mapped orthologue/paralogue (for complexes at least 75% of components must have a mapping) are inferred to the other species. High level events are also inferred for these events to allow for easier navigation.

[More details and caveats of the event inference in Reactome.](#) For details on PANTHER see also: <http://www.pantherdb.org/about.jsp>

Binding of CBL to EGFR ↗

Location: [EGFR downregulation](#)

Stable identifier: R-BTA-183055

Type: binding

Compartments: plasma membrane, extracellular region

Inferred from: [Binding of CBL to EGFR \(Homo sapiens\)](#)

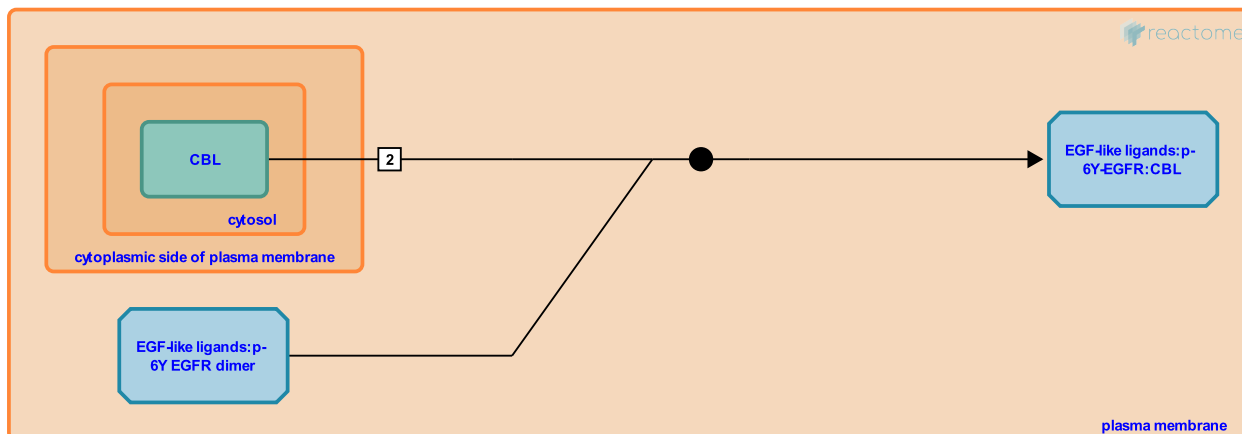

This event has been computationally inferred from an event that has been demonstrated in another species.

The inference is based on the homology mapping from PANTHER. Briefly, reactions for which all involved PhysicalEntities (in input, output and catalyst) have a mapped orthologue/paralogue (for complexes at least 75% of components must have a mapping) are inferred to the other species. High level events are also inferred for these events to allow for easier navigation.

[More details and caveats of the event inference in Reactome.](#) For details on PANTHER see also: <http://www.pantherdb.org/about.jsp>

Followed by: [Phosphorylation of CBL \(EGFR:CBL\)](#)

Phosphorylation of CBL (EGFR:CBL) ↗

Location: [EGFR downregulation](#)

Stable identifier: R-BTA-182969

Type: transition

Compartments: plasma membrane, cytosol

Inferred from: [Phosphorylation of CBL \(EGFR:CBL\) \(Homo sapiens\)](#)

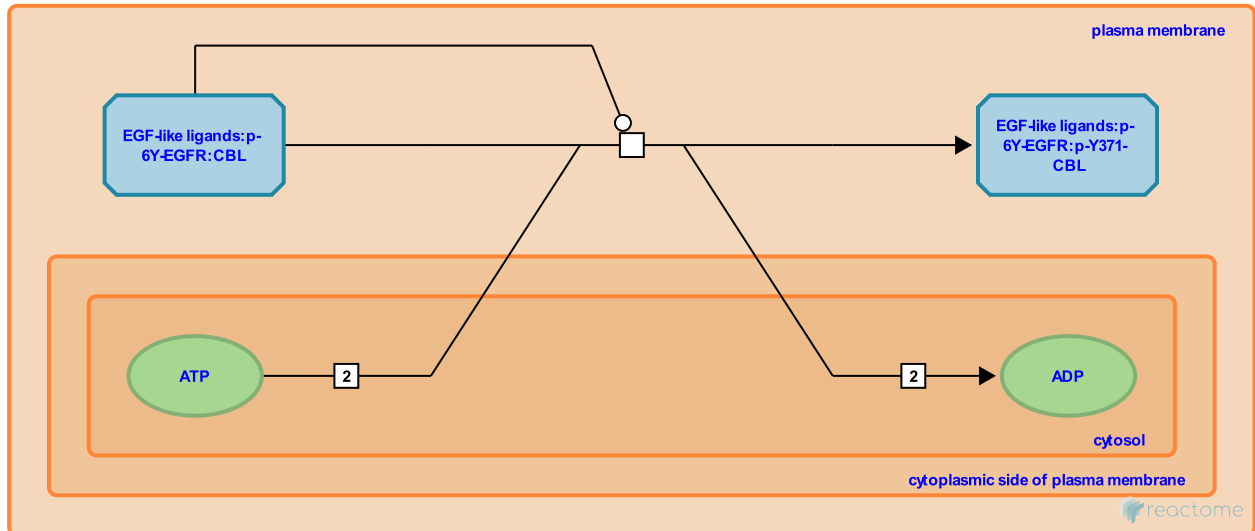

This event has been computationally inferred from an event that has been demonstrated in another species.

The inference is based on the homology mapping from PANTHER. Briefly, reactions for which all involved PhysicalEntities (in input, output and catalyst) have a mapped orthologue/paralogue (for complexes at least 75% of components must have a mapping) are inferred to the other species. High level events are also inferred for these events to allow for easier navigation.

[More details and caveats of the event inference in Reactome.](#) For details on PANTHER see also: <http://www.pantherdb.org/about.jsp>

Preceded by: [Binding of CBL to EGFR](#)

Followed by: [Ubiquitination of stimulated EGFR \(CBL\), CBL binds and ubiquitinates phosphorylated Sprouty](#)

CBL binds and ubiquitinates phosphorylated Sprouty ↗

Location: [EGFR downregulation](#)

Stable identifier: R-BTA-183089

Type: transition

Compartments: plasma membrane, cytosol

Inferred from: [CBL binds and ubiquitinates phosphorylated Sprouty \(Homo sapiens\)](#)

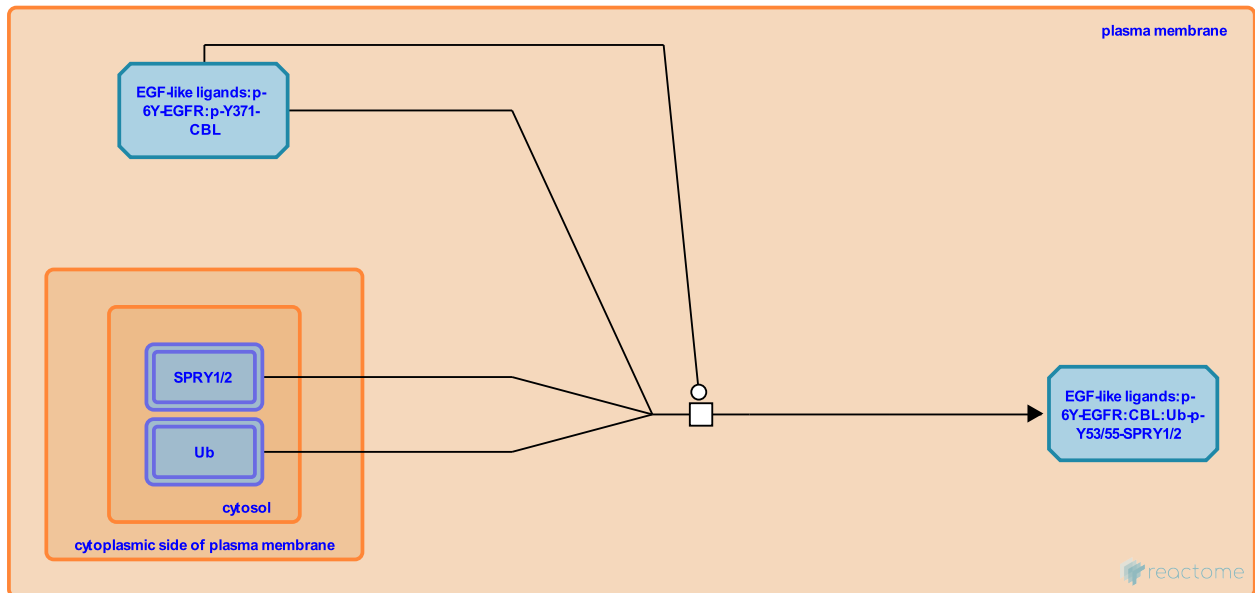

This event has been computationally inferred from an event that has been demonstrated in another species.

The inference is based on the homology mapping from PANTHER. Briefly, reactions for which all involved PhysicalEntities (in input, output and catalyst) have a mapped orthologue/paralogue (for complexes at least 75% of components must have a mapping) are inferred to the other species. High level events are also inferred for these events to allow for easier navigation.

[More details and caveats of the event inference in Reactome.](#) For details on PANTHER see also: <http://www.pantherdb.org/about.jsp>

Preceded by: [Phosphorylation of CBL \(EGFR:CBL\)](#)

Ubiquitination of stimulated EGFR (CBL) ↗

Location: [EGFR downregulation](#)

Stable identifier: R-BTA-182993

Type: transition

Compartments: plasma membrane, cytosol

Inferred from: [Ubiquitination of stimulated EGFR \(CBL\) \(Homo sapiens\)](#)

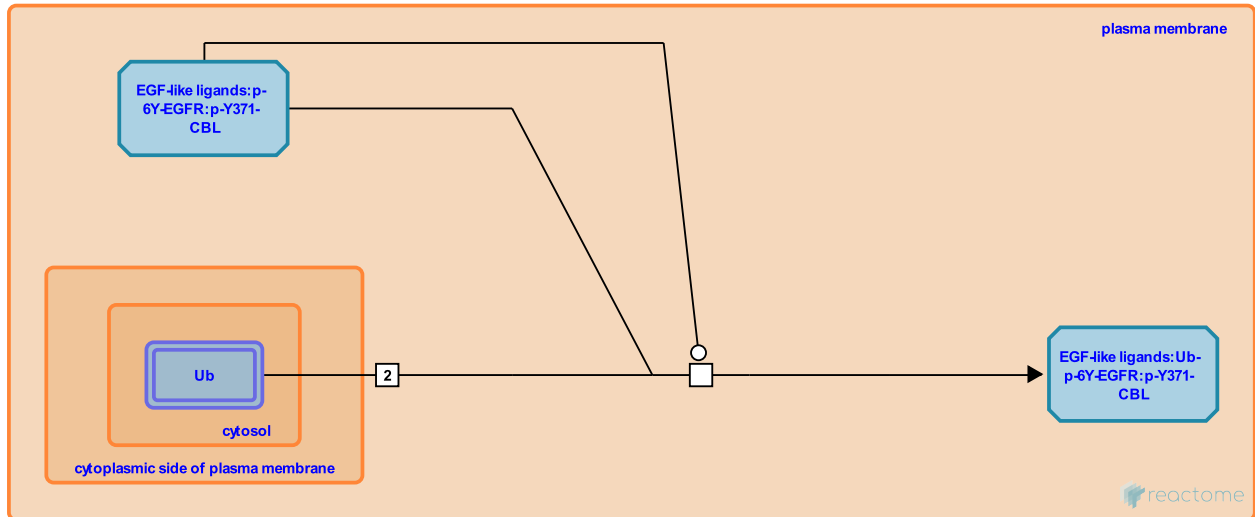

This event has been computationally inferred from an event that has been demonstrated in another species.

The inference is based on the homology mapping from PANTHER. Briefly, reactions for which all involved PhysicalEntities (in input, output and catalyst) have a mapped orthologue/paralogue (for complexes at least 75% of components must have a mapping) are inferred to the other species. High level events are also inferred for these events to allow for easier navigation.

[More details and caveats of the event inference in Reactome.](#) For details on PANTHER see also: <http://www.pantherdb.org/about.jsp>

Preceded by: [Phosphorylation of CBL \(EGFR:CBL\)](#)

CBL binds to GRB2 ↗

Location: [EGFR downregulation](#)

Stable identifier: R-BTA-183052

Type: binding

Compartments: cytosol

Inferred from: [CBL binds to GRB2 \(Homo sapiens\)](#)

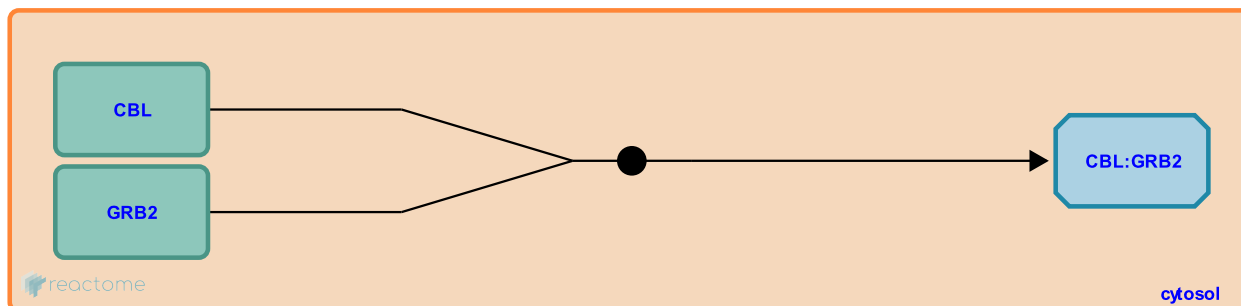

This event has been computationally inferred from an event that has been demonstrated in another species.

The inference is based on the homology mapping from PANTHER. Briefly, reactions for which all involved PhysicalEntities (in input, output and catalyst) have a mapped orthologue/paralogue (for complexes at least 75% of components must have a mapping) are inferred to the other species. High level events are also inferred for these events to allow for easier navigation.

[More details and caveats of the event inference in Reactome.](#) For details on PANTHER see also: <http://www.pantherdb.org/about.jsp>

Followed by: [Localization of CBL:GRB2 to the membrane](#)

Localization of CBL:GRB2 to the membrane ↗

Location: [EGFR downregulation](#)

Stable identifier: R-BTA-183067

Type: binding

Compartments: plasma membrane, extracellular region, cytosol

Inferred from: [Localization of CBL:GRB2 to the membrane \(Homo sapiens\)](#)

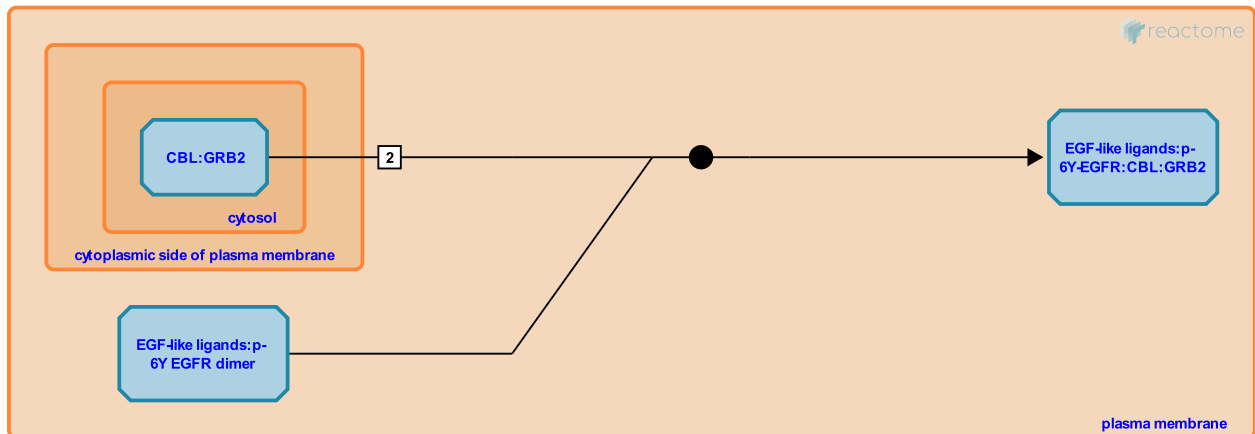

This event has been computationally inferred from an event that has been demonstrated in another species.

The inference is based on the homology mapping from PANTHER. Briefly, reactions for which all involved PhysicalEntities (in input, output and catalyst) have a mapped orthologue/paralogue (for complexes at least 75% of components must have a mapping) are inferred to the other species. High level events are also inferred for these events to allow for easier navigation.

[More details and caveats of the event inference in Reactome.](#) For details on PANTHER see also: <http://www.pantherdb.org/about.jsp>

Preceded by: [CBL binds to GRB2](#)

Followed by: [Phosphorylation of CBL \(EGFR:GRB2:CBL\)](#)

Phosphorylation of CBL (EGFR:GRB2:CBL) ↗

Location: [EGFR downregulation](#)

Stable identifier: R-BTA-183058

Type: transition

Compartments: plasma membrane, cytosol

Inferred from: [Phosphorylation of CBL \(EGFR:GRB2:CBL\) \(Homo sapiens\)](#)

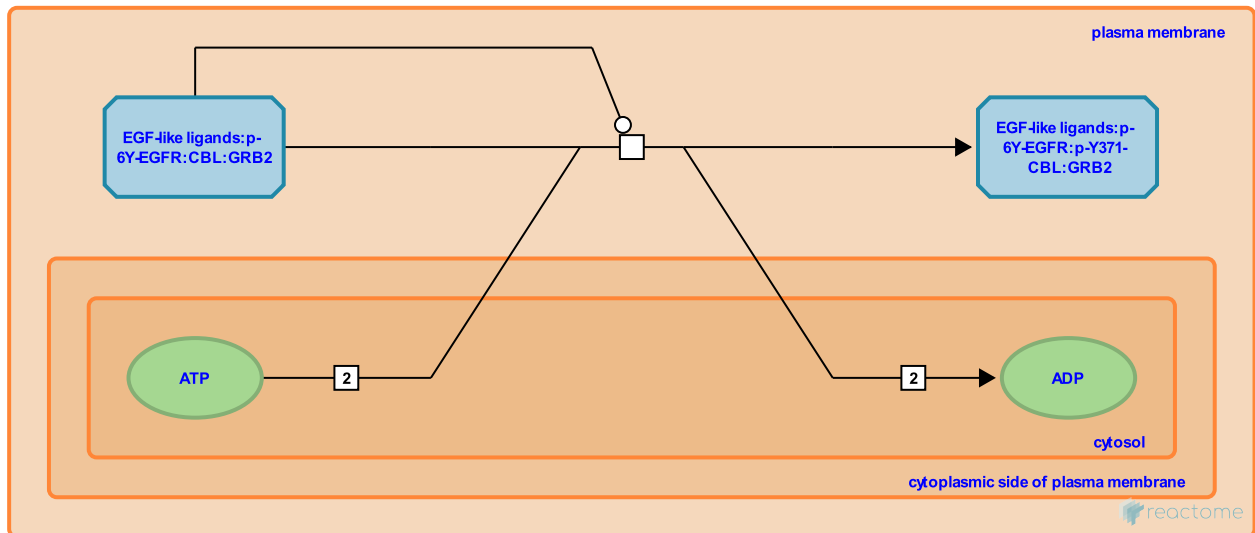

This event has been computationally inferred from an event that has been demonstrated in another species.

The inference is based on the homology mapping from PANTHER. Briefly, reactions for which all involved PhysicalEntities (in input, output and catalyst) have a mapped orthologue/paralogue (for complexes at least 75% of components must have a mapping) are inferred to the other species. High level events are also inferred for these events to allow for easier navigation.

[More details and caveats of the event inference in Reactome.](#) For details on PANTHER see also: <http://www.pantherdb.org/about.jsp>

Preceded by: [Localization of CBL:GRB2 to the membrane](#)

Followed by: [Ubiquitination of stimulated EGFR \(CBL:GRB2\)](#)

Ubiquitination of stimulated EGFR (CBL:GRB2) ↗

Location: EGFR downregulation

Stable identifier: R-BTA-183036

Type: transition

Compartments: plasma membrane, cytosol

Inferred from: Ubiquitination of stimulated EGFR (CBL:GRB2) (Homo sapiens)

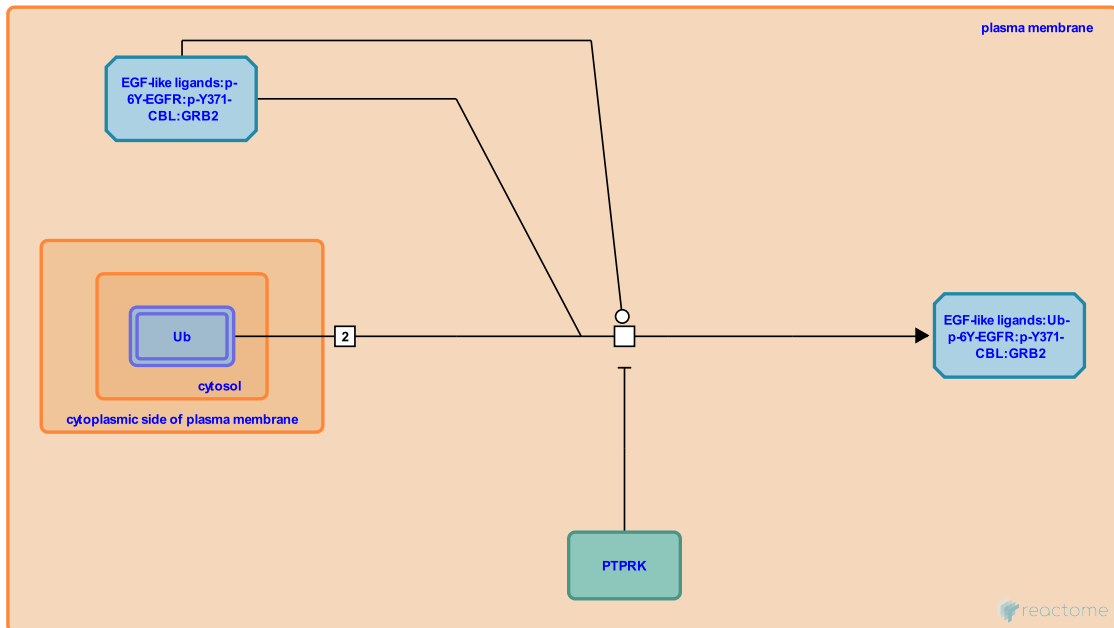

This event has been computationally inferred from an event that has been demonstrated in another species.

The inference is based on the homology mapping from PANTHER. Briefly, reactions for which all involved PhysicalEntities (in input, output and catalyst) have a mapped orthologue/paralogue (for complexes at least 75% of components must have a mapping) are inferred to the other species. High level events are also inferred for these events to allow for easier navigation.

[More details and caveats of the event inference in Reactome.](http://www.pantherdb.org/about.jsp) For details on PANTHER see also: <http://www.pantherdb.org/about.jsp>

Preceded by: Phosphorylation of CBL (EGFR:GRB2:CBL)

Sprouty lures CBL away from EGFR ↗

Location: [EGFR downregulation](#)

Stable identifier: R-BTA-182988

Type: omitted

Compartments: plasma membrane

Inferred from: [Sprouty lures CBL away from EGFR \(Homo sapiens\)](#)

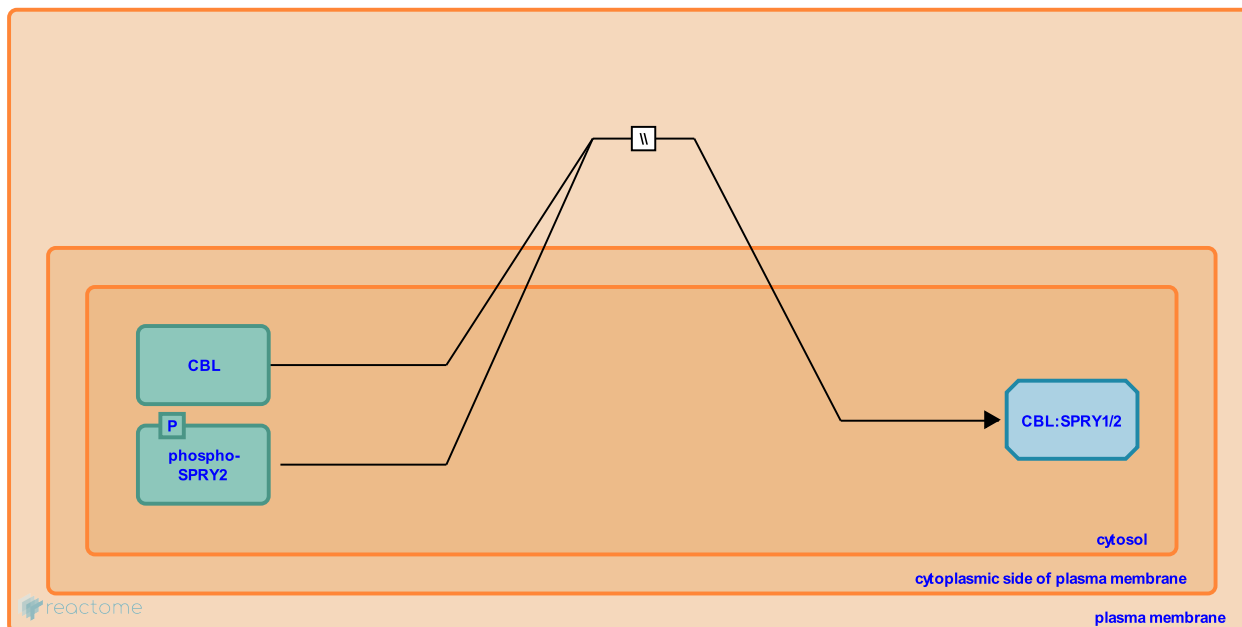

This event has been computationally inferred from an event that has been demonstrated in another species.

The inference is based on the homology mapping from PANTHER. Briefly, reactions for which all involved PhysicalEntities (in input, output and catalyst) have a mapped orthologue/paralogue (for complexes at least 75% of components must have a mapping) are inferred to the other species. High level events are also inferred for these events to allow for easier navigation.

[More details and caveats of the event inference in Reactome.](#) For details on PANTHER see also: <http://www.pantherdb.org/about.jsp>

CDC42:GTP binds CBL:Beta-Pix ↗

Location: [EGFR downregulation](#)

Stable identifier: R-BTA-183094

Type: binding

Compartments: cytosol

Inferred from: [CDC42:GTP binds CBL:Beta-Pix \(Homo sapiens\)](#)

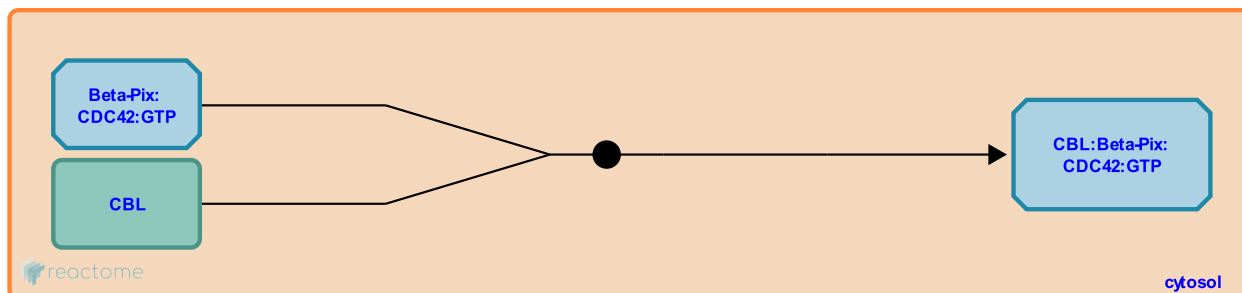

This event has been computationally inferred from an event that has been demonstrated in another species.

The inference is based on the homology mapping from PANTHER. Briefly, reactions for which all involved PhysicalEntities (in input, output and catalyst) have a mapped orthologue/paralogue (for complexes at least 75% of components must have a mapping) are inferred to the other species. High level events are also inferred for these events to allow for easier navigation.

[More details and caveats of the event inference in Reactome.](#) For details on PANTHER see also: <http://www.pantherdb.org/about.jsp>

Beta-Pix: CDC42:GTP binds CBL in EGF:p-6Y-EGFR:CBL:CIN85 ↗

Location: [EGFR downregulation](#)

Stable identifier: R-BTA-183002

Type: binding

Compartments: plasma membrane, cytosol

Inferred from: [Beta-Pix: CDC42:GTP binds CBL in EGF:p-6Y-EGFR:CBL:CIN85 \(Homo sapiens\)](#)

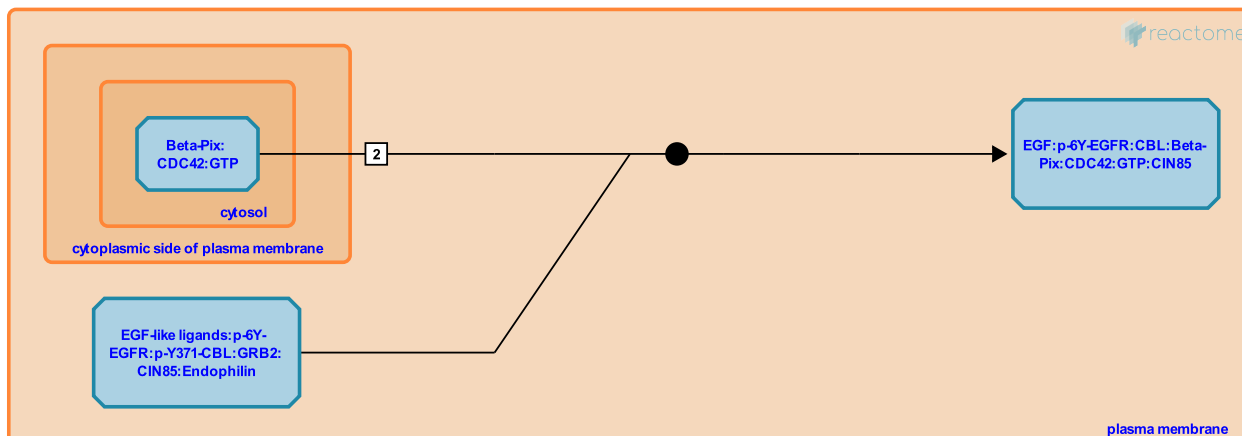

This event has been computationally inferred from an event that has been demonstrated in another species.

The inference is based on the homology mapping from PANTHER. Briefly, reactions for which all involved PhysicalEntities (in input, output and catalyst) have a mapped orthologue/paralogue (for complexes at least 75% of components must have a mapping) are inferred to the other species. High level events are also inferred for these events to allow for easier navigation.

[More details and caveats of the event inference in Reactome.](#) For details on PANTHER see also: <http://www.pantherdb.org/about.jsp>

Followed by: [CIN85 dissociates from EGF:p-6Y-EGFR:CBL:Beta-Pix: CDC42:GTP: CIN85](#)

CIN85 dissociates from EGF:p-6Y-EGFR:CBL:Beta-Pix: CDC42:GTP:CIN85 ↗

Location: [EGFR downregulation](#)

Stable identifier: R-BTA-8951490

Type: dissociation

Compartments: plasma membrane, cytosol

Inferred from: [CIN85 dissociates from EGF:p-6Y-EGFR:CBL:Beta-Pix: CDC42:GTP:CIN85 \(Homo sapiens\)](#)

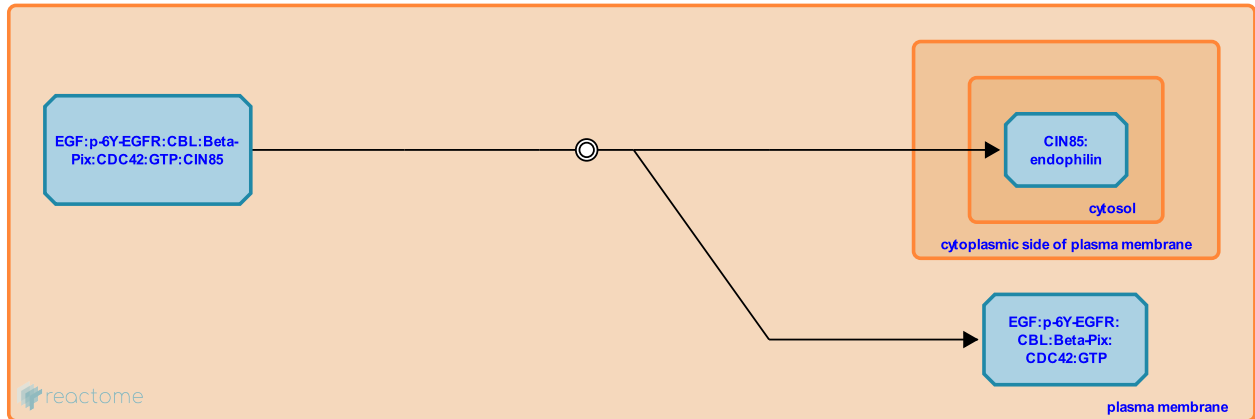

This event has been computationally inferred from an event that has been demonstrated in another species.

The inference is based on the homology mapping from PANTHER. Briefly, reactions for which all involved PhysicalEntities (in input, output and catalyst) have a mapped orthologue/paralogue (for complexes at least 75% of components must have a mapping) are inferred to the other species. High level events are also inferred for these events to allow for easier navigation.

[More details and caveats of the event inference in Reactome.](#) For details on PANTHER see also: <http://www.pantherdb.org/about.jsp>

Preceded by: [Beta-Pix: CDC42:GTP binds CBL in EGF:p-6Y-EGFR:CBL:CIN85](#)

Followed by: [CBL escapes CDC42-mediated inhibition by down-regulating the adaptor molecule Beta-Pix](#)

CBL escapes CDC42-mediated inhibition by down-regulating the adaptor molecule Beta-Pix ↗

Location: [EGFR downregulation](#)

Stable identifier: R-BTA-183084

Type: transition

Compartments: plasma membrane, cytosol

Inferred from: [CBL escapes CDC42-mediated inhibition by down-regulating the adaptor molecule Beta-Pix \(Homo sapiens\)](#)

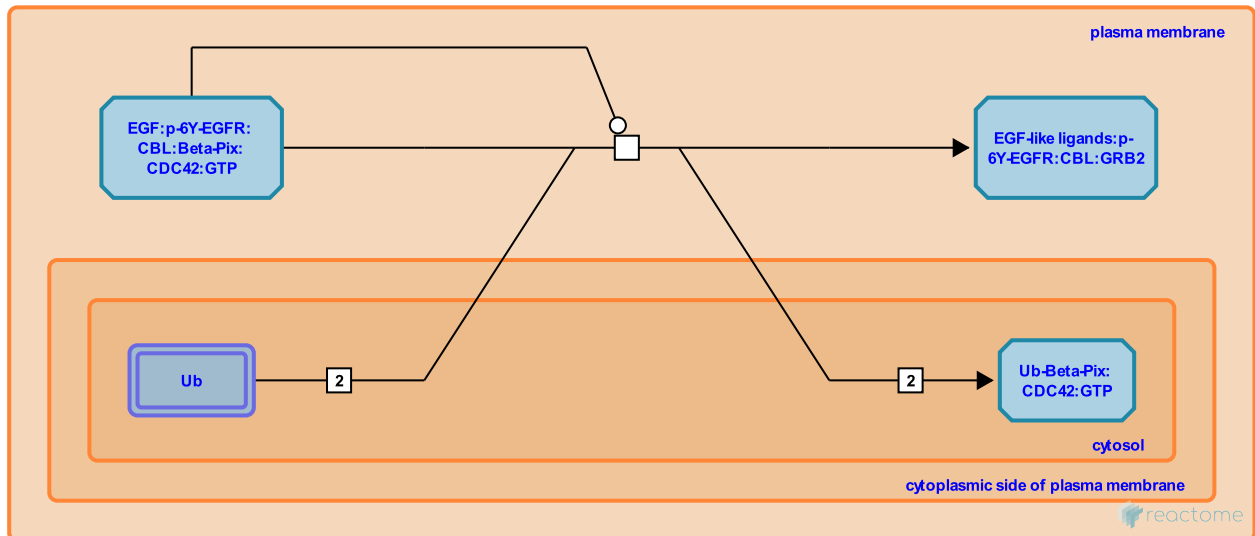

This event has been computationally inferred from an event that has been demonstrated in another species.

The inference is based on the homology mapping from PANTHER. Briefly, reactions for which all involved PhysicalEntities (in input, output and catalyst) have a mapped orthologue/paralogue (for complexes at least 75% of components must have a mapping) are inferred to the other species. High level events are also inferred for these events to allow for easier navigation.

[More details and caveats of the event inference in Reactome.](#) For details on PANTHER see also: <http://www.pantherdb.org/about.jsp>

Preceded by: [CIN85 dissociates from EGF:p-6Y-EGFR:CBL:Beta-Pix: CDC42:GTP:CIN85](#)

Assembly of EGFR complex in clathrin-coated vesicles ↗

Location: [EGFR downregulation](#)

Stable identifier: R-BTA-182994

Type: binding

Compartments: plasma membrane, cytosol

Inferred from: [Assembly of EGFR complex in clathrin-coated vesicles \(Homo sapiens\)](#)

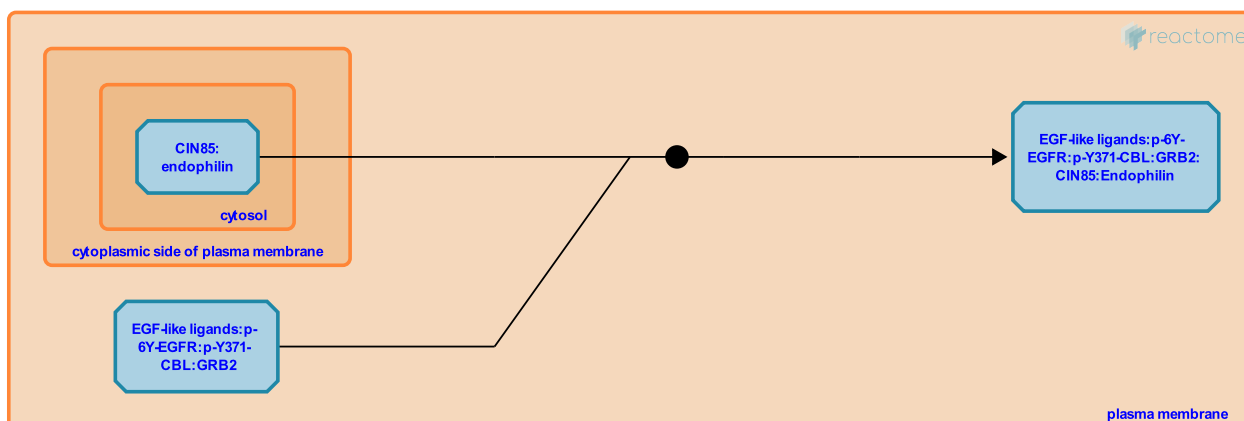

This event has been computationally inferred from an event that has been demonstrated in another species.

The inference is based on the homology mapping from PANTHER. Briefly, reactions for which all involved PhysicalEntities (in input, output and catalyst) have a mapped orthologue/paralogue (for complexes at least 75% of components must have a mapping) are inferred to the other species. High level events are also inferred for these events to allow for easier navigation.

[More details and caveats of the event inference in Reactome.](#) For details on PANTHER see also: <http://www.pantherdb.org/about.jsp>

Followed by: [EGFR binds EPS15, EPN1, EPS15L1](#)

EGFR non-clathrin mediated endocytosis ↗

Location: [EGFR downregulation](#)

Stable identifier: R-BTA-183072

Type: binding

Compartments: plasma membrane, cytosol

Inferred from: [EGFR non-clathrin mediated endocytosis \(Homo sapiens\)](#)

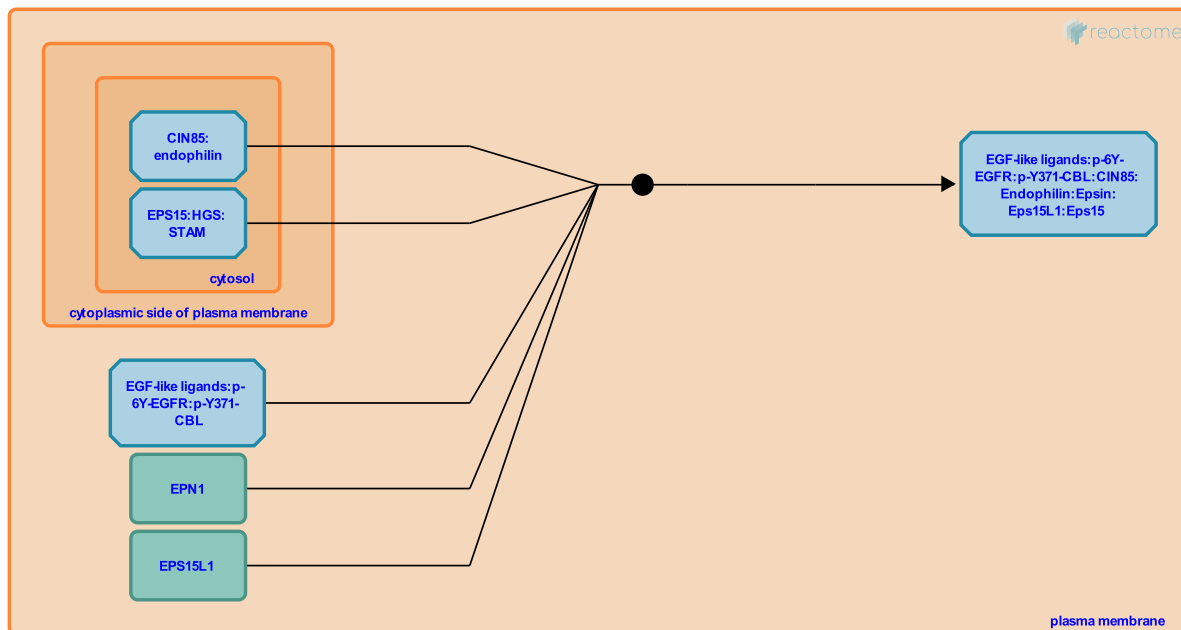

This event has been computationally inferred from an event that has been demonstrated in another species.

The inference is based on the homology mapping from PANTHER. Briefly, reactions for which all involved PhysicalEntities (in input, output and catalyst) have a mapped orthologue/paralogue (for complexes at least 75% of components must have a mapping) are inferred to the other species. High level events are also inferred for these events to allow for easier navigation.

[More details and caveats of the event inference in Reactome.](#) For details on PANTHER see also: <http://www.pantherdb.org/about.jsp>

Followed by: [Sprouty sequesters CBL away from active EGFR, CBL-mediated ubiquitination of CIN85](#)

CBL ubiquitinates Sprouty ↗

Location: EGFR downregulation

Stable identifier: R-BTA-183051

Type: transition

Compartments: plasma membrane, cytosol

Inferred from: CBL ubiquitinates Sprouty (Homo sapiens)

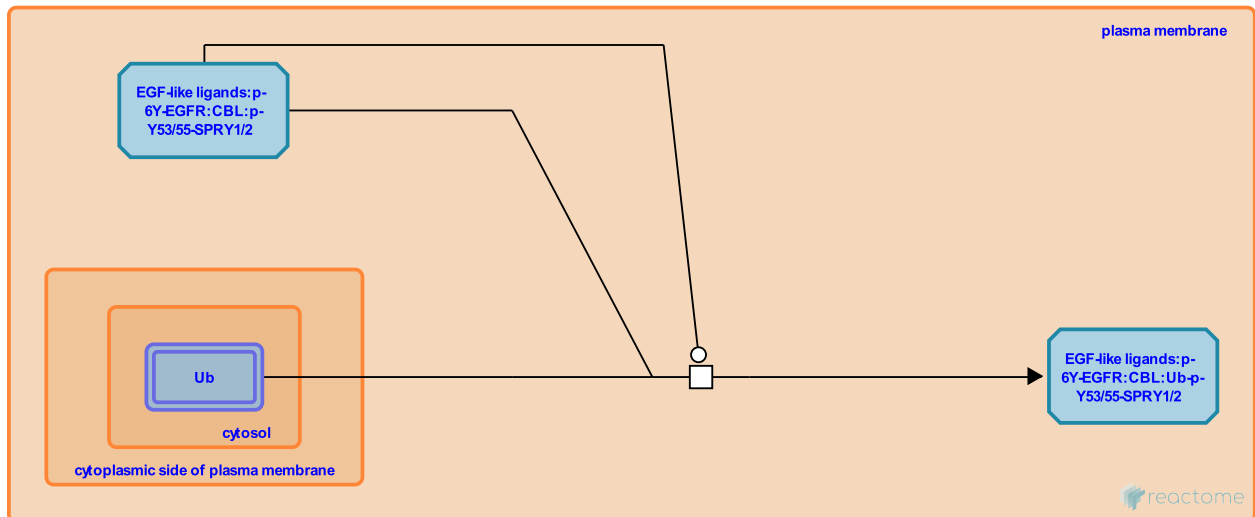

This event has been computationally inferred from an event that has been demonstrated in another species.

The inference is based on the homology mapping from PANTHER. Briefly, reactions for which all involved PhysicalEntities (in input, output and catalyst) have a mapped orthologue/paralogue (for complexes at least 75% of components must have a mapping) are inferred to the other species. High level events are also inferred for these events to allow for easier navigation.

[More details and caveats of the event inference in Reactome.](https://www.reactome.org) For details on PANTHER see also: <http://www.pantherdb.org/about.jsp>

CBL-mediated ubiquitination of CIN85 ↗

Location: [EGFR downregulation](#)

Stable identifier: R-BTA-182986

Type: transition

Compartments: plasma membrane, cytosol

Inferred from: [CBL-mediated ubiquitination of CIN85 \(Homo sapiens\)](#)

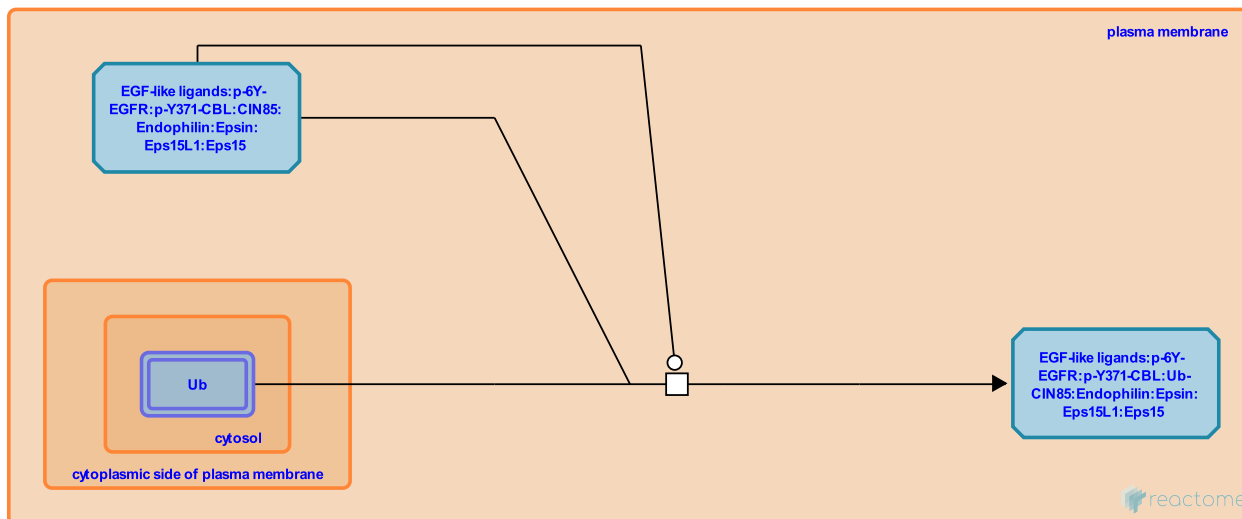

This event has been computationally inferred from an event that has been demonstrated in another species.

The inference is based on the homology mapping from PANTHER. Briefly, reactions for which all involved PhysicalEntities (in input, output and catalyst) have a mapped orthologue/paralogue (for complexes at least 75% of components must have a mapping) are inferred to the other species. High level events are also inferred for these events to allow for easier navigation.

[More details and caveats of the event inference in Reactome.](#) For details on PANTHER see also: <http://www.pantherdb.org/about.jsp>

Preceded by: [EGFR non-clathrin mediated endocytosis](#)

Sprouty sequesters CBL away from active EGFR ↗

Location: [EGFR downregulation](#)

Stable identifier: R-BTA-182990

Type: binding

Compartments: plasma membrane

Inferred from: [Sprouty sequesters CBL away from active EGFR \(Homo sapiens\)](#)

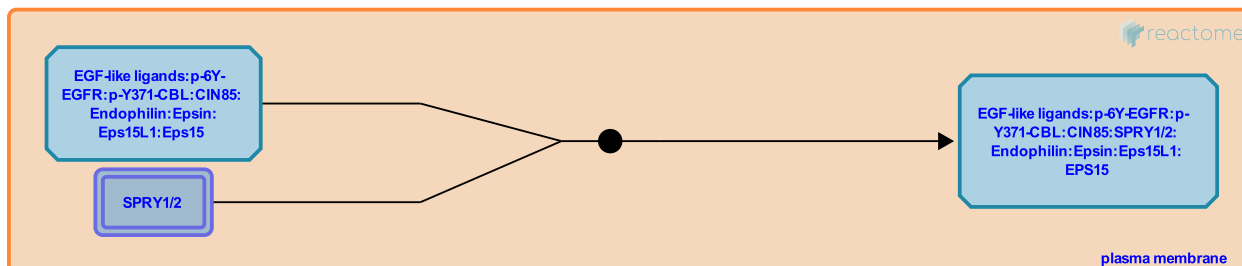

This event has been computationally inferred from an event that has been demonstrated in another species.

The inference is based on the homology mapping from PANTHER. Briefly, reactions for which all involved PhysicalEntities (in input, output and catalyst) have a mapped orthologue/paralogue (for complexes at least 75% of components must have a mapping) are inferred to the other species. High level events are also inferred for these events to allow for easier navigation.

[More details and caveats of the event inference in Reactome.](#) For details on PANTHER see also: <http://www.pantherdb.org/about.jsp>

Preceded by: [EGFR non-clathrin mediated endocytosis](#)

EGFR binds EPS15, EPN1, EPS15L1 ↗

Location: [EGFR downregulation](#)

Stable identifier: R-BTA-8867044

Type: binding

Compartments: plasma membrane

Inferred from: [EGFR binds EPS15, EPN1, EPS15L1 \(Homo sapiens\)](#)

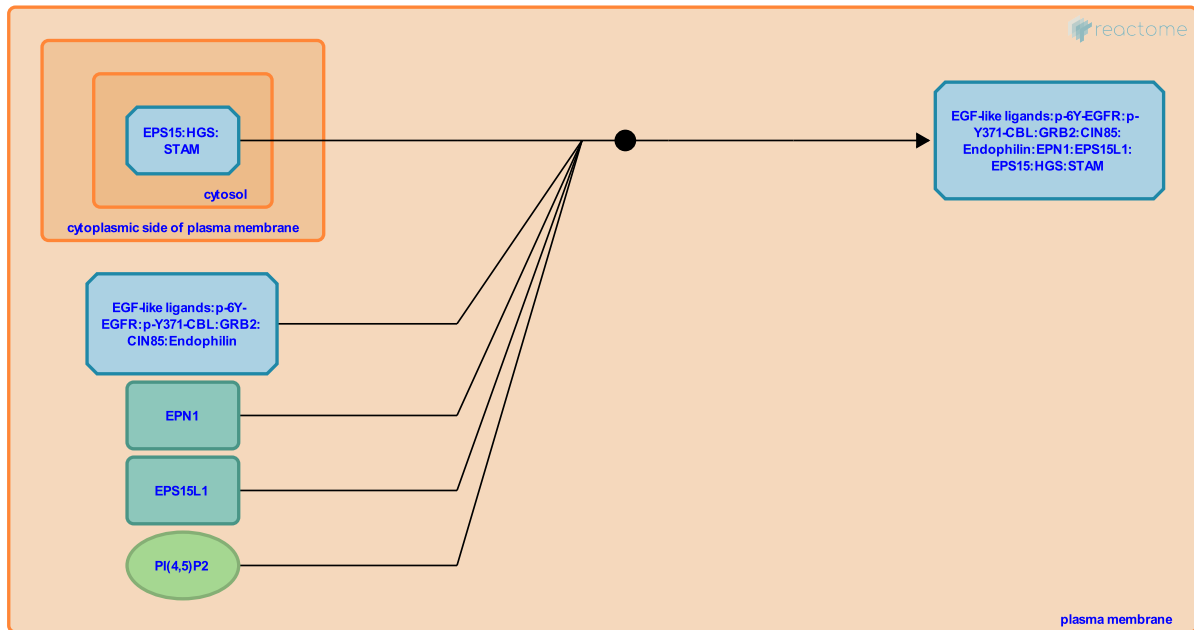

This event has been computationally inferred from an event that has been demonstrated in another species.

The inference is based on the homology mapping from PANTHER. Briefly, reactions for which all involved PhysicalEntities (in input, output and catalyst) have a mapped orthologue/paralogue (for complexes at least 75% of components must have a mapping) are inferred to the other species. High level events are also inferred for these events to allow for easier navigation.

[More details and caveats of the event inference in Reactome.](#) For details on PANTHER see also: <http://www.pantherdb.org/about.jsp>

Preceded by: [Assembly of EGFR complex in clathrin-coated vesicles](#)

Followed by: [EGFR phosphorylates EPS15](#)

EGFR phosphorylates EPS15 ↗

Location: [EGFR downregulation](#)

Stable identifier: R-BTA-8867041

Type: transition

Compartments: plasma membrane

Inferred from: [EGFR phosphorylates EPS15 \(Homo sapiens\)](#)

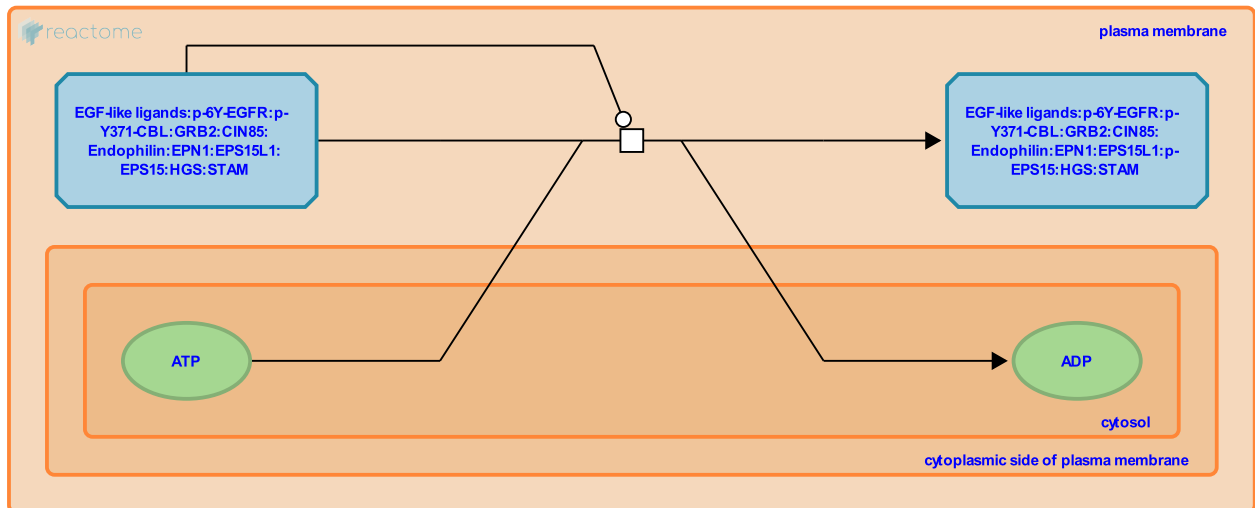

This event has been computationally inferred from an event that has been demonstrated in another species.

The inference is based on the homology mapping from PANTHER. Briefly, reactions for which all involved PhysicalEntities (in input, output and catalyst) have a mapped orthologue/paralogue (for complexes at least 75% of components must have a mapping) are inferred to the other species. High level events are also inferred for these events to allow for easier navigation.

[More details and caveats of the event inference in Reactome.](#) For details on PANTHER see also: <http://www.pantherdb.org/about.jsp>

Preceded by: [EGFR binds EPS15, EPN1, EPS15L1](#)

Followed by: [PTPN3 dephosphorylates EPS15](#)

PTPN3 dephosphorylates EPS15 ↗

Location: [EGFR downregulation](#)

Stable identifier: R-BTA-8867047

Type: transition

Compartments: plasma membrane

Inferred from: [PTPN3 dephosphorylates EPS15 \(Homo sapiens\)](#)

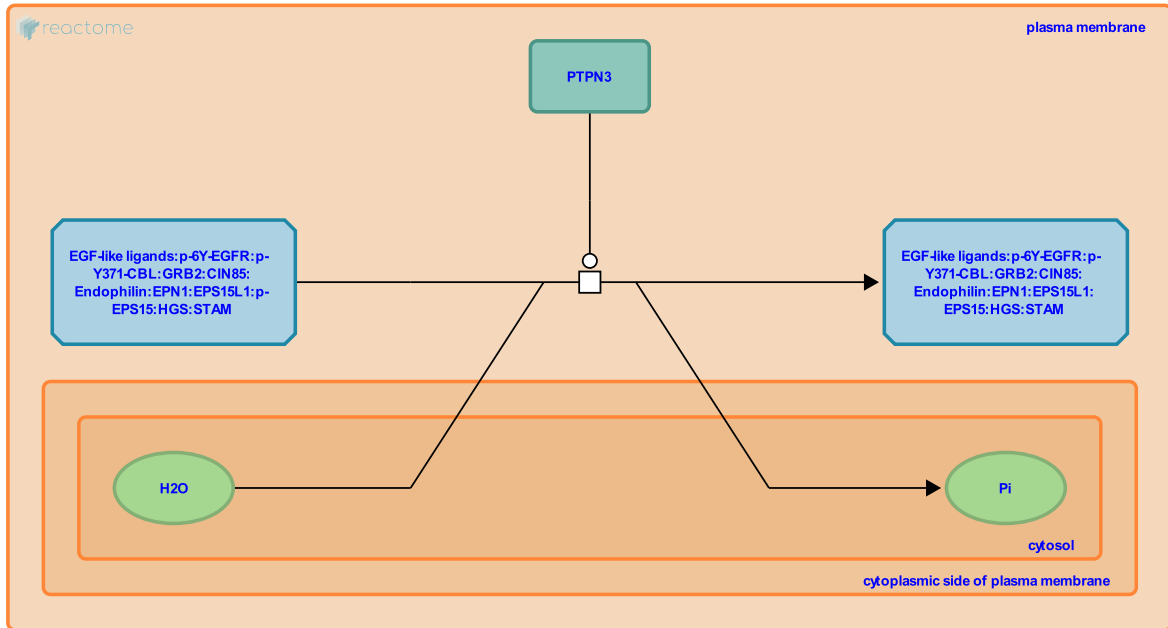

This event has been computationally inferred from an event that has been demonstrated in another species.

The inference is based on the homology mapping from PANTHER. Briefly, reactions for which all involved PhysicalEntities (in input, output and catalyst) have a mapped orthologue/paralogue (for complexes at least 75% of components must have a mapping) are inferred to the other species. High level events are also inferred for these events to allow for easier navigation.

[More details and caveats of the event inference in Reactome.](#) For details on PANTHER see also: <http://www.pantherdb.org/about.jsp>

Preceded by: [EGFR phosphorylates EPS15](#)

Table of Contents

Introduction	1
☒ EGFR downregulation	2
↳ Binding of CBL to EGFR	3
↳ Phosphorylation of CBL (EGFR:CBL)	4
↳ CBL binds and ubiquitinates phosphorylated Sprouty	5
↳ Ubiquitination of stimulated EGFR (CBL)	6
↳ CBL binds to GRB2	7
↳ Localization of CBL:GRB2 to the membrane	8
↳ Phosphorylation of CBL (EGFR:GRB2:CBL)	9
↳ Ubiquitination of stimulated EGFR (CBL:GRB2)	10
☒ Sprouty lures CBL away from EGFR	11
↳ CDC42:GTP binds CBL:Beta-Pix	12
↳ Beta-Pix:CDC42:GTP binds CBL in EGF:p-6Y-EGFR:CBL:CIN85	13
↳ CIN85 dissociates from EGF:p-6Y-EGFR:CBL:Beta-Pix:CDC42:GTP:CIN85	14
↳ CBL escapes CDC42-mediated inhibition by down-regulating the adaptor molecule Beta-Pix	15
↳ Assembly of EGFR complex in clathrin-coated vesicles	16
↳ EGFR non-clathrin mediated endocytosis	17
↳ CBL ubiquitinates Sprouty	18
↳ CBL-mediated ubiquitination of CIN85	19
↳ Sprouty sequesters CBL away from active EGFR	20
↳ EGFR binds EPS15, EPN1, EPS15L1	21
↳ EGFR phosphorylates EPS15	22
↳ PTPN3 dephosphorylates EPS15	23
Table of Contents	24