

Degradation of the extracellular matrix

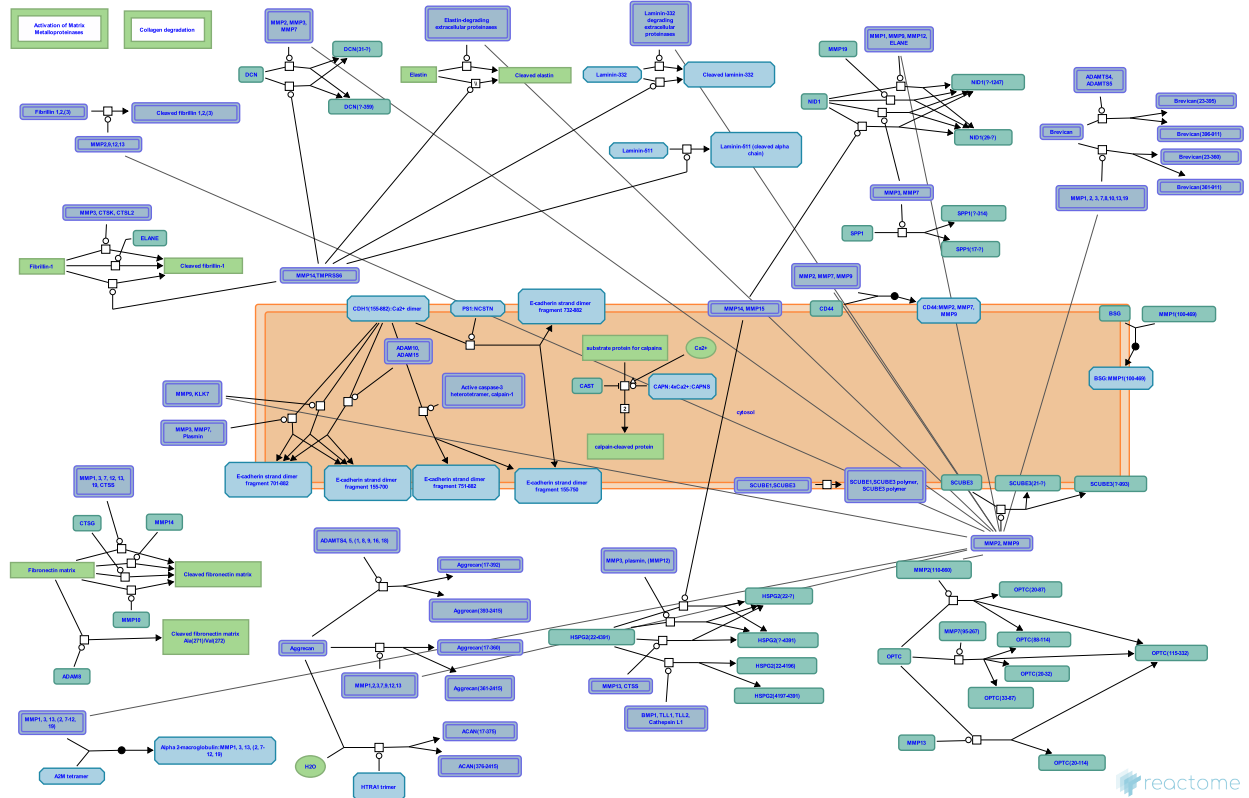

Butler, GS., D'Eustachio, P., Garapati, P V., Jassal, B., Jupe, S., Overall, CM., Ricard-Blum, S., Sorsa, T., Trowsdale, J., Xavier, X., de Bono, B.

European Bioinformatics Institute, New York University Langone Medical Center, Ontario Institute for Cancer Research, Oregon Health and Science University.

The contents of this document may be freely copied and distributed in any media, provided the authors, plus the institutions, are credited, as stated under the terms of [Creative Commons Attribution 4.0 International \(CC BY 4.0\) License](https://creativecommons.org/licenses/by/4.0/). For more information see our [license](https://reactome.org/licenses/).

This is just an excerpt of a full-length report for this pathway. To access the complete report, please download it at the [Reactome Textbook](https://reactome.org/textbook/).

18/05/2024

Introduction

Reactome is open-source, open access, manually curated and peer-reviewed pathway database. Pathway annotations are authored by expert biologists, in collaboration with Reactome editorial staff and cross-referenced to many bioinformatics databases. A system of evidence tracking ensures that all assertions are backed up by the primary literature. Reactome is used by clinicians, geneticists, genomics researchers, and molecular biologists to interpret the results of high-throughput experimental studies, by bioinformaticians seeking to develop novel algorithms for mining knowledge from genomic studies, and by systems biologists building predictive models of normal and disease variant pathways.

The development of Reactome is supported by grants from the US National Institutes of Health (P41 HG003751), University of Toronto (CFREF Medicine by Design), European Union (EU STRP, EMI-CD), and the European Molecular Biology Laboratory (EBI Industry program).

Literature references

- Fabregat, A., Sidiropoulos, K., Viteri, G., Forner, O., Marin-Garcia, P., Arnau, V. et al. (2017). Reactome pathway analysis: a high-performance in-memory approach. *BMC bioinformatics*, 18, 142. [↗](#)
- Sidiropoulos, K., Viteri, G., Sevilla, C., Jupe, S., Webber, M., Orlic-Milacic, M. et al. (2017). Reactome enhanced pathway visualization. *Bioinformatics*, 33, 3461-3467. [↗](#)
- Fabregat, A., Jupe, S., Matthews, L., Sidiropoulos, K., Gillespie, M., Garapati, P. et al. (2018). The Reactome Pathway Knowledgebase. *Nucleic Acids Res*, 46, D649-D655. [↗](#)
- Fabregat, A., Korninger, F., Viteri, G., Sidiropoulos, K., Marin-Garcia, P., Ping, P. et al. (2018). Reactome graph database: Efficient access to complex pathway data. *PLoS computational biology*, 14, e1005968. [↗](#)

Reactome database release: 88

This document contains 3 pathways and 44 reactions ([see Table of Contents](#))

Activation of Matrix Metalloproteinases ↗

Location: Degradation of the extracellular matrix

Stable identifier: R-HSA-1592389

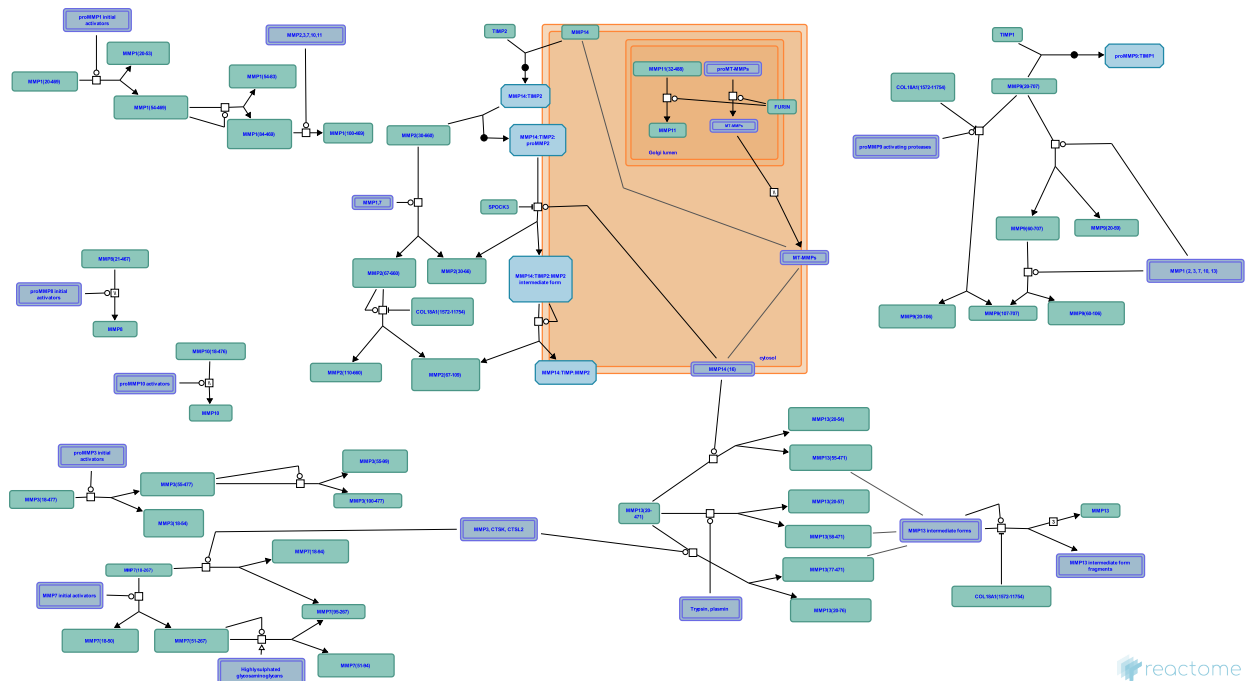

The matrix metalloproteinases (MMPs), previously known as matrixins, are classically known to be involved in the turnover of extracellular matrix (ECM) components. However, recent high throughput proteomics analyses have revealed that ~80% of MMP substrates are non-ECM proteins including cytokines, growth factor binding proteins, and receptors. It is now clear that MMPs regulate ECM turnover not only by cleaving ECM components, but also by the regulation of cell signalling, and that some MMPs are beneficial and may be drug anti-targets. Thus, MMPs have important roles in many processes including embryo development, morphogenesis, tissue homeostasis and remodeling. They are implicated in several diseases such as arthritis, periodontitis, glomerulonephritis, atherosclerosis, tissue ulceration, and cancer cell invasion and metastasis. All MMPs are synthesized as proenzymes. Alternate splice forms are known, leading to nuclear localization of select MMPs. Most are secreted from the cell, or in the case of membrane type (MT) MMPs become plasma membrane associated, as inactive proenzymes. Their subsequent activation is a key regulatory step, with requirements specific to MMP subtype.

Literature references

Butler, GS., Overall, CM. (2009). Updated biological roles for matrix metalloproteinases and new "intracellular" substrates revealed by degradomics. *Biochemistry*, 48, 10830-45. ↗

Butler, GS., Overall, CM., Morrison, CJ., Rodríguez, D. (2009). Matrix metalloproteinase proteomics: substrates, targets, and therapy. *Curr Opin Cell Biol*, 21, 645-53. ↗

Overall, CM., Morrison, CJ., Rodríguez, D. (2010). Matrix metalloproteinases: what do they not do? New substrates and biological roles identified by murine models and proteomics. *Biochim Biophys Acta*, 1803, 39-54. ↗

Opendakker, G., Van den Steen, PE., Cauwe, B. (2007). The biochemical, biological, and pathological kaleidoscope of cell surface substrates processed by matrix metalloproteinases. *Crit Rev Biochem Mol Biol*, 42, 113-85. ↗

Woessner, J., Nagase, H. (2000). Matrix Metalloproteinases and TIMPs. *Oxford University Press*.

Editions

2011-09-09	Authored	Jupe, S.
2012-02-21	Edited	Jupe, S.
2012-02-28	Reviewed	Overall, CM., Butler, GS.

places in the chain. MMP14, a membrane-associated MMP also known as Membrane-type matrix metalloproteinase 1 (MT-MMP1), is able to cleave collagen types I, II and III (Ohuchi et al. 1997).

Literature references

Shapiro, SD. (1998). Matrix metalloproteinase degradation of extracellular matrix: biological consequences. *Curr Opin Cell Biol*, 10, 602-8. [↗](#)

Huber, O., Bommert, K., Steinhilber, U., Badock, V., Tauber, R., Weiske, J. (2001). Cleavage and shedding of E-cadherin after induction of apoptosis. *J. Biol. Chem.*, 276, 4972-80. [↗](#)

Uhlen-Hansen, L., Winberg, JO., Hadler-Olsen, E., Fadnes, B., Sylte, I. (2011). Regulation of matrix metalloproteinase activity in health and disease. *FEBS J*, 278, 28-45. [↗](#)

Editions

2011-07-12	Authored	Jupe, S.
2012-10-08	Reviewed	Sorsa, T.
2012-11-12	Edited	Jupe, S.

Elastin degradation by elastin-degrading extracellular proteinases ↗

Location: [Degradation of the extracellular matrix](#)

Stable identifier: R-HSA-1566962

Type: transition

Compartments: extracellular region

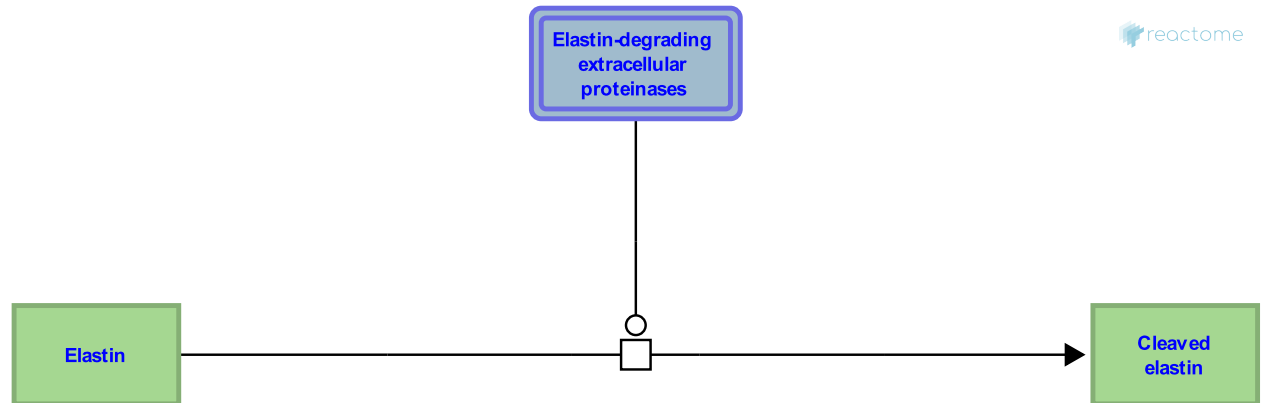

The elastin component of elastic fibres is degraded to soluble fragments by MMP2 (Murphy et al. 1991), MMP7 (Quantin et al. 1989, Murphy et al. 1991), MMP9 (Murphy et al. 1991, Katsuda et al. 1994) and MMP12 (macrophage elastase) (Shapiro et al. 1993, Taddese et al. 2008), and to a limited extent by MMP3 and 10 (Murphy et al. 1991). In addition, elastin is a substrate for neutrophil elastase (Reilly & Travis 1980).

Eighty-nine tropoelastin cleavage sites were identified for MMP-12, whereas MMP-7 and MMP-9 were found to cleave at only 58 and 63 sites, respectively (Heinz et al. 2010).

Literature references

Docherty, AJ., Ward, RV., Cockett, MI., Murphy, G. (1991). Matrix metalloproteinase degradation of elastin, type IV collagen and proteoglycan. A quantitative comparison of the activities of 95 kDa and 72 kDa gelatinases, stromelysins-1 and -2 and punctuated metalloproteinase (PUMP). *Biochem J*, 277, 277-9. ↗

Kobayashi, DK., Ley, TJ., Shapiro, SD. (1993). Cloning and characterization of a unique elastolytic metalloproteinase produced by human alveolar macrophages. *J Biol Chem*, 268, 23824-9. ↗

Editions

2012-08-08	Authored	Jupe, S.
2013-08-13	Edited	Jupe, S.
2013-08-13	Reviewed	Ricard-Blum, S.

Elastin degradation by MMP14 [↗](#)

Location: [Degradation of the extracellular matrix](#)

Stable identifier: R-HSA-2514790

Type: omitted

Compartments: plasma membrane, extracellular region

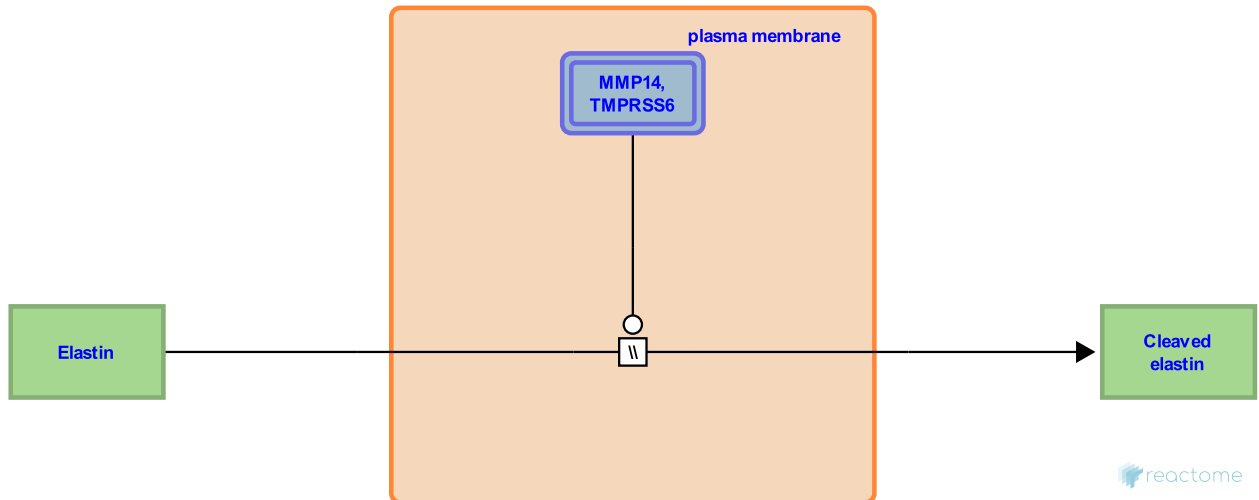

Elastin degradation is regulated by the membrane-associated matrix metalloproteinase MMP14 (Xiong et al. 2009) and associated with aneurisms.

Literature references

Xiong, W., Knispel, R., Weiss, SJ., MacTaggart, J., Greiner, TC., Baxter, BT. (2009). Membrane-type 1 matrix metalloproteinase regulates macrophage-dependent elastolytic activity and aneurysm formation in vivo. *J. Biol. Chem.*, 284, 1765-71. [↗](#)

Editions

2012-08-08	Authored	Jupe, S.
2013-08-13	Edited	Jupe, S.
2013-08-13	Reviewed	Ricard-Blum, S.

Fibrillin 1, 2,(3) degradation by MMP2, 9, 12 and 13 [↗](#)

Location: [Degradation of the extracellular matrix](#)

Stable identifier: R-HSA-2485148

Type: transition

Compartments: extracellular region

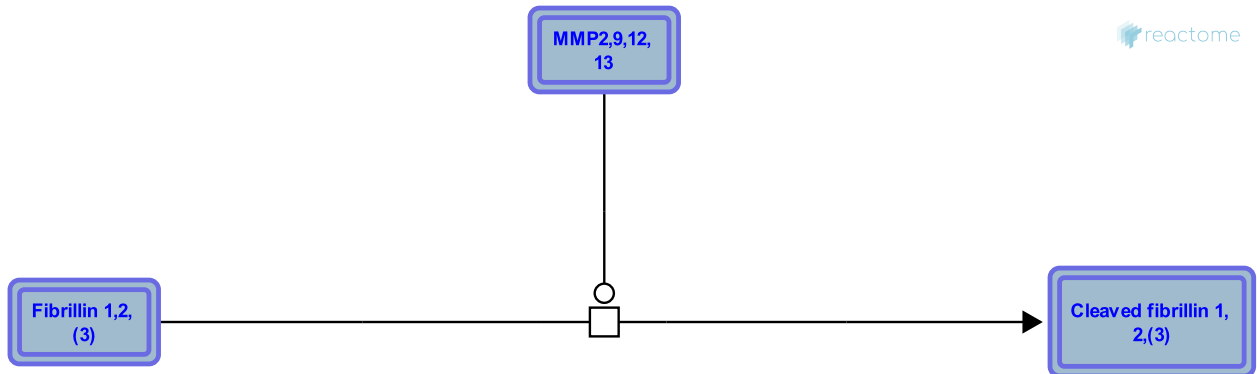

All mammals have three fibrillin genes (Davis & Summers 2012). Fibrillin-3 arose as a duplication of fibrillin-2 that did not occur in the rodent lineage. Fibrillin-1 is the major structural component of microfibrils (Kielty et al. 2005). Fibrillin-2 is expressed earlier in development than fibrillin-1 and may be important for elastic fiber formation (Zhang et al. 1994). Fibrillin-3 was isolated from and is predominantly expressed in brain; it is not known whether it forms microfibrils (Corson et al. 2004). Fibrillin-1 and -2 are degraded by MMP2, 9, 12 and 13 (Ashworth et al. 1999, Hindson et al. 1999). Fibrillin-1 is additionally degraded by MMP3 (Ashworth et al. 1999), the membrane-associated MMP14 (Ashworth et al. 1999), neutrophil elastase (ELANE) (Kielty et al. 1994), cathepsin L2 (V) and cathepsin K (Kirschner et al. 2011).

Literature references

Shuttleworth, CA., Hindson, VJ., Cunliffe, S., Kielty, CM., Ashworth, JL., Rock, MJ. (1999). Fibrillin degradation by matrix metalloproteinases: identification of amino- and carboxy-terminal cleavage sites. *FEBS Lett.*, 452, 195-8. [↗](#)

Shuttleworth, CA., Murphy, G., Sherratt, MJ., Kielty, CM., Ashworth, JL., Rock, MJ. et al. (1999). Fibrillin degradation by matrix metalloproteinases: implications for connective tissue remodelling. *Biochem. J.*, 340, 171-81. [↗](#)

Editions

2012-08-08	Authored	Jupe, S.
2013-08-13	Edited	Jupe, S.
2013-08-13	Reviewed	Ricard-Blum, S.

Fibrillin-1 degradation by MMP3, CTSK, CTSL2 [↗](#)

Location: [Degradation of the extracellular matrix](#)

Stable identifier: R-HSA-2514772

Type: transition

Compartments: extracellular region

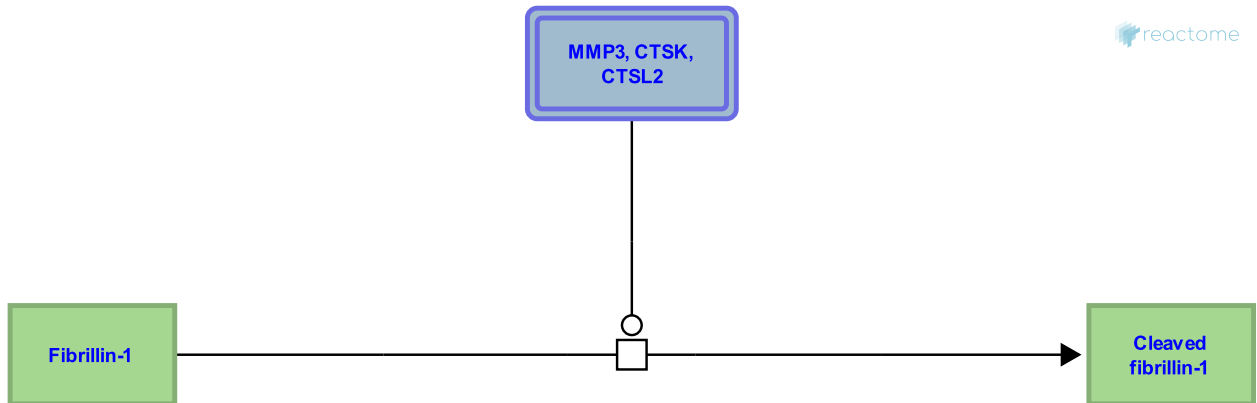

Fibrillin-1 can be degraded by MMP3 (Ashworth et al. 1999) and cathepsins K and L2 (V) (Kirschner et al. 2011).

Literature references

Shuttleworth, CA., Murphy, G., Sherratt, MJ., Kielty, CM., Ashworth, JL., Rock, MJ. et al. (1999). Fibrillin degradation by matrix metalloproteinases: implications for connective tissue remodelling. *Biochem. J.*, 340, 171-81. [↗](#)

Brömme, D., Hubmacher, D., Fagotto-Kaufmann, C., Kaur, J., Iyengar, G., Bartels, R. et al. (2011). Classical and neonatal Marfan syndrome mutations in fibrillin-1 cause differential protease susceptibilities and protein function. *J. Biol. Chem.*, 286, 32810-23. [↗](#)

Editions

2012-08-08	Authored	Jupe, S.
2013-08-13	Edited	Jupe, S.
2013-08-13	Reviewed	Ricard-Blum, S.

Fibrillin-1 degradation by MMP14 [↗](#)

Location: [Degradation of the extracellular matrix](#)

Stable identifier: R-HSA-2514831

Type: transition

Compartments: plasma membrane, extracellular region

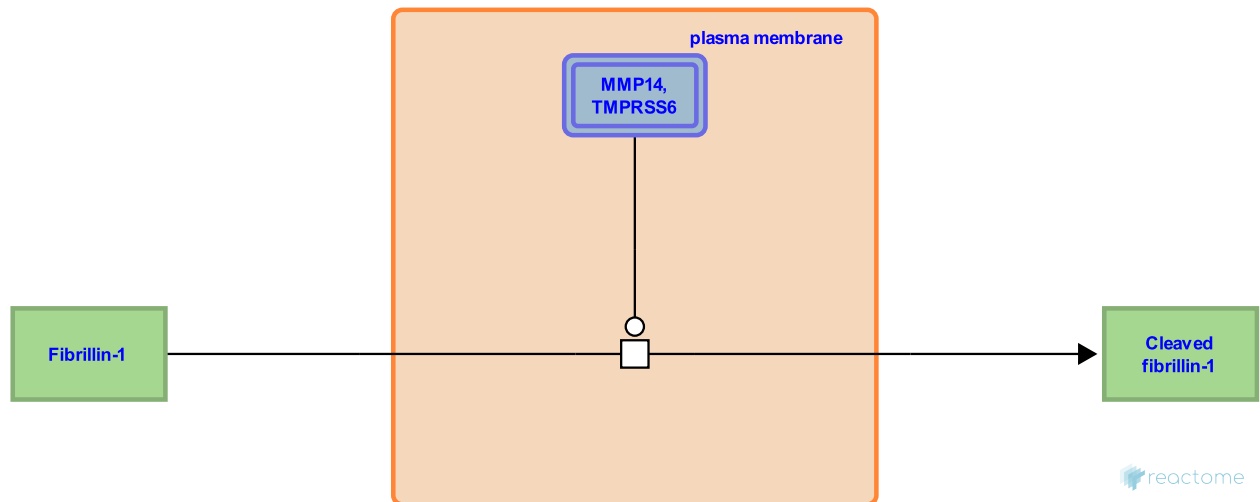

Fibrillin-1 is the major structural component of microfibrils (Kielty et al. 2005). It can be degraded by the membrane-associated MMP14 (Ashworth et al. 1999).

Literature references

Shuttleworth, CA., Murphy, G., Sherratt, MJ., Kielty, CM., Ashworth, JL., Rock, MJ. et al. (1999). Fibrillin degradation by matrix metalloproteinases: implications for connective tissue remodelling. *Biochem. J.*, 340, 171-81. [↗](#)

Editions

2012-08-08	Authored	Jupe, S.
2013-08-13	Edited	Jupe, S.
2013-08-13	Reviewed	Ricard-Blum, S.

Fibrillin-1 degradation by ELANE ↗

Location: [Degradation of the extracellular matrix](#)

Stable identifier: R-HSA-2514823

Type: transition

Compartments: extracellular region

Inferred from: [Degradation of fibrillin-1 by Elane \(Bos taurus\)](#)

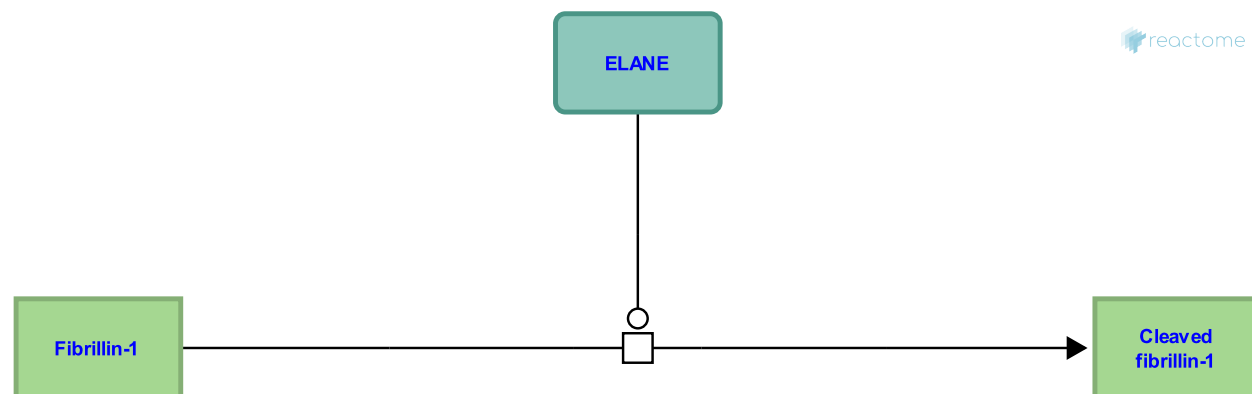

Fibrillin-1, the major structural component of microfibrils (Kielty et al. 2005), can be degraded by neutrophil elastase (ELANE) (Kielty et al. 1994).

Editions

2012-08-08	Authored	Jupe, S.
2013-08-13	Edited	Jupe, S.
2013-08-13	Reviewed	Ricard-Blum, S.

Fibronectin degradation by MMP1, 3, 7, 12, 13, 19, CTSS ↗

Location: [Degradation of the extracellular matrix](#)

Stable identifier: R-HSA-1566981

Type: transition

Compartments: extracellular region

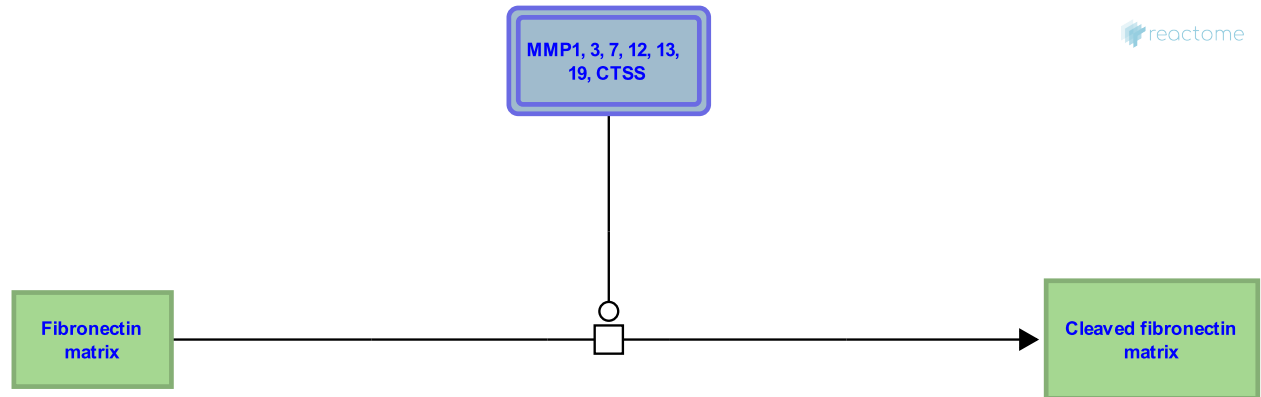

MMP1 can degrade fibronectin (Fukai et al. 1995), as can MMP3 (Gunja-Smith et al. 1985, Nicholson et al. 1989, Wilhelm et al. 1993, Fukai et al. 1995), MMP7 (Quantin et al. 1989, Miyazaki et al. 1990, Fukai et al. 1995, von Bredow et al. 1995), MMP10 (Nicholson et al. 1989), MMP12 (Gronski et al. 1997), MMP13 (Knauper et al. 1997), MMP14 (Shi & Sottile 2011) and 19 (Stracke et al. 2000). Cathepsin S is able to degrade fibronectin (Taleb et al. 2006). Studies have shown that fibronectin turnover is not prevented by protease inhibitors (Sottile & Hocking 2002) suggesting that caveolin-1-mediated endocytosis and intracellular degradation are involved (Salicioni et al. 2002, Sottile & Chandler 2004).

Literature references

- Fukai, F., Yajima, H., Ohtaki, M., Miyazaki, K., Ishii, T., Katayama, T. et al. (1995). Release of biological activities from quiescent fibronectin by a conformational change and limited proteolysis by matrix metalloproteinases. *Biochemistry*, 34, 11453-9. ↗
- Murphy, G., Knäuper, V., López-Otin, C., Stracke, JO., Hutton, M., Stewart, M. et al. (2000). Biochemical characterization of the catalytic domain of human matrix metalloproteinase 19. Evidence for a role as a potent basement membrane degrading enzyme. *J. Biol. Chem.*, 275, 14809-16. ↗
- Taleb, S., Clément, K., Cancellato, R., Lacasa, D. (2006). Cathepsin s promotes human preadipocyte differentiation: possible involvement of fibronectin degradation. *Endocrinology*, 147, 4950-9. ↗
- Kobayashi, DK., Gronski TJ, Jr., Martin, RL., Van Wart, HE., Holman, MC., Huber, M. et al. (1997). Hydrolysis of a broad spectrum of extracellular matrix proteins by human macrophage elastase. *J Biol Chem*, 272, 12189-94. ↗
- O'Shea, M., Cowell, S., Morris, H., Smith, B., Zardi, L., López-Otin, C. et al. (1997). The role of the C-terminal domain of human collagenase-3 (MMP-13) in the activation of procollagenase-3, substrate specificity, and tissue inhibitor of metalloproteinase interaction. *J Biol Chem*, 272, 7608-16. ↗

Editions

2012-08-08	Authored	Jupe, S.
2013-08-13	Edited	Jupe, S.
2013-08-13	Reviewed	Ricard-Blum, S.

Fibronectin degradation by MMP10 ↗

Location: [Degradation of the extracellular matrix](#)

Stable identifier: R-HSA-2533944

Type: transition

Compartments: extracellular region

Inferred from: [Fibronectin degradation by MMP10 \(Bos taurus\)](#)

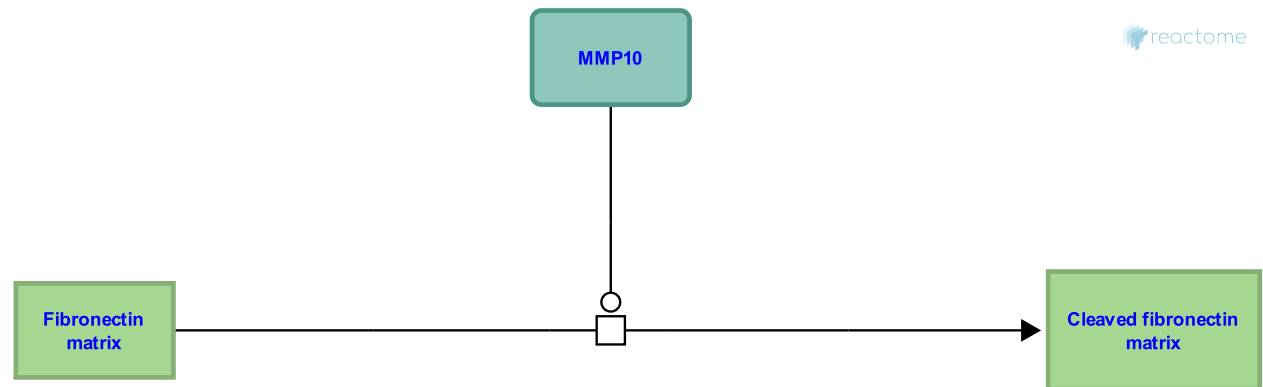

MMP10 can degrade fibronectin (Nicholson et al. 1989).

Editions

2012-08-08	Authored	Jupe, S.
2013-08-13	Edited	Jupe, S.
2013-08-13	Reviewed	Ricard-Blum, S.

Fibronectin degradation by MMP14 [↗](#)

Location: [Degradation of the extracellular matrix](#)

Stable identifier: R-HSA-2533950

Type: transition

Compartments: plasma membrane, extracellular region

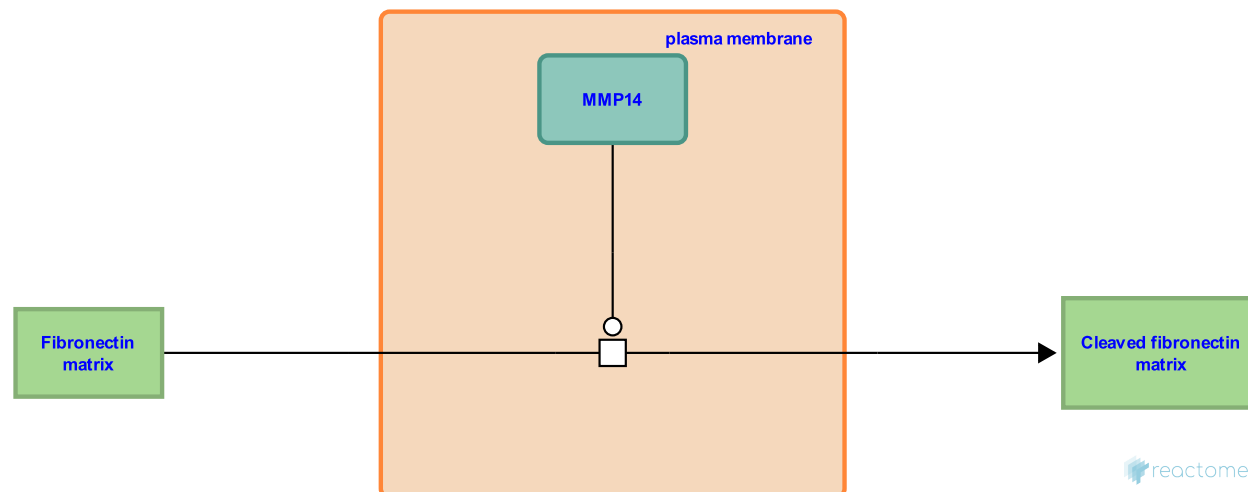

MMP14 (MT1-MMP) can degrade fibronectin (Shi & Sottile 2011; Takino et al. 2011). Studies have shown that fibronectin turnover is not prevented by protease inhibitors (Sottile & Hocking 2002) and suggest that caveolin-1-mediated endocytosis and intracellular degradation are involved (Salicioni et al. 2002, Sottile & Chandler 2004).

Literature references

Sekiguchi, K., Manabe, R., Takino, T., Sato, H., Domoto, T., Nagao, R. (2011). Membrane-type 1 matrix metalloproteinase regulates fibronectin assembly to promote cell motility. *FEBS Lett*, 585, 3378-84. [↗](#)

Sottile, J., Shi, F. (2011). MT1-MMP regulates the turnover and endocytosis of extracellular matrix fibronectin. *J. Cell. Sci.*, 124, 4039-50. [↗](#)

Editions

2012-08-08	Authored	Jupe, S.
2013-08-13	Edited	Jupe, S.
2013-08-13	Reviewed	Ricard-Blum, S.

Fibronectin degradation by CTSG ↗

Location: [Degradation of the extracellular matrix](#)

Stable identifier: R-HSA-3785684

Type: transition

Compartments: plasma membrane

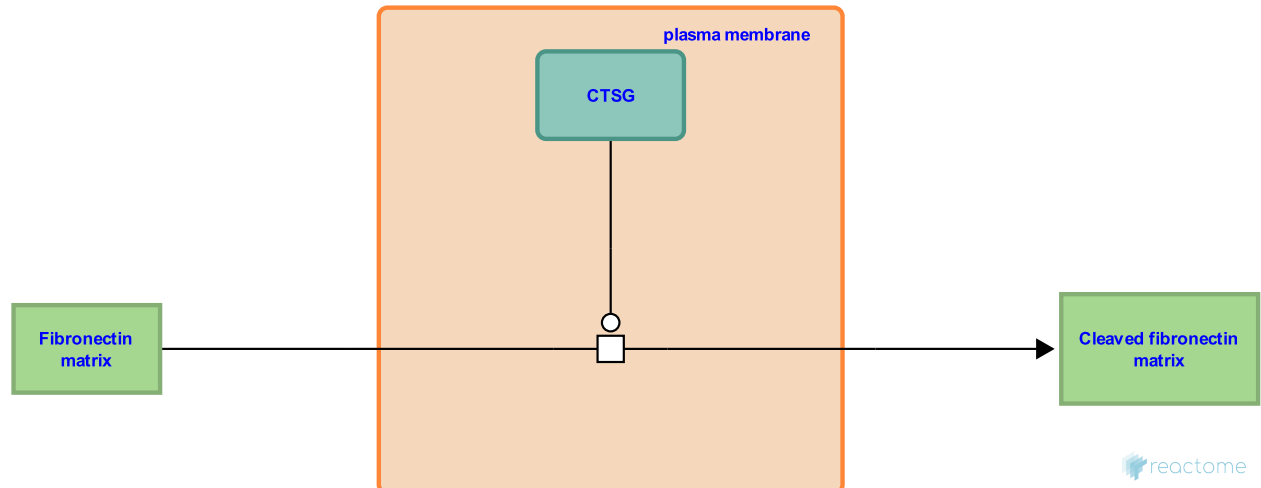

Plasma fibronectin (FN1) is degraded by cathepsin G (CTSG) into a characteristic pattern of gelatin-binding peptides of $M_r = 64000$, 40000 , and 30000 (Vartio et al. 1981, Vartio 1982). CTSG is activated by UV exposure and can activate matrix metalloproteinases MMP1 and MMP2, but increased levels of MMP activity did not correlate with increased FN degradation in normal human fibroblasts (NHF) following exposure to UVB (50 mJ/cm^2) irradiation, while addition of CTSG inhibitor decreased FN degradation, suggesting that CTSG is directly responsible for FN1 degradation (Son et al. 2009).

Literature references

Vartio, T. (1982). Characterization of the binding domains in the fragments cleaved by cathepsin G from human plasma fibronectin. *Eur. J. Biochem.*, 123, 223-33. ↗

Editions

2012-08-08	Authored	Jupe, S.
2013-08-13	Edited	Jupe, S.
2013-08-13	Reviewed	Ricard-Blum, S.

Fibronectin degradation by ADAM8 [↗](#)

Location: [Degradation of the extracellular matrix](#)

Stable identifier: R-HSA-3788061

Type: transition

Compartments: plasma membrane

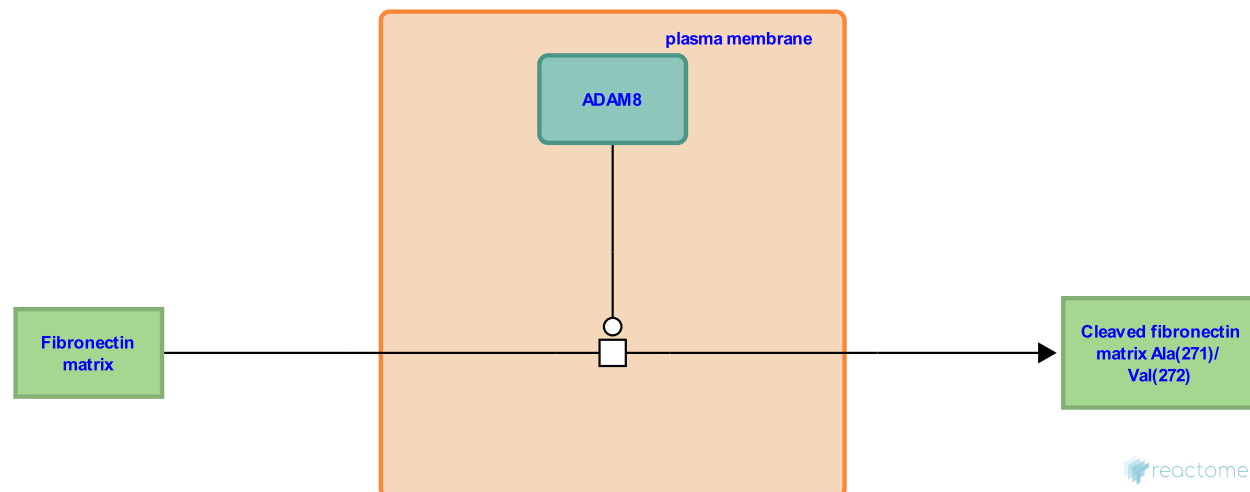

ADAM8 can cleave fibronectin in human cartilage extracts at Ala271/Val272, within a linker region between the fifth and sixth type I domains, producing ~30-kd and ~50–85-kd fragments with distinctive neoepitopes VRAA271 and 272VYQP that are associated with osteoarthritis (Zack et al. 2006, 2009).

Literature references

Griggs, DW., Arner, EC., Leone, JW., Radabaugh, MR., Skepner, AP., Nemirovskiy, OV. et al. (2009). ADAM-8 isolated from human osteoarthritic chondrocytes cleaves fibronectin at Ala(271). *Arthritis Rheum.*, 60, 2704-13. [↗](#)

Editions

2012-08-08	Authored	Jupe, S.
2013-08-13	Edited	Jupe, S.
2013-08-13	Reviewed	Ricard-Blum, S.

Laminin-332 degradation by laminin-322 degrading extracellular proteinases ↗

Location: [Degradation of the extracellular matrix](#)

Stable identifier: R-HSA-1566979

Type: transition

Compartments: extracellular region

Inferred from: [Degradation of laminin-111, -332 by Mmp3, 7, 12, 13, 19, 20 and plasmin \(Mus musculus\)](#)

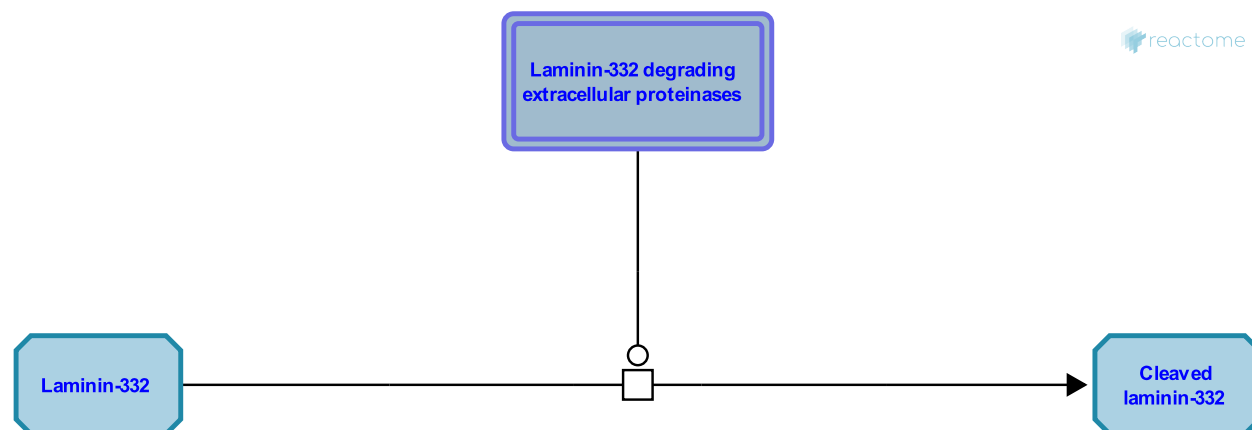

Laminins are an important molecular component of the basement membranes (BMs) in a variety of tissue types. They have a cruciform shape, and are composed of three chains, alpha, beta and gamma., all of which have multiple subtypes. At the ultrastructural level, each laminin trimer appears as a cross-like structure with a large globular domain (LG domain) at the base of the cross. The LG domain is the C-terminal domain of the alpha subunit; it is divided into five homologous subdomains LG1-5 (Sugawara et al. 2008). Keratinocytes of the skin secrete numerous laminin isoforms, including laminin-511 and laminin-332. Laminin-332 undergoes extensive proteolysis following secretion, which is essential for laminin-332 integration into the BM (Rousselle & Beck 2013). The 200 kDa alpha-3 subunit of laminin-332 is cleaved between the LG3-LG4 subdomains to generate a 165 kDa product. The 160 kDa gamma-2 subunit is cleaved at its N-terminus to produce a 105 kDa protein (Marinkovich et al. 1992). Tissue remodeling may lead to further proteolysis of the 105 kDa subunit within the N-terminus giving rise to a 80 kDa protein (Gianelli et al. 1997, Koshikawa et al. 2005). The resulting N-terminal fragment has EGF-like properties and may activate the EGF receptor, inducing cell migration (Schenk et al. 2003). In much of the early literature it is not clear which subunit of the laminin trimer was cleaved, but in vitro studies have revealed specific enzymes involved in the processing of laminin-332 including MMP2, MMP14 (MT1-MMP), and the C-proteinase family of enzymes, especially bone morphogenic protein 1 (BMP1) and mammalian tolloid (mTLD), isoforms 1 and 3 respectively of UniProt P13497 BMP1 (Sugawara et al. 2008, Rousselle & Beck 2013). Many proteases have been demonstrated to degrade specific subunits of laminin-332. The beta-3 chain is degraded by matrix metalloproteinase 14 (MMP14, MT1-MMP, Udayakumar et al. 2003) and MMP7 (Remy et al. 2006). The alpha-3 chain is degraded by plasmin (Goldfinger et al. 1998, 1999) and BMP1 (and its isoform mTLD, Veitch et al. 2003). Laminin gamma-2 chain is degraded by MMP14 (Koshikawa et al. 2000, 2005, Pirilä et al. 2003), MMP2 (Gianelli et al. 1997, Pirilä et al. 2003), MMP3, 12, 13 (Pirilä et al. 2003), 19 (Sadowski et al. 2005), MMP20 (Väänänen et al. 2001, Pirilä et al. 2003), BMP1 (Amano et al. 2000, Kessler et al. 2001) and mTLD (Veitch et al. 2003). Plasmin cleavage of laminin-111 yields fragments with sizes that correspond to the cleavage of the alpha and beta/gamma components (Gutiérrez-Fernández et al. 2009). In this reaction laminin-322 is represented with all 3 component peptides cleaved.

Editions

2012-08-08	Authored	Jupe, S.
2013-08-13	Edited	Jupe, S.
2013-08-13	Reviewed	Ricard-Blum, S.

Laminin-322 degradation by MMP14 ↗

Location: [Degradation of the extracellular matrix](#)

Stable identifier: R-HSA-3791155

Type: transition

Compartments: plasma membrane, extracellular region

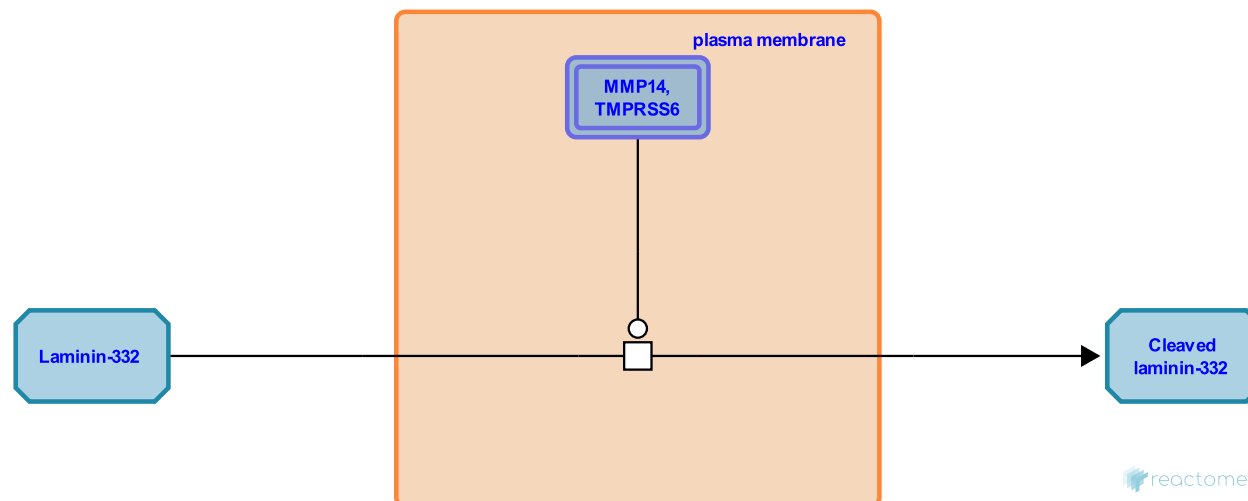

Laminins are an important molecular component of the basement membranes (BMs) in a variety of tissue types. They have a cruciform shape, and are composed of three chains, alpha, beta and gamma., all of which have multiple subtypes. At the ultrastructural level, each laminin trimer appears as a cross-like structure with a large globular domain (LG domain) at the base of the cross. The LG domain is the C-terminal domain of the alpha subunit; it is divided into five homologous subdomains LG1-5 (Sugawara et al. 2008). Keratinocytes of the skin secrete numerous laminin isoforms, including laminin-511 and laminin-332.

Laminin-332 undergoes extensive proteolysis following secretion, which is essential for laminin-332 integration into the BM (Rousselle & Beck 2013). The 200 kDa alpha-3 subunit of laminin-332 is cleaved between the LG3-LG4 subdomains to generate a 165 kDa product. The 160 kDa gamma-2 subunit is cleaved at its N-terminus to produce a 105 kDa protein (Marinkovich et al. 1992). Tissue remodeling may lead to further proteolysis of the 105 kDa subunit within the N-terminus giving rise to a 80 kDa protein (Gianelli et al. 1997, Koshikawa et al. 2005). The resulting N-terminal fragment has EGF-like properties and may activate the EGF receptor, inducing cell migration (Schenk et al. 2003).

In much of the early literature it is not clear which subunit of the laminin trimer was cleaved, but in vitro studies have revealed specific enzymes involved in the processing of laminin-332 including MMP2, MMP14 (MT1-MMP), and the C-proteinase family of enzymes, especially bone morphogenic protein 1 (BMP1) and mammalian tolloid (mTLD), isoforms 1 and 3 respectively of UniProt P13497 BMP1 (Sugawara et al. 2008, Rousselle & Beck 2013).

The beta-3 and gamma-2 chains of laminin-322 are degraded by matrix metalloproteinase 14 (MMP14, MT1-MMP, Udayakumar et al. 2003, Koshikawa et al. 2000, 2005, Pirilä et al. 2003).

Literature references

Bowden, GT., Cress, AE., Chen, ML., Udayakumar, TS., Von Bredow, DC., Bair, EL. et al. (2003). Membrane type-1-matrix metalloproteinase expressed by prostate carcinoma cells cleaves human laminin-5 beta3 chain and induces cell migration. *Cancer Res.*, 63, 2292-9. ↗

Editions

2012-08-08	Authored	Jupe, S.
2013-08-13	Edited	Jupe, S.
2013-08-13	Reviewed	Ricard-Blum, S.

Laminin-511 degradation by MMP14 ↗

Location: [Degradation of the extracellular matrix](#)

Stable identifier: R-HSA-2533874

Type: transition

Compartments: plasma membrane, extracellular region

Inferred from: [Laminin-511 degradation by MMP14 \(Homo sapiens\)](#)

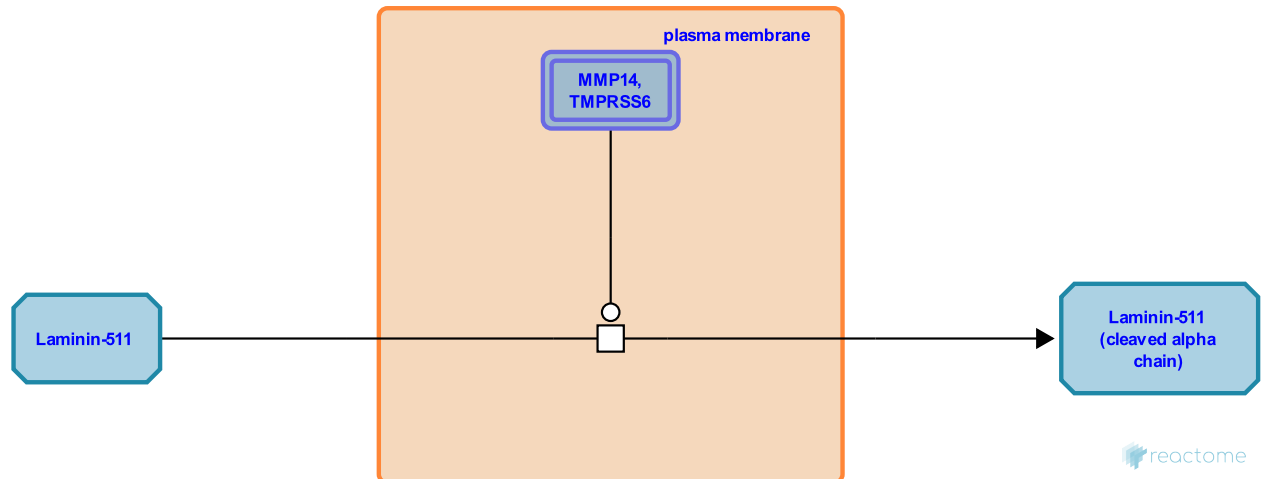

Laminins are an important molecular component of the basement membranes (BMs) in a variety of tissue types. They have a cruciform shape, and are composed of three chains, alpha, beta and gamma., all of which have multiple subtypes. At the ultrastructural level, each laminin trimer appears as a cross-like structure with a large globular domain (LG domain) at the base of the cross. The LG domain is the C-terminal domain of the alpha subunit; it is divided into five homologous subdomains LG1-5 (Sugawara et al. 2008). Laminin-511 (alpha-5 beta-1 gamma-1) is a major structural component of many basement membranes (BMs) including the BM that separates the epidermis from the dermis (Määttä et al. 2001). MMP14 (MT1-MMP) has been shown to cleave the alpha chain of laminin-511, promoting tumor cell migration (Bair et al. 2005). Loss of laminin-511 is a likely contributor to age-related hair loss (Pouliot et al. 2002).

Editions

2012-08-08	Authored	Jupe, S.
2013-08-13	Edited	Jupe, S.
2013-08-13	Reviewed	Ricard-Blum, S.

NID1 degradation by MMP1, 9, 12, ELANE ↗

Location: [Degradation of the extracellular matrix](#)

Stable identifier: R-HSA-1592270

Type: transition

Compartments: extracellular region

Inferred from: [Nid1 degradation by MMP1, 9, 12, ELANE \(Homo sapiens\)](#)

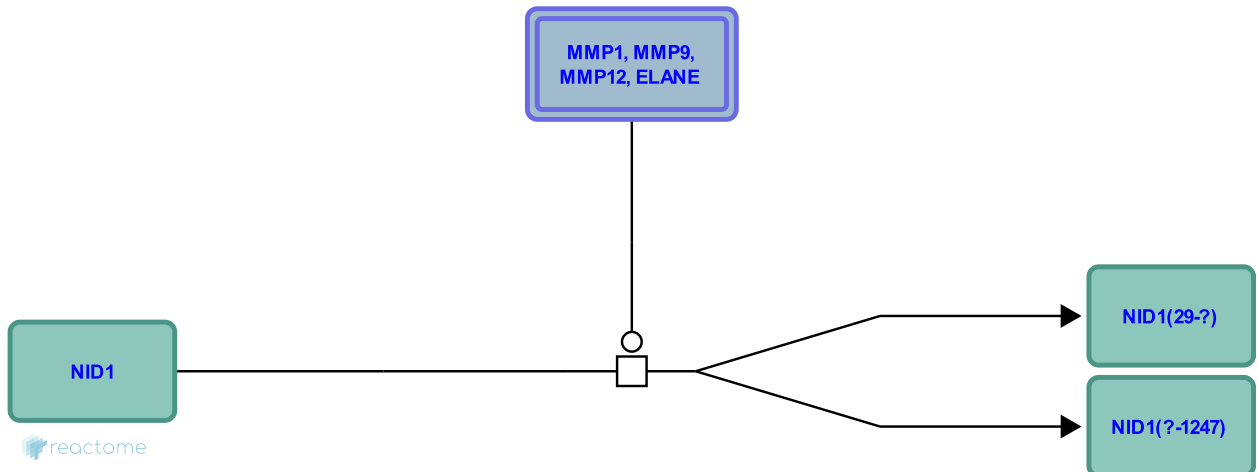

Nidogen-1 (entactin) is a member of the nidogen family of basement membrane glycoproteins. It interacts with several other components of basement membranes, notably it connects the collagen and laminin networks to each other (Yurchenko & Patton 2009). MMPs 3, 7 (Mayer et al. 1993), 1, 9, (Sires et al. 1993), 12 (Gronski et al. 1997), 14, 15 (d'Ortho et al. 1997), 19 (Stracke et al. 2000) and leukocyte elastase (Mayer et al. 1993) can all degrade Nidogen-1.

Editions

2012-08-08	Authored	Jupe, S.
2013-08-13	Edited	Jupe, S.
2013-08-13	Reviewed	Ricard-Blum, S.

NID1 degradation by MMP3, 7 ↗

Location: [Degradation of the extracellular matrix](#)

Stable identifier: R-HSA-2533970

Type: transition

Compartments: extracellular region

Inferred from: [Nid1 degradation by Mmp3, 7 \(Mus musculus\)](#)

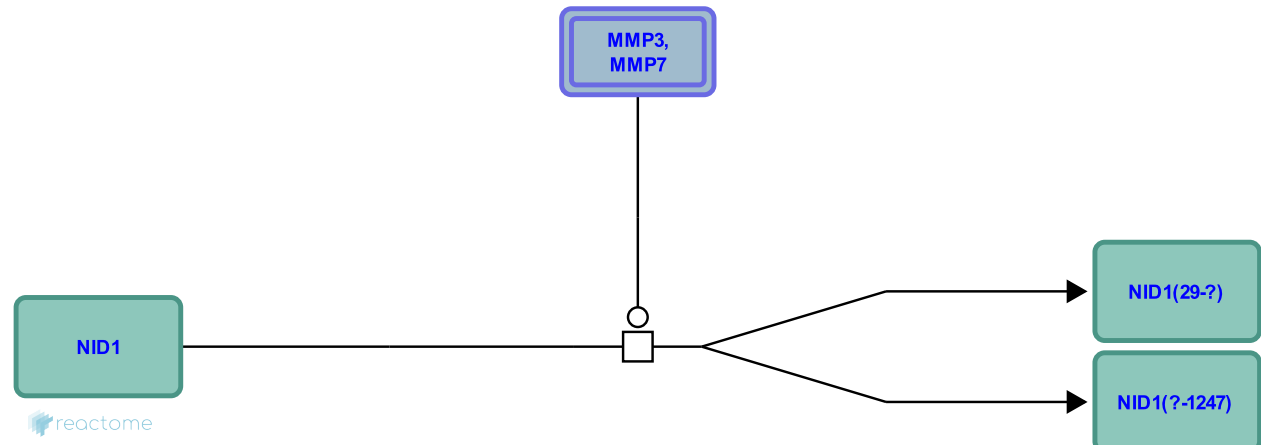

Nidogen-1 (entactin) is a member of the nidogen family of basement membrane glycoproteins. It interacts with several other components of basement membranes, notably it connects the collagen and laminin networks to each other (Yurchenko & Patton 2009). MMPs 3, 7 (Mayer et al. 1993), 1, 9, (Sires et al. 1993), 12 (Gronski et al. 1997), 14, 15 (d'Ortho et al. 1997), 19 (Stracke et al. 2000) and leukocyte elastase (Mayer et al. 1993) can all degrade Nidogen-1.

Editions

2012-08-08	Authored	Jupe, S.
2013-08-13	Edited	Jupe, S.
2013-08-13	Reviewed	Ricard-Blum, S.

NID1 degradation by MMP14, MMP15 ↗

Location: [Degradation of the extracellular matrix](#)

Stable identifier: R-HSA-2533965

Type: transition

Compartments: plasma membrane, extracellular region

Inferred from: [Nid1 degradation by MMP14, MMP15 \(Homo sapiens\)](#)

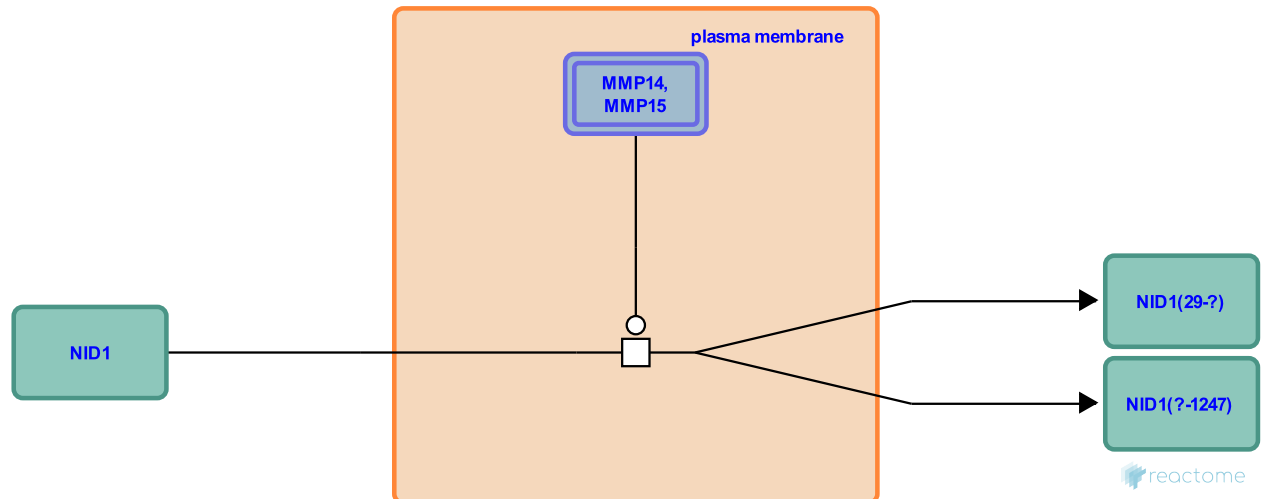

Nidogen-1 (entactin) is a member of the nidogen family of basement membrane glycoproteins. It interacts with several other components of basement membranes, notably it connects the collagen and laminin networks to each other (Yurchenko & Patton 2009). MMPs 3, 7 (Mayer et al. 1993), 1, 9, (Sires et al. 1993), 12 (Gronski et al. 1997), 14, 15 (d'Ortho et al. 1997), 19 (Stracke et al. 2000) and leukocyte elastase (Mayer et al. 1993) can all degrade Nidogen-1.

Editions

2012-08-08	Authored	Jupe, S.
2013-08-13	Edited	Jupe, S.
2013-08-13	Reviewed	Ricard-Blum, S.

NID1 degradation by MMP19 ↗

Location: [Degradation of the extracellular matrix](#)

Stable identifier: R-HSA-3791319

Type: transition

Compartments: extracellular region

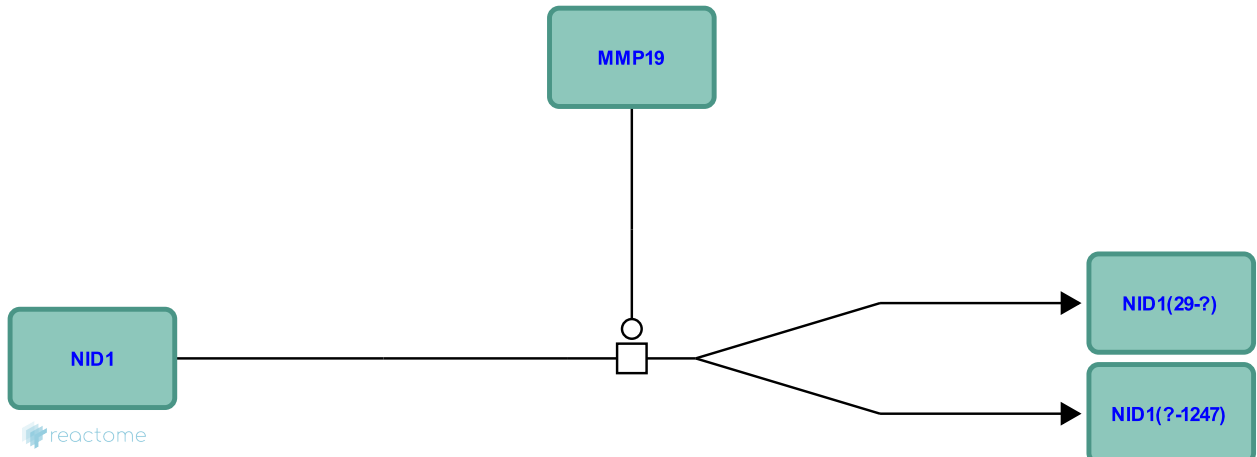

Nidogen-1 (entactin) is a member of the nidogen family of basement membrane glycoproteins. It interacts with several other components of basement membranes, notably it connects the collagen and laminin networks to each other (Yurchenko & Patton 2009). MMPs 3, 7 (Mayer et al. 1993), 1, 9, (Sires et al. 1993), 12 (Gronski et al. 1997), 14, 15 (d'Ortho et al. 1997), 19 (Stracke et al. 2000) and leukocyte elastase (Mayer et al. 1993) can all degrade Nidogen-1.

Literature references

Murphy, G., Knäuper, V., López-Otin, C., Stracke, JO., Hutton, M., Stewart, M. et al. (2000). Biochemical characterization of the catalytic domain of human matrix metalloproteinase 19. Evidence for a role as a potent basement membrane degrading enzyme. *J. Biol. Chem.*, 275, 14809-16. ↗

Editions

2012-08-08	Authored	Jupe, S.
2013-08-13	Edited	Jupe, S.
2013-08-13	Reviewed	Ricard-Blum, S.

Aggrecan degradation by ADAMTSs ↗

Location: [Degradation of the extracellular matrix](#)

Stable identifier: R-HSA-1592310

Type: transition

Compartments: extracellular region

Inferred from: [Aggrecan degradation by ADAMTS4,ADAMTS5 \(Bos taurus\)](#)

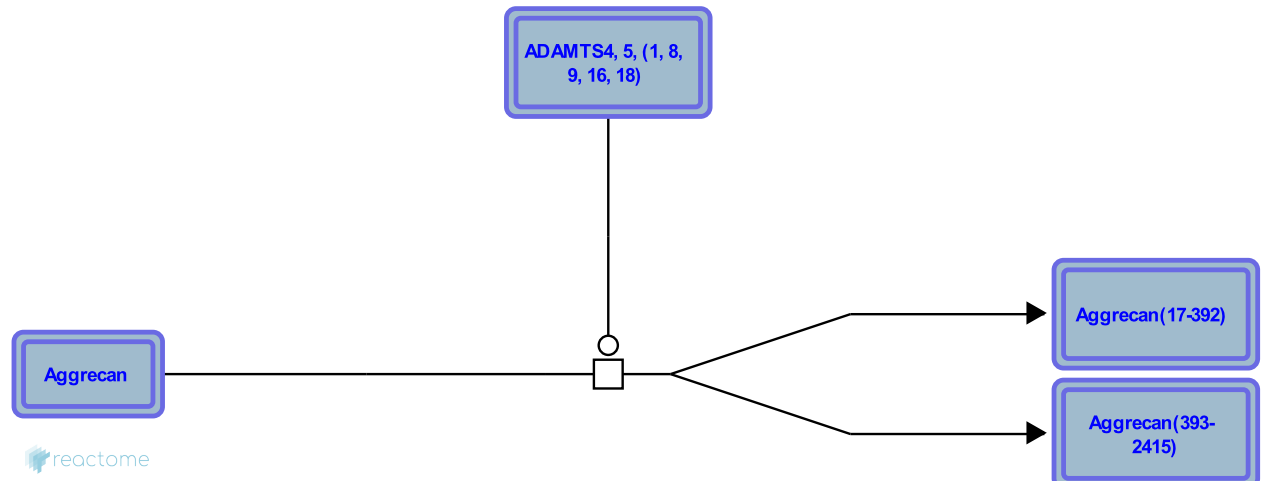

Aggrecan (large aggregating proteoglycan, chondroitin sulfate proteoglycan 1) is a major structural component of cartilage, particularly articular cartilage. The core protein has over 100 chains of chondroitin sulphate and keratan sulphate giving a MWt of about 250 kDa. The core protein has 2 N-terminal globular domains G1 and G2 and a C-terminal globular G3 domain. G2 and G3 are separated by a region heavily modified with negatively charged glycosaminoglycans (GAGs). The two main modifier moieties keratan sulfate (KS) and chondroitin sulfate (CS) are arranged into two CS regions and a KS-rich region. The 15-kDa interglobular linker (IGD) between the N-terminal G1 and G2 domains is particularly susceptible to proteolysis (Caterson et al. 2000). Degradation in this region is associated with the development of osteoarthritis (Troeberg & Nagase 2012). Members of the ADAM (A Disintegrin And Metalloprotease) protein family are responsible for this cleavage (East et al. 2007, Huang & Wu 2008).

Matrix metalloproteinase (MMP) 3 was the first protease found to degrade aggrecan. It preferentially cleaves the Asn341~Phe342 bond (Fosang et al. 1991). MMP2, 7, 9 (Fosang et al. 1992), 1, 8 (Fosang et al. 1993), 13 (Fosang et al. 1996) and 12 (Durigova et al. 2011) were all found to be able to cleave this site as well as others towards the C-terminus. However, the majority of aggrecan fragments present in synovial fluid of OA patients are cleaved at Glu392-Ala373 (numbered here according to the UniProt sequence, these residues referred to as Glu373-Ala374 in most literature) in the IGD (Sandy et al. 1992). ADAMTS5 (aggrecanase-2, Abbaszade et al. 1999) and to a lesser extent ADAMTS4 (aggrecanase-1, Tortorella et al. 1999) are primarily responsible (Gendron et al. 2007) though the preferred cleavage sites of these are in the CS-2 domain. ADAMTS1 (Kuno et al. 2000, Rodriques-Manzaneque et al. 2002), 9, (Somerville et al. 2003), 8 (Colins-Racie 2004), 16 and 18 (Zeng et al. 2006) can also degrade aggrecan in vitro.

Editions

2012-08-08	Authored	Jupe, S.
2013-08-13	Edited	Jupe, S.
2013-08-13	Reviewed	Ricard-Blum, S.

Aggrecan degradation by MMP1,2,3,7,9,12,13 ↗

Location: [Degradation of the extracellular matrix](#)

Stable identifier: R-HSA-3791295

Type: transition

Compartments: extracellular region

Inferred from: [Aggrecan degradation by MMP1,2,3,7,9,12,13 \(Homo sapiens\)](#)

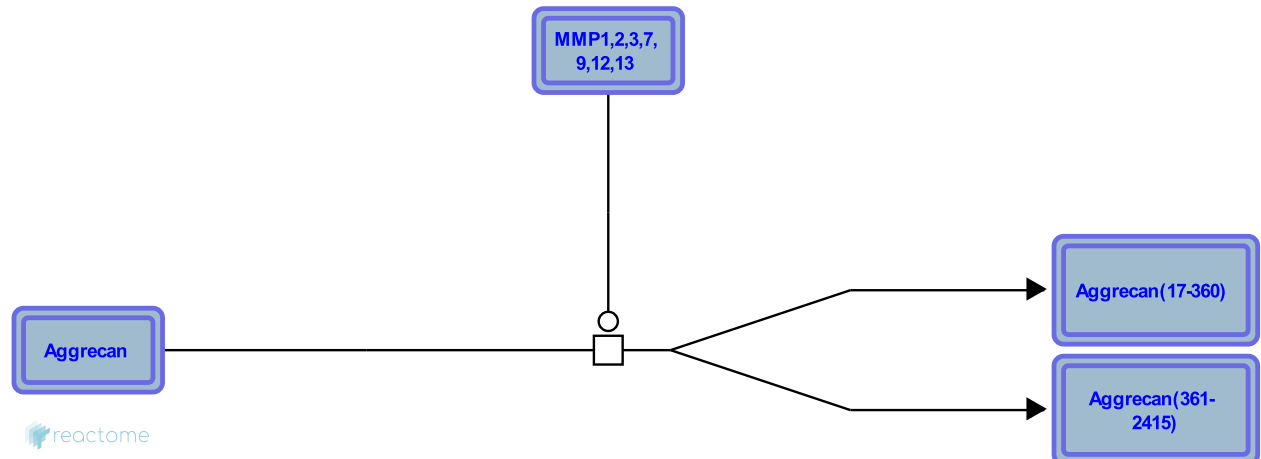

Aggrecan (large aggregating proteoglycan, chondroitin sulfate proteoglycan 1) is a major structural component of cartilage, particularly articular cartilage. The core protein has over 100 chains of chondroitin sulphate and keratan sulphate giving a MWt of about 250 kDa. The core protein has 2 N-terminal globular domains G1 and G2 and a C-terminal globular G3 domain. G2 and G3 are separated by a region heavily modified with negatively charged glycosaminoglycans (GAGs). The two main modifier moieties keratan sulfate (KS) and chondroitin sulfate (CS) are arranged into two CS regions and a KS-rich region. The 15-kDa interglobular linker (IGD) between the N-terminal G1 and G2 domains is particularly susceptible to proteolysis (Caterson et al. 2000). Degradation in this region is associated with the development of osteoarthritis (Troeberg & Nagase 2012). Members of the ADAM (A Disintegrin And Metalloprotease) protein family are believed to be largely responsible for this cleavage (East et al. 2007, Huang & Wu 2008). The majority of aggrecan fragments present in synovial fluid of OA patients are cleaved at Glu392-Ala393 (numbering used here refers to the UniProt sequence, these residues often designated Glu373-Ala374 in literature) in the IGD (Sandy et al. 1992).

Matrix metalloproteinase (MMP) 3 was the first protease found to degrade aggrecan. It preferentially cleaves the Asn360-Phe361 bond (numbering used here refers to the UniProt sequence, these residues often designated Asn341-Phe342 in literature). (Fosang et al. 1991). MMP2, 7, 9 (Fosang et al. 1992), 1, 8 (Fosang et al. 1993), 13 (Fosang et al. 1996) and 12 (Durigova et al. 2011) were all found to be able to cleave this site as well as other sites towards the C-terminus.

Editions

2012-08-08	Authored	Jupe, S.
2013-08-13	Edited	Jupe, S.
2013-08-13	Reviewed	Ricard-Blum, S.

HTRA1 hydrolyzes ACAN (Aggrecan) ↗

Location: [Degradation of the extracellular matrix](#)

Stable identifier: R-HSA-8855825

Type: transition

Compartments: extracellular region

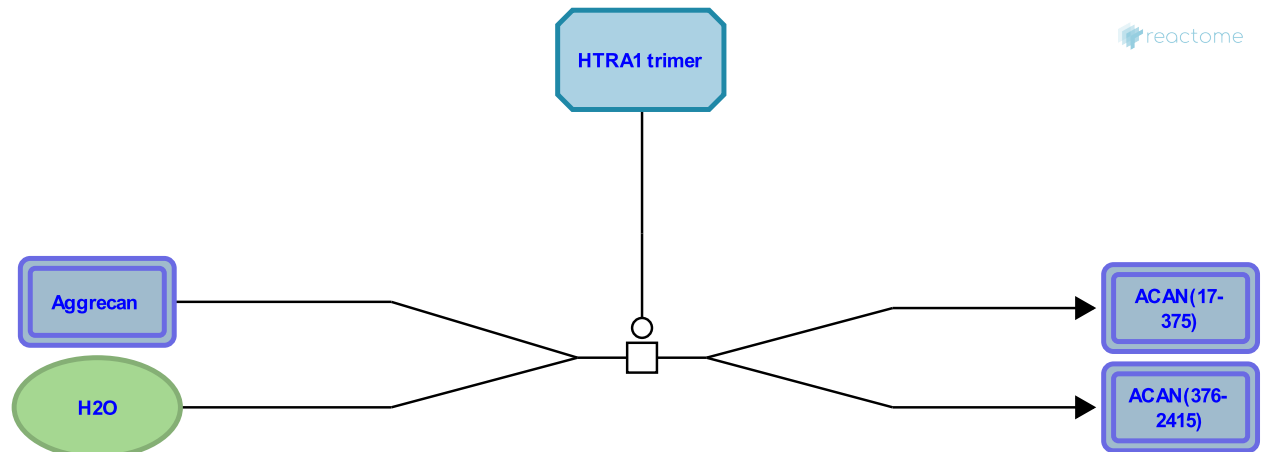

Extracellular HTRA1 (High-temperature requirement A serine peptidase 1) catalyzes the hydrolysis of a specific peptide bond in ACAN (Aggrecan) (Chamberland et al. 2009; Hu et al. 1998). The enzyme is a homotrimer (Truebestein et al. 2011). HTRA1 is thereby implicated in the degradation of extracellular matrix. Indirect studies in mouse model systems (e.g., Oka et al. 2004) that HTRA1 may modulate the activity of Tgf-beta and thereby play additional roles, not annotated here, in the turnover of extracellular matrix both normally and during inflammation.

Literature references

- Tennstaedt, A., Clausen, T., Mönig, T., Truebestein, L., Krojer, T., Kaiser, M. et al. (2011). Substrate-induced remodeling of the active site regulates human HTRA1 activity. *Nat. Struct. Mol. Biol.*, 18, 386-8. ↗
- Matsumoto, M., Ueta, Y., Kanda, H., Kajikawa, M., Kawaichi, M., Oka, C. et al. (2004). HtrA1 serine protease inhibits signaling mediated by Tgfbeta family proteins. *Development*, 131, 1041-53. ↗
- Hu, SI., Klein, M., Nantermet, P., Carozza, M., Luk, D., Crowl, RM. (1998). Human HtrA, an evolutionarily conserved serine protease identified as a differentially expressed gene product in osteoarthritic cartilage. *J. Biol. Chem.*, 273, 34406-12. ↗
- Morris, EA., LaVallie, ER., Liu, L., Wang, E., Collins-Racie, LA., Jones, AR. et al. (2009). Identification of a novel HtrA1-susceptible cleavage site in human aggrecan: evidence for the involvement of HtrA1 in aggrecan proteolysis in vivo. *J. Biol. Chem.*, 284, 27352-9. ↗

Editions

2016-02-06	Authored, Edited	D'Eustachio, P.
2016-02-08	Reviewed	Jupe, S.

Brevican degradation by ADAMTS4, ADAMTS5 ↗

Location: [Degradation of the extracellular matrix](#)

Stable identifier: R-HSA-3788075

Type: transition

Compartments: extracellular region

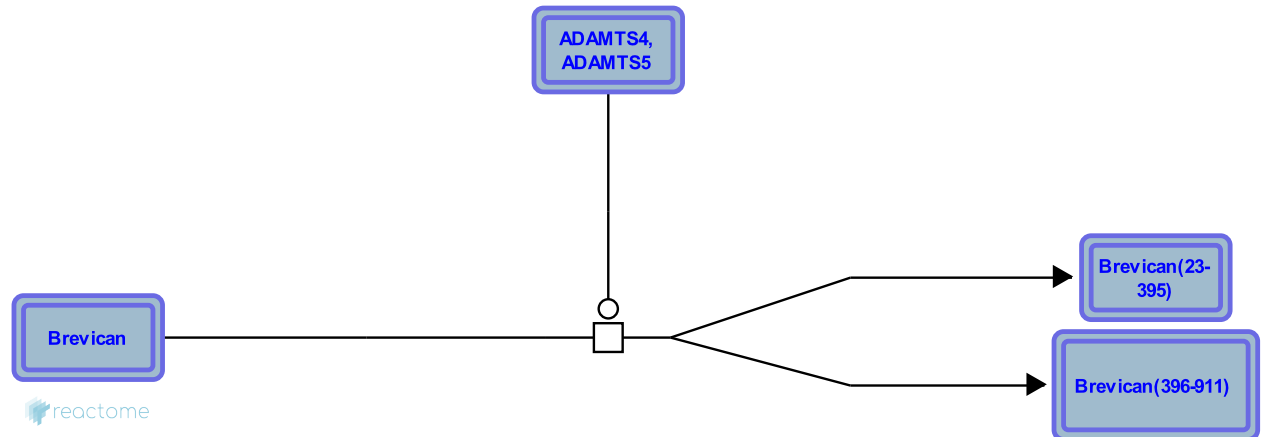

Brevican, a member of the lectican family, is one of the most abundant proteoglycans in normal adult brain tissues. It is thought to form lattice structures by linking hyaluronan and tenascin-R through its N- and C-terminal globular domains, respectively. As brain extracellular matrix (ECM) contains no collagen fibrils, this matrix of hyaluronan/brevican/tenascin-R is considered essential to maintain the integrity of brain ECM. Degradation of brevican by proteinases disrupts ECM structures and facilitates invasion of glioma cells (Yamaguchi 2000). The major brevican cleavage site observed under physiological conditions (Yamada et al. 1994) and during glioma invasion (Zhang et al. 1998) is the Glu395-Ser396 bond present within the central domain of the core protein, forming an ~50-kDa N-terminal fragment. This bond is cleaved by ADAMTS4 and 5 (Nakamura et al. 2000, Matthews et al. 2000, Nakada et al. 2005). Matrix metalloproteinases that digest brevican preferentially cleave the Ala360-Phe361 bond. (Nakamura et al. 2000, Nakada et al. 2005, Lettau et al. 2010).

Literature references

Kita, D., Yamaguchi, Y., Miura, R., Yamashita, J., Takahashi, T., Miyamori, H. et al. (2005). Human glioblastomas overexpress ADAMTS-5 that degrades brevican. *Acta Neuropathol.*, 110, 239-46. ↗

Miura, R., Sugimoto, K., Inoki, I., Fujii, Y., Okada, Y., Tanzawa, K. et al. (2000). Brevican is degraded by matrix metalloproteinases and aggrecanase-1 (ADAMTS4) at different sites. *J. Biol. Chem.*, 275, 38885-90. ↗

Editions

2012-08-08	Authored	Jupe, S.
2013-08-13	Edited	Jupe, S.
2013-08-13	Reviewed	Ricard-Blum, S.

Brevican degradation by MMP1, 2, 3, 7,8,10,13,19 ↗

Location: [Degradation of the extracellular matrix](#)

Stable identifier: R-HSA-3791149

Type: transition

Compartments: extracellular region

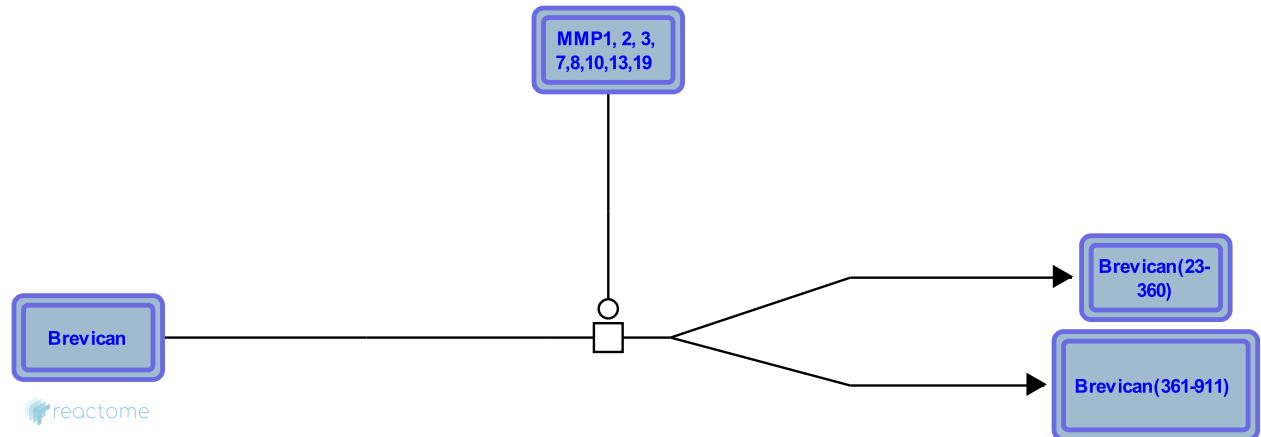

Brevican, a member of the lectican family, is one of the most abundant proteoglycans in normal adult brain tissues. It is thought to form lattice structures by linking hyaluronan and tenascin-R through its N- and C-terminal globular domains, respectively. As brain extracellular matrix (ECM) contains no collagen fibrils, this matrix of hyaluronan/brevican/tenascin-R is considered essential to maintain the integrity of brain ECM. Degradation of brevican by proteinases disrupts ECM structures and facilitates invasion of glioma cells (Yamaguchi 2000). The major brevican cleavage site observed under physiological conditions (Yamada et al. 1994) and during glioma invasion (Zhang et al. 1998) is the Glu395-Ser396 bond present within the central domain of the core protein, forming an ~50-kDa N-terminal fragment. This bond is cleaved by ADAMTS4 and 5 (Nakamura et al. 2000, Matthews et al. 2000, Nakada et al. 2005). Matrix metalloproteinases that digest brevican (MMP-1, -2, -3, -7, -8, -10, -13 and -19) preferentially cleave the Ala360-Phe361 bond. (Nakamura et al. 2000, Nakada et al. 2005, Lettau et al. 2010).

Literature references

Brauer, R., Mentlein, R., Hattermann, K., Held-Feindt, J., Sedlacek, R., Lettau, I. (2010). Matrix metalloproteinase-19 is highly expressed in astroglial tumors and promotes invasion of glioma cells. *J. Neuropathol. Exp. Neurol.*, 69, 215-23. ↗

Miura, R., Sugimoto, K., Inoki, I., Fujii, Y., Okada, Y., Tanzawa, K. et al. (2000). Brevican is degraded by matrix metalloproteinases and aggrecanase-1 (ADAMTS4) at different sites. *J. Biol. Chem.*, 275, 38885-90. ↗

Editions

2012-08-08	Authored	Jupe, S.
2013-08-13	Edited	Jupe, S.
2013-08-13	Reviewed	Ricard-Blum, S.

HSPG2 (perlecan) degradation by MMP3, plasmin, (MMP12) ↗

Location: [Degradation of the extracellular matrix](#)

Stable identifier: R-HSA-1592314

Type: transition

Compartments: extracellular region

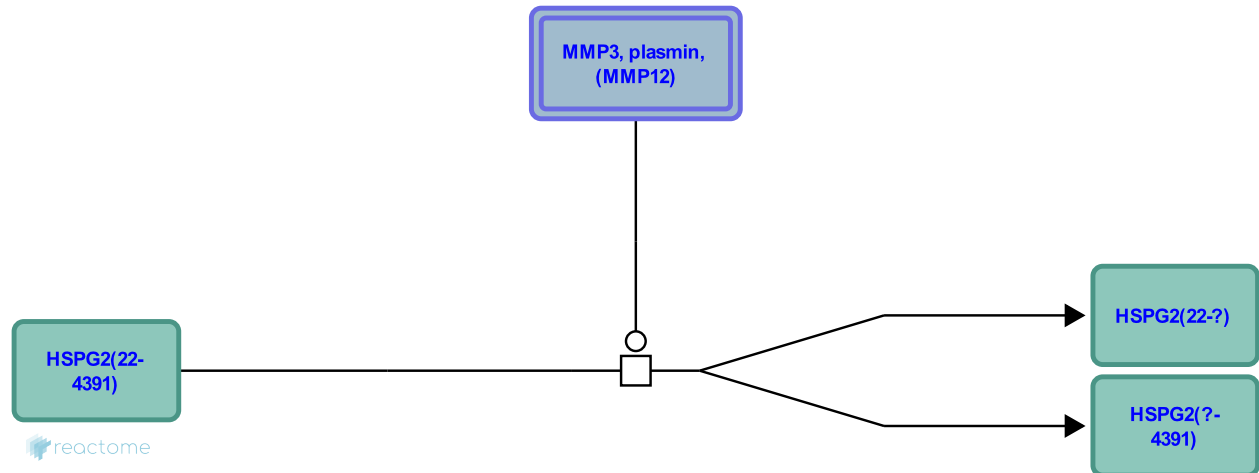

HSPG2 protein (perlecan) consists of a core protein of molecular weight 470 kDa with three long glycosaminoglycan (GAG) chains attached, each approximately 70-100 kDa. These are usually heparan sulphate (HS), but can be chondroitin sulphate (CS). The core protein consists of five distinct structural domains. The N-terminal domain I (aa ~1-195) contains attachment sites for GAG chains. Although GAG chains are not required for correct folding and secretion of the protein, lack of GAG or decreased sulfation can decrease perlecan's ability to interact with matrix proteins. Removal of GAG chains may affect matrix organization and endothelial barrier function. The GAG chains of HSPG2 bind growth factors in the ECM, and serve as co-ligands or ligand enhancers when bound to receptors. For example, HS-bound FGF was released from cultured cells by treatments with MMP3, rat MMP13, and plasmin (Whitelock et al. 1996). Other MMPs reported to degrade HSPG2 include MMP14 and MMP15 (d'Ortho et al. 1997). MMP12 releases chondroitin sulphate and heparan sulphate from basement membranes (Gronski et al. 1997) and degrades the related aggrecan (Durigova et al. 2011) so may degrade perlecan. Corneal epithelium explant growth correlates with MMP2 expression, an initial degradation of the original basement membrane, and an initial upregulation followed by downregulation of MMP9. However this may not result from direct cleavage of HSPG2 by these MMPs, they may modulate some factor involved in the maturation of basement membrane (Li et al. 2006). The core protein of HSPG2 can be cleaved by cathepsin S (Liuzzo et al. 1999).

Literature references

Underwood, PA., Murdoch, AD., Whitelock, JM., Iozzo, RV. (1996). The degradation of human endothelial cell-derived perlecan and release of bound basic fibroblast growth factor by stromelysin, collagenase, plasmin, and heparanases. *J Biol Chem*, 271, 10079-86. ↗

Editions

2012-08-08	Authored	Jupe, S.
2013-08-13	Edited	Jupe, S.
2013-08-13	Reviewed	Ricard-Blum, S.

HSPG2 (perlecan) degradation by MMP13, CTSS ↗

Location: [Degradation of the extracellular matrix](#)

Stable identifier: R-HSA-2534160

Type: transition

Compartments: extracellular region

Inferred from: [Degradation of HSPG2 by Mmp13 and Ctss \(Homo sapiens\)](#)

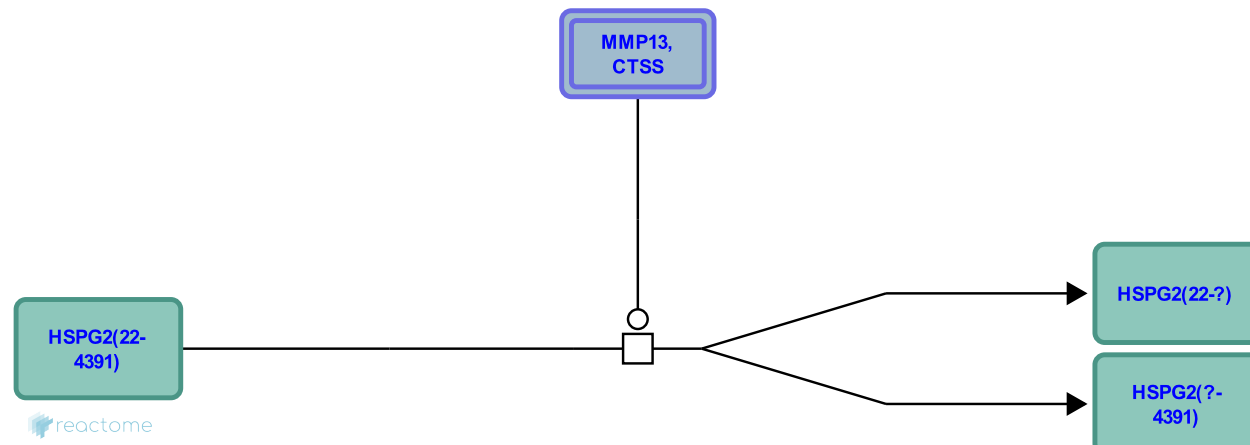

The GAG chains of HSPG2 bind growth factors in the ECM, and serve as co-ligands or ligand enhancers when bound to receptors. For example, HS-bound FGF was released from cultured cells by treatments with MMP3, rat MMP13, and plasmin (Whitelock et al. 1996). The core protein of HSPG2 can be cleaved by cathepsin S (Liuzzo et al. 1999).

Editions

2012-08-08	Authored	Jupe, S.
2013-08-13	Edited	Jupe, S.
2013-08-13	Reviewed	Ricard-Blum, S.

HSPG2 (perlecan) degradation by MMP14, MMP15 ↗

Location: [Degradation of the extracellular matrix](#)

Stable identifier: R-HSA-2534240

Type: transition

Compartments: plasma membrane, extracellular region

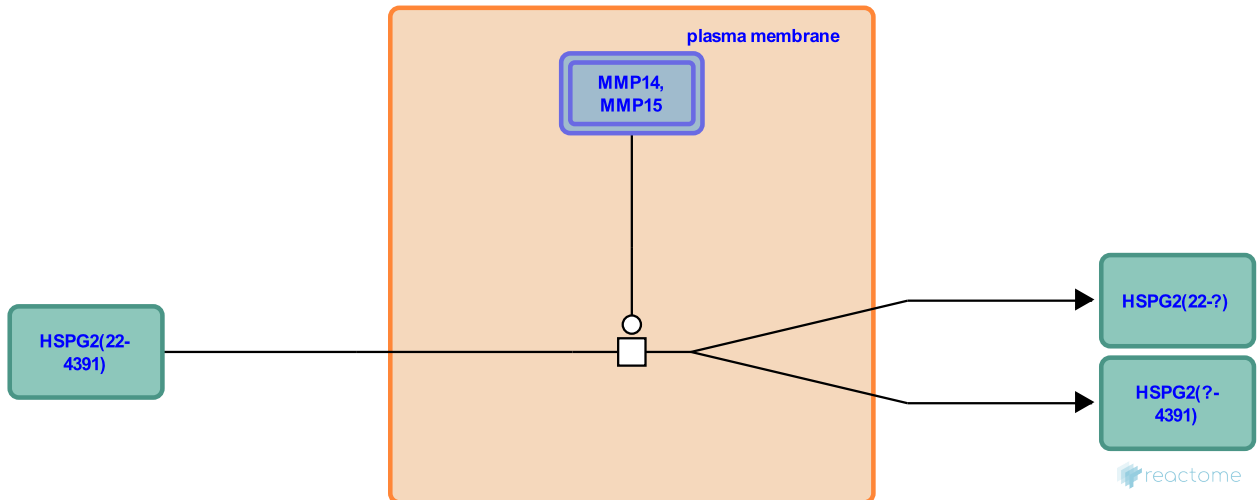

HSPG2 protein (perlecan) consists of a core protein of molecular weight 470 kDa with three long glycosaminoglycan (GAG) chains attached, each approximately 70-100 kDa. The GAG chains of HSPG2 bind growth factors in the ECM, and serve as co-ligands or ligand enhancers when bound to receptors. MMP14 and MMP15 (MT1-MMP and MT2-MMP) can degrade HSPG2 (d'Ortho et al. 1997).

Literature references

Gavrilovic, J., Messent, A., Smith, B., Butler, G., Zardi, L., d'Ortho, MP. et al. (1997). Membrane-type matrix metalloproteinases 1 and 2 exhibit broad-spectrum proteolytic capacities comparable to many matrix metalloproteinases. *Eur J Biochem*, 250, 751-7. ↗

Editions

2012-08-08	Authored	Jupe, S.
2013-08-13	Edited	Jupe, S.
2013-08-13	Reviewed	Ricard-Blum, S.

HSPG2 (perlecan) is cleaved by BMP1, TLL1, TLL2, Cathepsin L1 ↗

Location: [Degradation of the extracellular matrix](#)

Stable identifier: R-HSA-3814820

Type: transition

Compartments: extracellular region

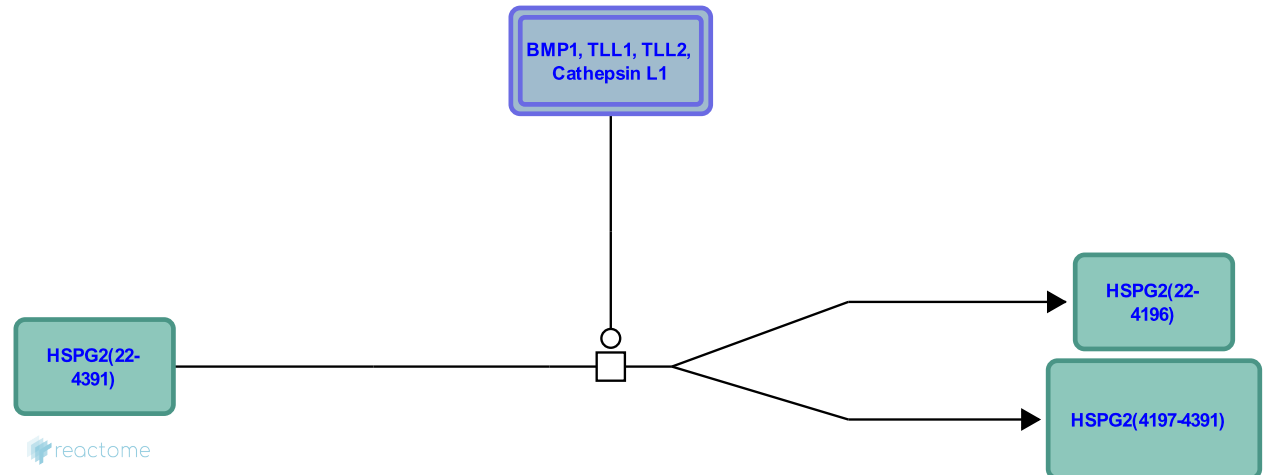

Endorepellin is the 85-kDa C-terminal domain V of HSPG2 (perlecan). It consists of a series of laminin-like globular (LG) domains interconnected by short epidermal growth factor-like repeats (Hohenester & Engel 2002). Endorepellin has angiostatic activity (Mongiat et al. 2003) which is primarily localised in the LG3 domain (Bix et al. 2004). Bone morphogenetic protein 1 (BMP1), its isoform mammalian Tolloid (mTLD), mammalian Tolloid-like-1 and -2 (TLL1, TLL2) (Gonzalez et al. 2005) and cathepsin-L1 (Cailhier et al. 2008) can liberate LG3 by cleaving endorepellin between Asn4196 and Asp4197.

Literature references

Cailhier, JF., Iozzo, RV., Raymond, MA., Pshezhetsky, AV., Hébert, MJ., Laplante, P. et al. (2008). Caspase-3 activation triggers extracellular cathepsin L release and endorepellin proteolysis. *J. Biol. Chem.*, 283, 27220-9. ↗

Zhang, Y., Iozzo, RV., Bix, G., Fu, J., Gonzalez, EM., Greenspan, DS. et al. (2005). BMP-1/Tolloid-like metalloproteases process endorepellin, the angiostatic C-terminal fragment of perlecan. *J. Biol. Chem.*, 280, 7080-7. ↗

Editions

2012-08-08	Authored	Jupe, S.
2013-08-13	Edited	Jupe, S.
2013-08-13	Reviewed	Ricard-Blum, S.

DCN (decorin) degradation by MMP2, MMP3, MMP7 ↗

Location: [Degradation of the extracellular matrix](#)

Stable identifier: R-HSA-2534248

Type: transition

Compartments: extracellular region

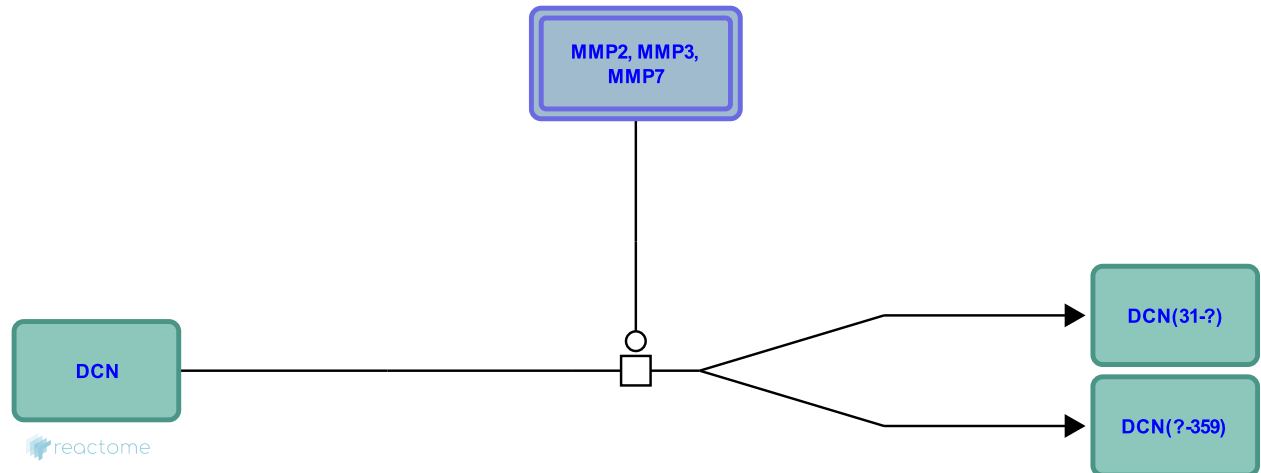

DCN consists of a core protein of ?40 kDa attached to a single chondroitin or dermatan sulfate glycosaminoglycan (GAG) chain. It interacts with collagen types I, II (Vogel et al. 1984), III (Witos et al. 2011), VI (Bidanset et al. 1992) and XIV (Ehnis et al. 1997). DCN acts as a sink for all three isoforms of TGF-Beta, binding them while already bound to collagen (Markmann et al. 2000). Degradation of DCN by matrix metalloproteinases MMP2, 3 or 7 results in the release of TGF-beta (Imai et al. 1997). In addition, DCN binds to EGFR (Iozzo et al. 1999) causing prolonged down-regulation of EGFR-mediated mobilization of intracellular calcium (Csordás et al. 2000).

Literature references

Hiramatsu, A., Okada, Y., Imai, K., Pierschbacher, MD., Fukushima, D. (1997). Degradation of decorin by matrix metalloproteinases: identification of the cleavage sites, kinetic analyses and transforming growth factor-beta1 release. *Biochem. J.*, 322, 809-14. ↗

Editions

2012-08-08	Authored	Jupe, S.
2013-08-13	Edited	Jupe, S.
2013-08-13	Reviewed	Ricard-Blum, S.

DCN (decorin) degradation by MMP14 [↗](#)

Location: [Degradation of the extracellular matrix](#)

Stable identifier: R-HSA-3828025

Type: transition

Compartments: plasma membrane, extracellular region

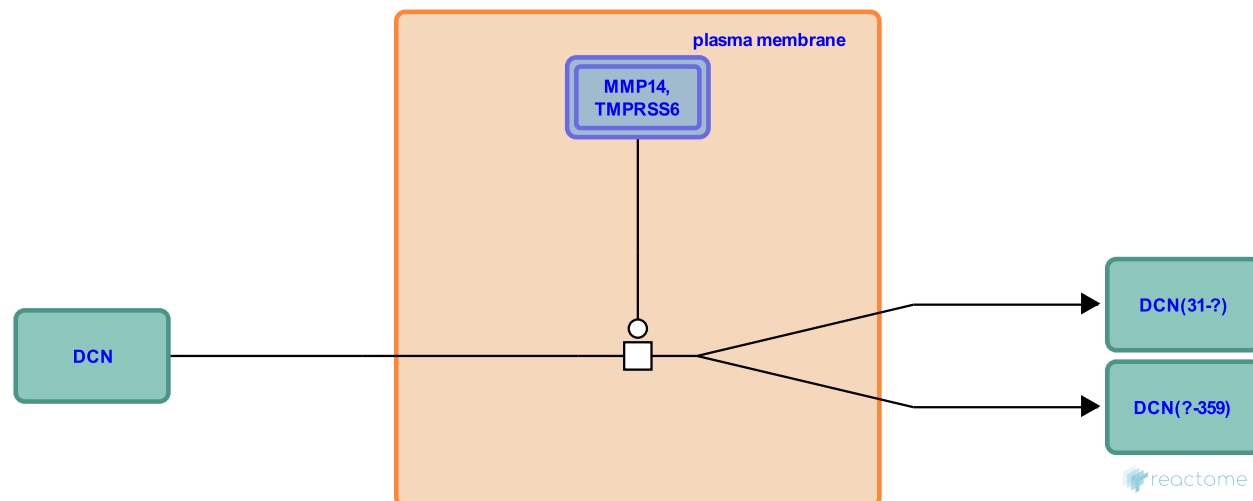

MMP14 (MT1-MMP) is able to degrade decorin in keratocytes during bFGF-induced corneal neovascularization.

Literature references

Chang, JH., Mimura, T., Zhou, Z., Onguchi, T., Kojima, T., Kim, TI. et al. (2009). MT1-MMP-mediated cleavage of decorin in corneal angiogenesis. *J. Vasc. Res.*, 46, 541-50. [↗](#)

Editions

2012-08-08	Authored	Jupe, S.
2013-08-13	Edited	Jupe, S.
2013-08-13	Reviewed	Ricard-Blum, S.

E-cadherin degradation by MMP3, MMP7 and plasmin. ↗

Location: [Degradation of the extracellular matrix](#)

Stable identifier: R-HSA-1454843

Type: transition

Compartments: plasma membrane, extracellular region

Inferred from: [E-cadherin strand dimer degradation by MMP3, MMP7 and Plasmin \(Homo sapiens\)](#)

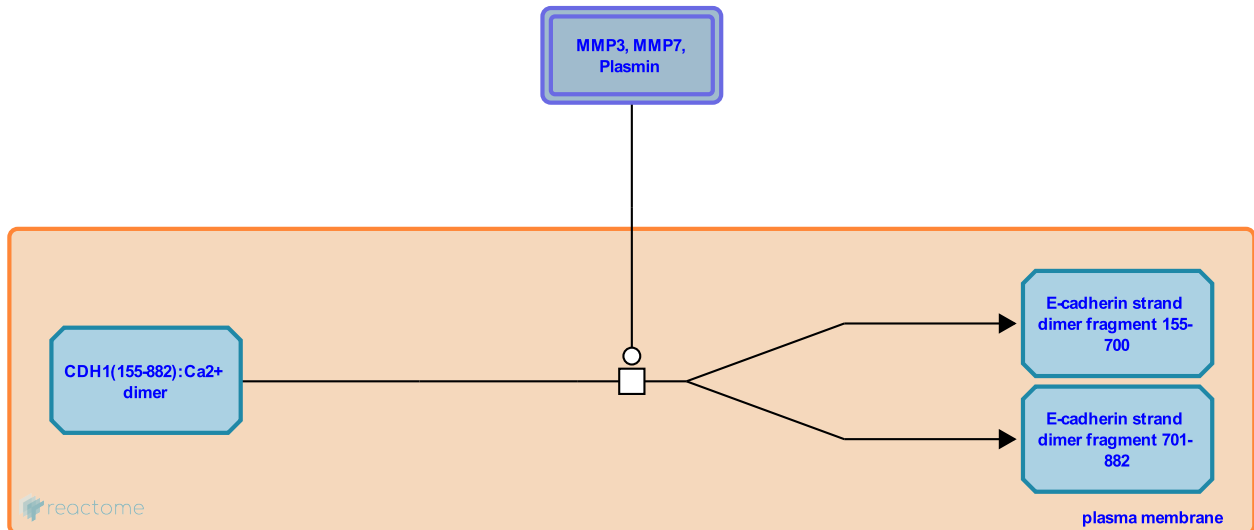

E-cadherin (CDH1) localizes to the lateral membrane of differentiated epithelia, providing the structural foundation for adherens junctions, multiprotein complexes that link cell-cell contacts to the actin cytoskeleton and various signaling molecules (Perez-Moreno et al. 2003, Baum & Georgiou 2011). The extracellular domain has five cadherin-type repeat ectodomain (EC) modules; the most membrane-distal EC mediates binding with CDH1 on adjacent cells (Boggon et al. 2002). Calcium ions bind between the EC domains of two CDH1 peptides to form a dimer with a rod-like conformation (Boggon et al. 2002) which is required for cell-cell interaction (Gumbiner 1996, Patel et al. 2006). The cytoplasmic tail of E-cadherin binds to the armadillo repeat protein beta-catenin, a target of the Wnt signaling pathway and a cofactor for TCF/LEF-mediated transcription (Gavard & Mège 2005). Beta-catenin in turn binds alpha-catenin, which interacts with the actin microfilament network, actin and the actin-binding proteins vinculin, formins, alpha-actinin, zonula occludin protein, and afadin (Bershadsky 2004). Cell-cell adhesions also contain desmosomes, which link cell contacts to intermediate filaments, and nectin-based, calcium-independent adhesions, which are linked to actin (Takai & Nakanishi 2003, Yin and Green 2004). The critical importance of E-cadherin to normal development and tissue function is demonstrated by embryonic lethal E-cadherin gene mouse knockouts (Larue et al. 1994). Loss of cadherin-based cell-cell adhesion is a hallmark of carcinogenesis, correlating with tumour progression, allowing cells to escape normal growth control signals, resulting in loss of differentiation and increased cell proliferation associated with invasive behaviour (Frixen et al. 1991, Capaldo & Macara 2007). Full-length 120-kDa CDH1 protein is cleaved in the ectodomain close to the plasma membrane by a number of metalloproteases, generating an extracellular 38-kDa C-terminal fragment (CTF) termed CTF1 which can be further processed by a gamma-secretase-like activity to a soluble 33-kDa CTF2 (Marambaud et al. 2002, Roy & Berx 2008). MMP3, MMP7 (Noë et al. 2001, canine MMPs), MMP9 (Symowicz et al. 2007), plasmin (Ryniers et al. 2002, canine plasmin), Kallikrein 7 (Johnson et al. 2007), ADAM10 (Maretzky et al. 2005) and ADAM15 (Najy et al. 2008) all cleave CDH1 extracellularly, close to the transmembrane region. Presenilin-1 (Marambaud et al. 2002), the catalytic subunit of gamma-secretase (Herreman et al. 2003, Li et al. 2003), cleaves CDH1 producing a soluble 33-kDa fragment termed CTF2. Other enzymes like caspase-3 (Steinhusen et al. 2001) and calpain-1 (Rios-Doria et al. 2003) cleave E-cadherin in its cytoplasmic part releasing an intracellular 37 kDa C-terminal fragment.

Editions

2012-08-08	Authored	Jupe, S.
2013-08-13	Edited	Jupe, S.
2013-08-13	Reviewed	Ricard-Blum, S.

E-cadherin degradation by MMP9, KLK7 ↗

Location: [Degradation of the extracellular matrix](#)

Stable identifier: R-HSA-3827958

Type: transition

Compartments: plasma membrane

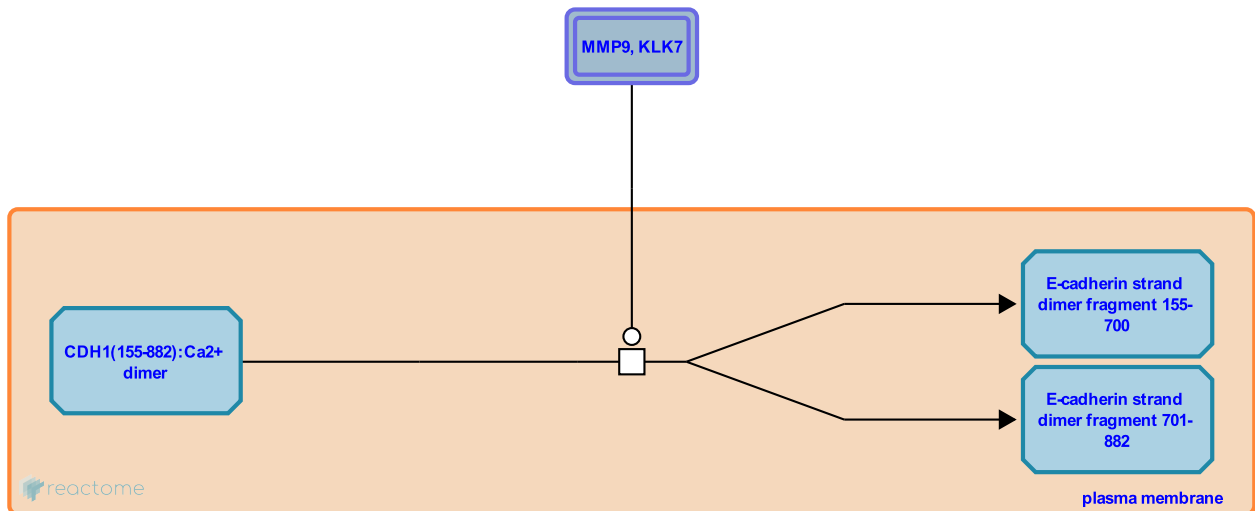

E-cadherin (CDH1) localizes to the lateral membrane of differentiated epithelia, providing the structural foundation for adherens junctions, multiprotein complexes that link cell-cell contacts to the actin cytoskeleton and various signaling molecules (Perez-Moreno et al. 2003, Baum & Georgiou 2011). The extracellular domain has five cadherin-type repeat ectodomain (EC) modules; the most membrane-distal EC mediates binding with CDH1 on adjacent cells (Boggon et al. 2002). Calcium ions bind between the EC domains of two CDH1 peptides to form a dimer with a rod-like conformation (Boggon et al. 2002) which is required for cell-cell interaction (Gumbiner 1996, Patel et al. 2006). The cytoplasmic tail of E-cadherin binds to the armadillo repeat protein beta-catenin, a target of the Wnt signaling pathway and a cofactor for TCF/LEF-mediated transcription (Gavard & Mège 2005). Beta-catenin in turn binds alpha-catenin, which interacts with the actin microfilament network, actin and the actin-binding proteins vinculin, formins, alpha-actinin, zonula occludin protein, and afadin (Bershadsky 2004). Cell-cell adhesions also contain desmosomes, which link cell contacts to intermediate filaments, and nectin-based, calcium-independent adhesions, which are linked to actin (Takai & Nakanishi 2003, Yin and Green 2004). The critical importance of E-cadherin to normal development and tissue function is demonstrated by embryonic lethal E-cadherin gene mouse knockouts (Larue et al. 1994). Loss of cadherin-based cell-cell adhesion is a hallmark of carcinogenesis, correlating with tumour progression, allowing cells to escape normal growth control signals, resulting in loss of differentiation and increased cell proliferation associated with invasive behaviour (Frixen et al. 1991, Capaldo & Macara 2007). Full-length 120-kDa CDH1 protein is cleaved in the ectodomain close to the plasma membrane by a number of metalloproteases, generating an extracellular 38-kDa C-terminal fragment (CTF) termed CTF1 which can be further processed by a gamma-secretase-like activity to a soluble 33-kDa CTF2 (Marambaud et al. 2002, Roy & Berx 2008). MMP3, MMP7 (Noë et al. 2001, canine MMPs), MMP9 (Symowicz et al. 2007), plasmin (Ryniers et al. 2002, canine plasmin), Kallikrein 7 (Johnson et al. 2007), ADAM10 (Maretzky et al. 2005) and ADAM15 (Najy et al. 2008) all cleave CDH1 extracellularly, close to the transmembrane region. Presenilin-1 (Marambaud et al. 2002), the catalytic subunit of gamma-secretase (Herreman et al. 2003, Li et al. 2003), cleaves CDH1 producing a soluble 33-kDa fragment termed CTF2. Other enzymes like caspase-3 (Steinhusen et al. 2001) and calpain-1 (Rios-Doria et al. 2003) cleave E-cadherin in its cytoplasmic part releasing an intracellular 37 kDa c-terminal fragment.

Literature references

- Symowicz, J., Johnson, JJ., Stack, MS., Fishman, DA., Adley, BP., Gleason, KJ. et al. (2007). Engagement of collagen-binding integrins promotes matrix metalloproteinase-9-dependent E-cadherin ectodomain shedding in ovarian carcinoma cells. *Cancer Res.*, 67, 2030-9. ↗
- Ramani, VC., Hennings, L., Haun, RS., Johnson, SK. (2007). Kallikrein 7 enhances pancreatic cancer cell invasion by shedding E-cadherin. *Cancer*, 109, 1811-20. ↗

Editions

2012-08-08	Authored	Jupe, S.
2013-08-13	Edited	Jupe, S.
2013-08-13	Reviewed	Ricard-Blum, S.

E-cadherin degradation by ADAM10, ADAM15 ↗

Location: [Degradation of the extracellular matrix](#)

Stable identifier: R-HSA-4224014

Type: transition

Compartments: plasma membrane

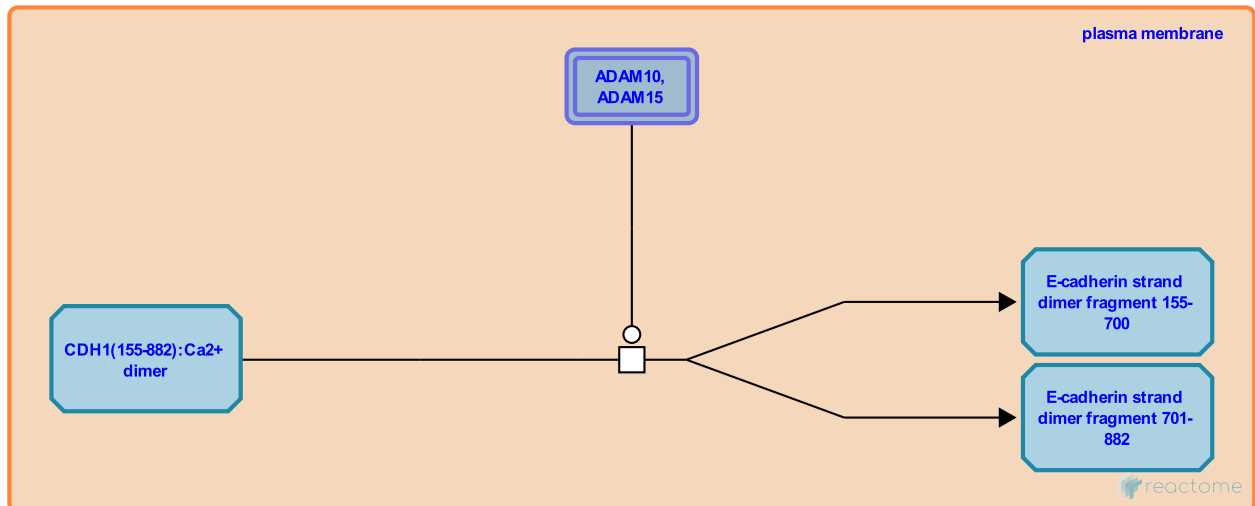

E-cadherin (CDH1) localizes to the lateral membrane of differentiated epithelia, providing the structural foundation for adherens junctions, multiprotein complexes that link cell-cell contacts to the actin cytoskeleton and various signaling molecules (Perez-Moreno et al. 2003, Baum & Georgiou 2011). The extracellular domain has five cadherin-type repeat ectodomain (EC) modules; the most membrane-distal EC mediates binding with CDH1 on adjacent cells (Boggon et al. 2002). Calcium ions cross-link the EC domains of two CDH1 peptides to form a dimer with a rod-like conformation (Boggon et al. 2002) which is required for cell-cell interaction (Gumbiner 1996, Patel et al. 2006). The cytoplasmic tail of E-cadherin binds to the armadillo repeat protein beta-catenin, a target of the Wnt signaling pathway and a cofactor for TCF/LEF-mediated transcription (Gavard & Mège 2005). Beta-catenin in turn binds alpha-catenin, which interacts with the actin microfilament network, actin and the actin-binding proteins vinculin, formins, alpha-actinin, zonula occludin protein, and afadin (Bershadsky 2004). Cell-cell adhesions also contain desmosomes, which link cell contacts to intermediate filaments, and nectin-based, calcium-independent adhesions, which are linked to actin (Takai & Nakanishi 2003, Yin and Green 2004). The critical importance of E-cadherin to normal development and tissue function is demonstrated by embryonic lethal E-cadherin gene mouse knockouts (Larue et al. 1994). Loss of cadherin-based cell-cell adhesion is a hallmark of carcinogenesis, correlating with tumour progression, allowing cells to escape normal growth control signals, resulting in loss of differentiation and increased cell proliferation associated with invasive behaviour (Frixen et al. 1991, Capaldo & Macara 2007).

Full-length 120-kDa CDH1 protein is cleaved in the ectodomain close to the plasma membrane by a number of metalloproteases, generating an extracellular 38-kDa C-terminal fragment (CTF) termed CTF1 which can be further processed by a gamma-secretase-like activity to a soluble 33-kDa CTF2 (Marambaud et al. 2002, Roy & Berx 2008). MMP3, MMP7 (Noë et al. 2001, canine MMPs), MMP9 (Symowicz et al. 2007), plasmin (Ryniers et al. 2002, canine plasmin), Kallikrien 7 (Johnson et al. 2007), ADAM10 (Maretzky et al. 2005) and ADAM15 (Najy et al. 2008) all cleave CDH1 extracellularly, close to the transmembrane region.

Presenilin-1 (Marambaud et al. 2002), the catalytic subunit of gamma-secretase (Herreman et al. 2003, Li et al. 2003), cleaves CDH1 producing a soluble 33-kDa fragment termed CTF2. Other enzymes like caspase-3 (Steinhusen et al. 2001) and calpain-1 (Rios-Doria et al. 2003) cleave E-cadherin in its cytoplasmic part releasing an intracellular 37 kDa c-terminal fragment.

Literature references

- Day, KC., Najy, AJ., Day, ML. (2008). The ectodomain shedding of E-cadherin by ADAM15 supports ErbB receptor activation. *J. Biol. Chem.*, 283, 18393-401. ↗
- Hartmann, D., Proksch, E., Scholz, F., Buchholz, J., Maretzky, T., De Strooper, B. et al. (2005). ADAM10 mediates E-cadherin shedding and regulates epithelial cell-cell adhesion, migration, and beta-catenin translocation. *Proc. Natl. Acad. Sci. U.S.A.*, 102, 9182-7. ↗

Editions

2012-08-08	Authored	Jupe, S.
2013-08-13	Edited	Jupe, S.
2013-08-13	Reviewed	Ricard-Blum, S.

E-cadherin degradation by PS1:NCSTN (Gamma-secretase) ↗

Location: [Degradation of the extracellular matrix](#)

Stable identifier: R-HSA-2534206

Type: transition

Compartments: plasma membrane

Inferred from: [E-cadherin strand dimer degradation by PS1 \(Homo sapiens\)](#)

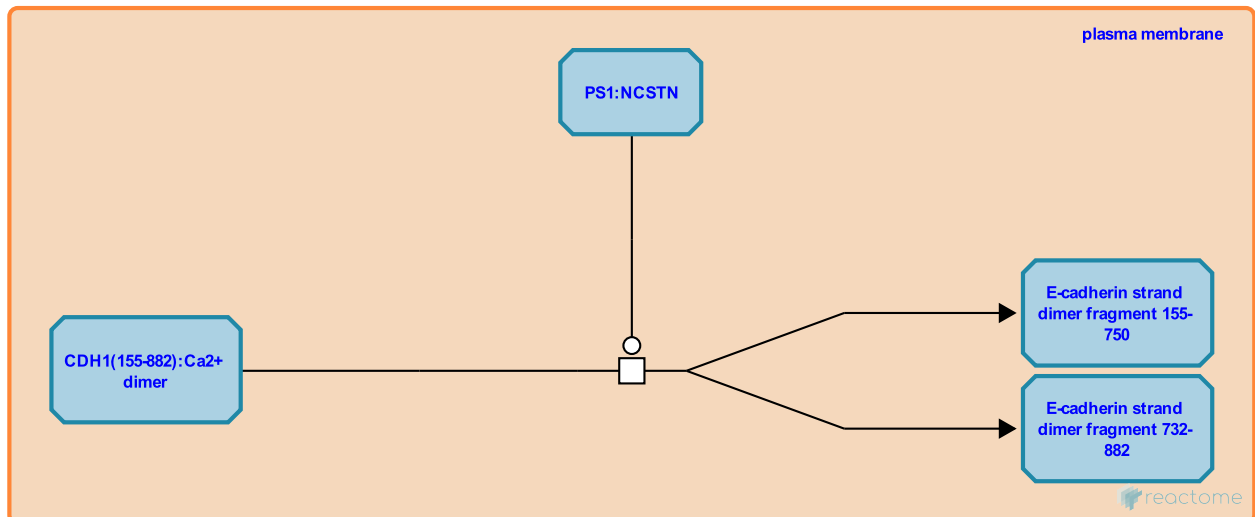

E-cadherin (CDH1) localizes to the lateral membrane of differentiated epithelia, providing the structural foundation for adherens junctions, multiprotein complexes that link cell-cell contacts to the actin cytoskeleton and various signaling molecules (Perez-Moreno et al. 2003, Baum & Georgiou 2011). The extracellular domain has five cadherin-type repeat ectodomain (EC) modules; the most membrane-distal EC mediates binding with CDH1 on adjacent cells (Boggon et al. 2002). Calcium ions bind between the EC domains of two CDH1 peptides to form a dimer with a rod-like conformation (Boggon et al. 2002) which is required for cell-cell interaction (Gumbiner 1996, Patel et al. 2006). The cytoplasmic tail of E-cadherin binds to the armadillo repeat protein beta-catenin, a target of the Wnt signaling pathway and a cofactor for TCF/LEF-mediated transcription (Gavard & Mège 2005). Beta-catenin in turn binds alpha-catenin, which interacts with the actin microfilament network, actin and the actin-binding proteins vinculin, formins, alpha-actinin, zonula occludin protein, and afadin (Bershadsky 2004). Cell-cell adhesions also contain desmosomes, which link cell contacts to intermediate filaments, and nectin-based, calcium-independent adhesions, which are linked to actin (Takai & Nakanishi 2003, Yin and Green 2004). The critical importance of E-cadherin to normal development and tissue function is demonstrated by embryonic lethal E-cadherin gene mouse knockouts (Larue et al. 1994). Loss of cadherin-based cell-cell adhesion is a hallmark of carcinogenesis, correlating with tumour progression, allowing cells to escape normal growth control signals, resulting in loss of differentiation and increased cell proliferation associated with invasive behaviour (Frixen et al. 1991, Capaldo & Macara 2007). Full-length 120-kDa CDH1 protein is cleaved in the ectodomain close to the plasma membrane by a number of metalloproteases, generating an extracellular 38-kDa C-terminal fragment (CTF) termed CTF1 which can be further processed by a gamma-secretase-like activity to a soluble 33-kDa CTF2 (Marambaud et al. 2002, Roy & Berx 2008). MMP3, MMP7 (Noë et al. 2001, canine MMPs), MMP9 (Symowicz et al. 2007), plasmin (Ryniers et al. 2002, canine plasmin), Kallikrien 7 (Johnson et al. 2007), ADAM10 (Maretzky et al. 2005) and ADAM15 (Najy et al. 2008) all cleave CDH1 extracellularly, close to the transmembrane region. Presenilin-1 (Marambaud et al. 2002), the catalytic subunit of gamma-secretase (Herreman et al. 2003, Li et al. 2003), cleaves CDH1 producing a soluble 33-kDa fragment termed CTF2. Caspase-3 (Steinhusen et al. 2001) and calpain-1 (Rios-Doria et al. 2003) cleave E-cadherin in its cytoplasmic part releasing an intracellular 37 kDa C-terminal fragment.

Editions

2012-08-08	Authored	Jupe, S.
2013-08-13	Edited	Jupe, S.
2013-08-13	Reviewed	Ricard-Blum, S.

E-cadherin degradation by caspase-3 and calpain-1 ↗

Location: [Degradation of the extracellular matrix](#)

Stable identifier: R-HSA-2534260

Type: transition

Compartments: plasma membrane

Inferred from: [E-cadherin strand dimer degradation by Casp3 \(Homo sapiens\)](#)

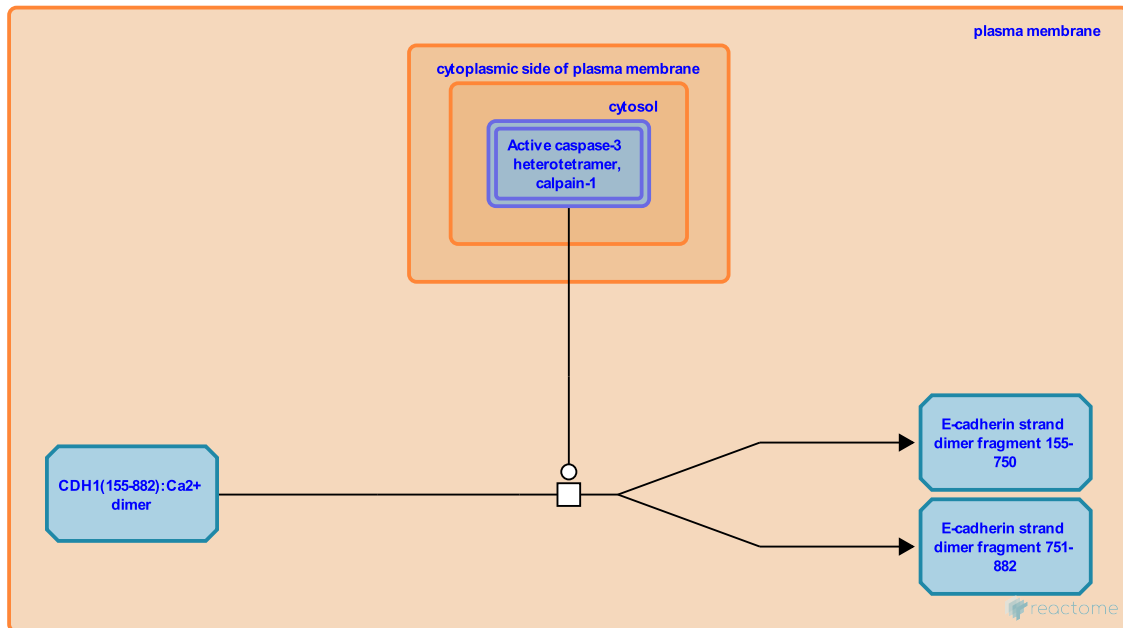

E-cadherin (CDH1) localizes to the lateral membrane of differentiated epithelia, providing the structural foundation for adherens junctions, multiprotein complexes that link cell-cell contacts to the actin cytoskeleton and various signaling molecules (Perez-Moreno et al. 2003, Baum & Georgiou 2011). The extracellular domain has five cadherin-type repeat ectodomain (EC) modules; the most membrane-distal EC mediates binding with CDH1 on adjacent cells (Boggon et al. 2002). Calcium ions bind between the EC domains of two CDH1 peptides to form a dimer with a rod-like conformation (Boggon et al. 2002) which is required for cell-cell interaction (Gumbiner 1996, Patel et al. 2006). The cytoplasmic tail of E-cadherin binds to the armadillo repeat protein beta-catenin, a target of the Wnt signaling pathway and a cofactor for TCF/LEF-mediated transcription (Gavard & Mège 2005). Beta-catenin in turn binds alpha-catenin, which interacts with the actin microfilament network, actin and the actin-binding proteins vinculin, formins, alpha-actinin, zonula occludin protein, and afadin (Bershadsky 2004). Cell-cell adhesions also contain desmosomes, which link cell contacts to intermediate filaments, and nectin-based, calcium-independent adhesions, which are linked to actin (Takai & Nakanishi 2003, Yin and Green 2004). The critical importance of E-cadherin to normal development and tissue function is demonstrated by embryonic lethal E-cadherin gene mouse knockouts (Larue et al. 1994). Loss of cadherin-based cell-cell adhesion is a hallmark of carcinogenesis, correlating with tumour progression, allowing cells to escape normal growth control signals, resulting in loss of differentiation and increased cell proliferation associated with invasive behaviour (Frixen et al. 1991, Capaldo & Macara 2007). Full-length 120-kDa CDH1 protein is cleaved in the ectodomain close to the plasma membrane by a number of metalloproteases, generating an extracellular 38-kDa C-terminal fragment (CTF) termed CTF1 which can be further processed by a gamma-secretase-like activity to a soluble 33-kDa CTF2 (Marambaud et al. 2002, Roy & Berx 2008). MMP3, MMP7 (Noë et al. 2001, canine MMPs), MMP9 (Symowicz et al. 2007), plasmin (Ryniers et al. 2002, canine plasmin), Kallikrien 7 (Johnson et al. 2007), ADAM10 (Maretzky et al. 2005) and ADAM15 (Najy et al. 2008) all cleave CDH1 extracellularly, close to the transmembrane region. Presenilin-1 (Marambaud et al. 2002), the catalytic subunit of gamma-secretase (Herreman et al. 2003, Li et al. 2003), cleaves CDH1 producing a soluble 33-kDa fragment termed CTF2. Caspase-3 (Steinhusen et al. 2001) and calpain-1 (Rios-Doria et al. 2003) cleave E-cadherin in its cytoplasmic part releasing an intracellular 37 kDa C-terminal fragment termed CTF3.

Editions

2012-08-08	Authoried	Jupe, S.
2013-08-13	Edited	Jupe, S.
2013-08-13	Reviewed	Ricard-Blum, S.

MMP1,3,13 (2, 7-12, 19) binding by Alpha-2 macroglobulin ↗

Location: [Degradation of the extracellular matrix](#)

Stable identifier: R-HSA-1454781

Type: binding

Compartments: extracellular region

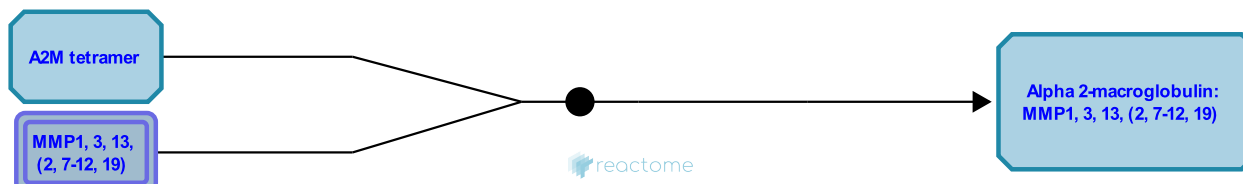

Alpha 2-macroglobulin (A2M) is a plasma glycoprotein consisting of 4 near-identical subunits (Andersen et al. 1995). A2M inhibits almost all endopeptidases regardless of their specificities (Barrett 1981). A2M binding to an endopeptidase is triggered by cleavage of a peptide bond in the 'bait region' of A2M, triggering a conformational change in A2M that in turn entraps the peptidase without blocking the active site (Barrett & Starkey 1973). This blocks enzyme activity against large protein substrates while not preventing activity on low molecular weight substrates.

Once bound, A2M-proteinase complexes are endocytosed by low density lipoprotein receptor-related protein-1 (LRP1) (Strickland et al. 1990).

Active metalloproteinases (MMPs) that can be entrapped by A2M include MMP3 (Enghild et al. 1989) MMP1 (Grinnell et al. 1998) and MMP 13 (Beekman et al. 1999).

The significance of this mechanism as a regulator of MMP activity is unclear (Baker et al. 2002, Nagase et al. 2006).

Literature references

Williams, S., Ashcom, JD., Burgess, WH., Migliorini, M., Strickland, DK., Argraves, WS. (1990). Sequence identity between the alpha 2-macroglobulin receptor and low density lipoprotein receptor-related protein suggests that this molecule is a multifunctional receptor. *J Biol Chem*, 265, 17401-4. ↗

Editions

2012-08-08	Authored	Jupe, S.
2013-08-13	Edited	Jupe, S.
2013-08-13	Reviewed	Ricard-Blum, S.

MMP2, MMP7, MMP9 bind CD44 ↗

Location: [Degradation of the extracellular matrix](#)

Stable identifier: R-HSA-1454791

Type: binding

Compartments: plasma membrane, extracellular region

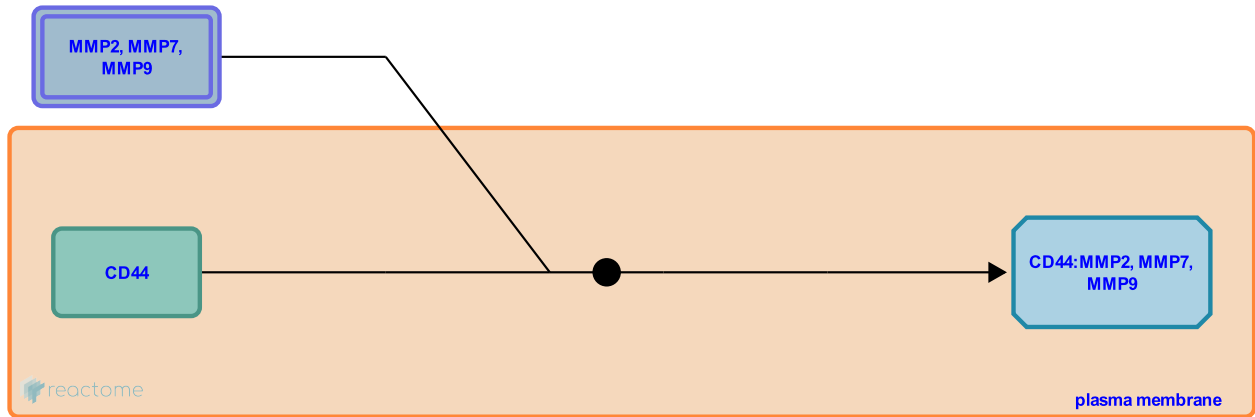

Certain normally extracellular MMPs can transiently localize at the cell periphery in association with adhesion receptors or proteoglycans. ProMMP9, MMP9, MMP2 and MMP7 (Ahmed et al. 2002, Samanna et al. 2006, Yu et al. 2002) localize at the cell membrane with the single-pass transmembrane glycoprotein CD44, known to be involved in hyaluronan-cell interactions, lymphocyte homing and cell adhesion (Toole 1990). Membrane-associated MMP7 can bring about the shedding of several membrane proteins such as epidermal growth factor (EGF), soluble Fas ligand (FasL), E-cadherin and TNF-alpha from their membrane-bound precursors, thereby promoting cancer progression (Li et al. 2006). CD44-anchored MMP9 cleaves and activates transforming growth factor beta (TGF- β), degrades extracellular matrix components such as laminin, and regulates function of several membrane bound proteins (Yu Q & Stamenkovic I 2000; reviewed by Augoff K et al. 2022). MMP9 is able to cleave CD44 as shown in neurons (Bijata M et al. 2017). The CD44:MMP9 interaction is thought to promote tumor invasion and metastatic ability (Yu Q & Stamenkovic I 2000; Peng ST et al. 2007).

Literature references

- Chellaiah, MA., Wei, H., Ego-Osuala, D., Samanna, V. (2006). Alpha-V-dependent outside-in signaling is required for the regulation of CD44 surface expression, MMP-2 secretion, and cell migration by osteopontin in human melanoma cells. *Exp. Cell Res.*, 312, 2214-30. ↗
- Quinn, MA., Mok, S., Agrez, MV., Baker, MS., Ahmed, N., Rice, GE. et al. (2002). Overexpression of alpha(v)beta6 integrin in serous epithelial ovarian cancer regulates extracellular matrix degradation via the plasminogen activation cascade. *Carcinogenesis*, 23, 237-44. ↗
- Toole, BP. (1990). Hyaluronan and its binding proteins, the hyaladherins. *Curr. Opin. Cell Biol.*, 2, 839-44. ↗

Editions

2012-08-08	Authored	Jupe, S.
2013-08-13	Edited	Jupe, S.
2013-08-13	Reviewed	Ricard-Blum, S.

Basigin binds Matrix metalloproteinase-1 [↗](#)

Location: [Degradation of the extracellular matrix](#)

Stable identifier: R-HSA-375135

Type: binding

Compartments: plasma membrane, extracellular region

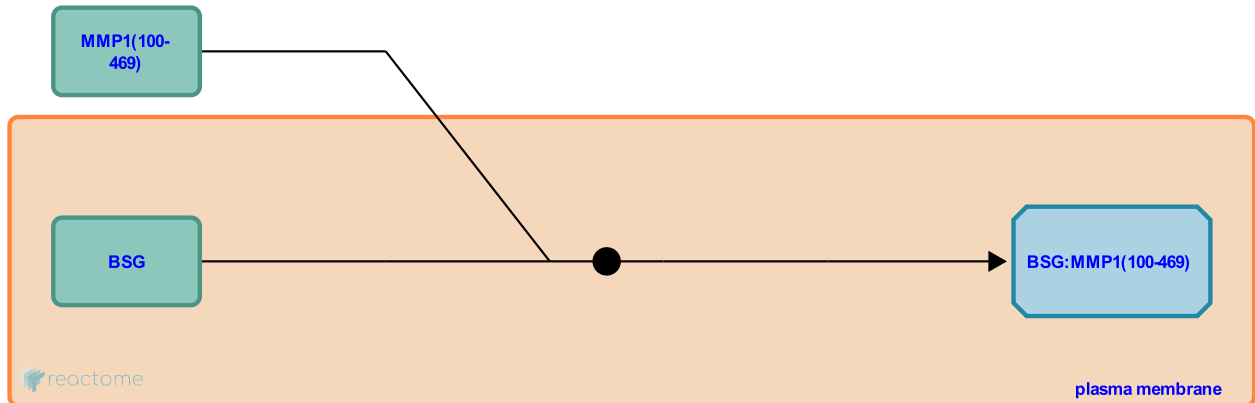

Basigin (BSG, CD147, EMPRIN) is a glycoprotein expressed on the surface of most tumor cells. It stimulates stromal cells to produce elevated levels of several matrix metalloproteinases (MMP), including interstitial collagenase (MMP1). MMPs have been implicated in several aspects of tumor progression, including invasion through basement membranes and interstitial matrices, angiogenesis, and tumor cell growth. Basigin not only stimulates the production of MMP1 but also forms a complex with MMP1 at the tumor cell surface. This interaction may be important in modifying the tumor cell pericellular matrix to promote invasion.

Literature references

Zucker, S., Toole, BP., Li, R., Guo, H. (2000). EMMPRIN (CD147), an inducer of matrix metalloproteinase synthesis, also binds interstitial collagenase to the tumor cell surface. *Cancer Res*, 60, 888-91. [↗](#)

Editions

2008-02-26	Authored	de Bono, B., Garapati, P V.
2008-02-26	Reviewed	Trowsdale, J.
2009-03-16	Edited	Garapati, P V.

OPN (osteopontin) degradation by MMP3, MMP7 ↗

Location: [Degradation of the extracellular matrix](#)

Stable identifier: R-HSA-4086205

Type: transition

Compartments: extracellular region

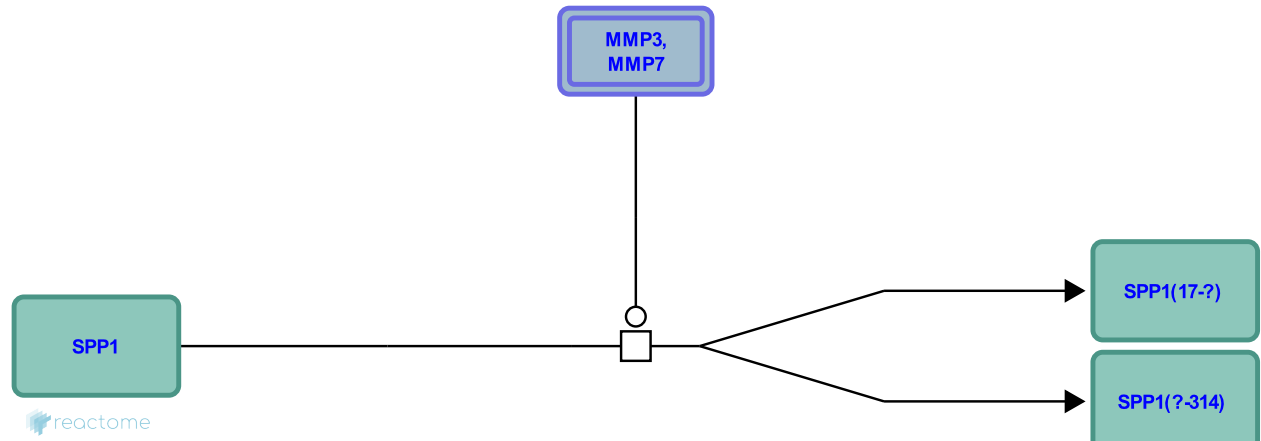

OPN is a substrate for MMP3 and MMP7. Three cleavage sites were identified, Gly166-Leu167, Ala201-Tyr202 (MMP-3 only), and Asp210-Leu211. The resulting OPN fragments facilitate adhesion and migration in vitro through activation of beta1-containing integrins (Agnihotri et al. 2001). OPN has also been shown to be a substrate for liver transglutaminase and plasma transglutaminase factor IIIa, resulting in protein crosslinking (Prince et al. 1991), enhanced cell adhesion, spreading, focal contact formation and migration

Literature references

Haro, H., Agnihotri, R., Havrda, MC., Liaw, L., Crawford, HC., Matrisian, LM. (2001). Osteopontin, a novel substrate for matrix metalloproteinase-3 (stromelysin-1) and matrix metalloproteinase-7 (matrilysin). *J. Biol. Chem.*, 276, 28261-7. ↗

Editions

2012-08-08	Authored	Jupe, S.
2013-08-13	Edited	Jupe, S.
2013-08-13	Reviewed	Ricard-Blum, S.

CAPN:4xCa²⁺:CAPNS cleave cytoskeletal proteins ↗

Location: Degradation of the extracellular matrix

Stable identifier: R-HSA-8848658

Type: transition

Compartments: cytosol

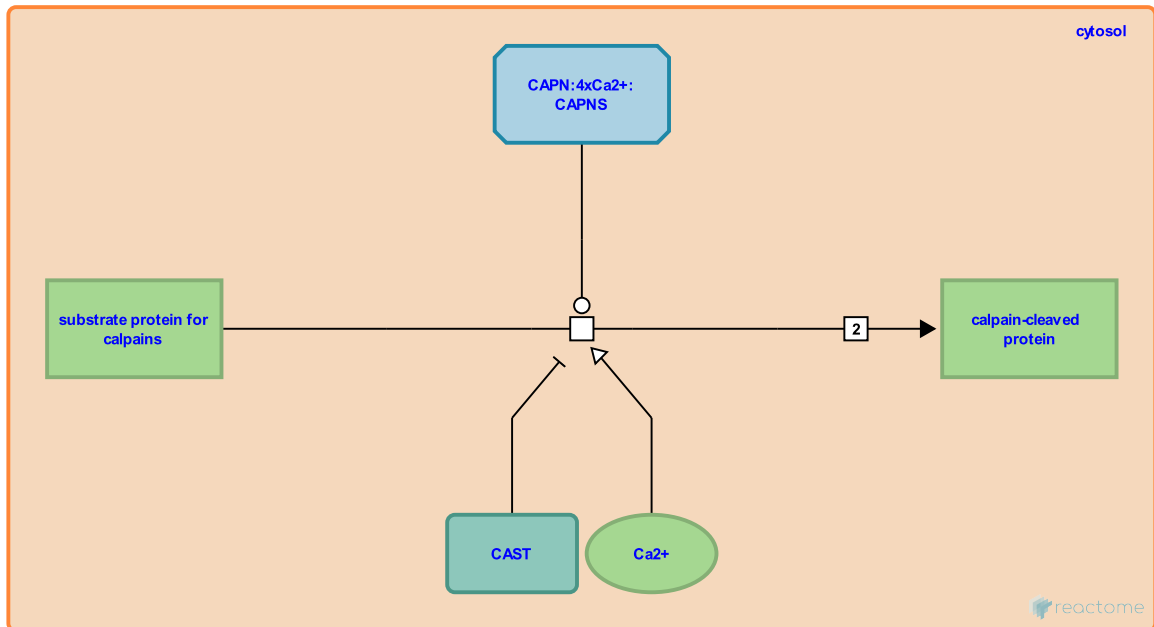

Calpains (EC 3.4.22.17; CAPN, Clan CA, family C02) constitute a distinct group of intracellular cysteine proteases found in almost all eukaryotes and a few bacteria. Calpains can be described as cytosolic proteases exhibiting Ca²⁺-dependent limited proteolytic activity which function to transform or modulate their substrate proteins' structures and activities; they are therefore called modulator proteases. As calpains selectively cleave proteins in response to calcium signals, they have the potential to influence cellular functions such as signal transduction, cytoskeletal remodelling, cell motility, membrane repair, cell cycle progression, gene expression and apoptosis (Sorimachi et al. 2010). Calpain deficiencies are linked to a variety of defects in many different organisms, including lethality, muscular dystrophies, gastropathy and diabetes (Sorimachi et al. 2011).

The human genome has 15 genes (named using formal nomenclature as CAPN1, CAPN2, etc.) that encode a calpain-like protease domain. The two best-characterised members of the calpain family, CAPN1 and 2, are ubiquitously expressed and locate to the cytosol of the cell (Goll et al. 2003). All other calpains annotated here are assumed to be functionally similar to these two based on their structural similarities. They are heterodimers, consisting of a common small regulatory subunit (CAPNS1 or CAPNS2; ca. 30kDa) and a large, isoform-specific catalytic subunit. Three-dimensional structural analyses reveal the calpain protease domain comprises two core domains that fuse to form a functional protease only when bound to ca. four Ca²⁺ ions via well-conserved amino acids. So, despite the fact that they have divergent domain structures, calpains share this mechanistic functional character (Croall & Ersfeld 2007, Sorimachi et al. 2011, Ono & Sorimachi 2012).

Calpain activity is tightly regulated by the endogenous inhibitor calpastatin (CAST), which is capable of reversibly binding and inhibiting four molecules of calpain in the presence of calcium. This suggests calpains are transiently activated by high Ca²⁺ concentrations such as a Ca²⁺ influx, and then return to an inactive state ready for reactivation (Campbell & Davies 2012).

Literature references

Hata, S., Ono, Y., Sorimachi, H. (2011). Calpain chronicle--an enzyme family under multidisciplinary characterization. *Proc. Jpn. Acad., Ser. B, Phys. Biol. Sci.*, 87, 287-327. ↗

Ono, Y., Sorimachi, H. (2012). Calpains: an elaborate proteolytic system. *Biochim. Biophys. Acta*, 1824, 224-36. ↗

Cong, J., Goll, DE., Thompson, VF., Li, H., Wei, W. (2003). The calpain system. *Physiol. Rev.*, 83, 731-801. ↗

Hata, S., Ono, Y., Sorimachi, H. (2010). Expanding members and roles of the calpain superfamily and their genetically modified animals. *Exp. Anim.*, 59, 549-66. [↗](#)

Campbell, RL., Davies, PL. (2012). Structure-function relationships in calpains. *Biochem. J.*, 447, 335-51. [↗](#)

Editions

2015-12-10	Authored, Edited	Jassal, B.
2015-12-14	Reviewed	D'Eustachio, P.

MMP2 cleaves OPTC ↗

Location: [Degradation of the extracellular matrix](#)

Stable identifier: R-HSA-8940554

Type: transition

Compartments: extracellular region

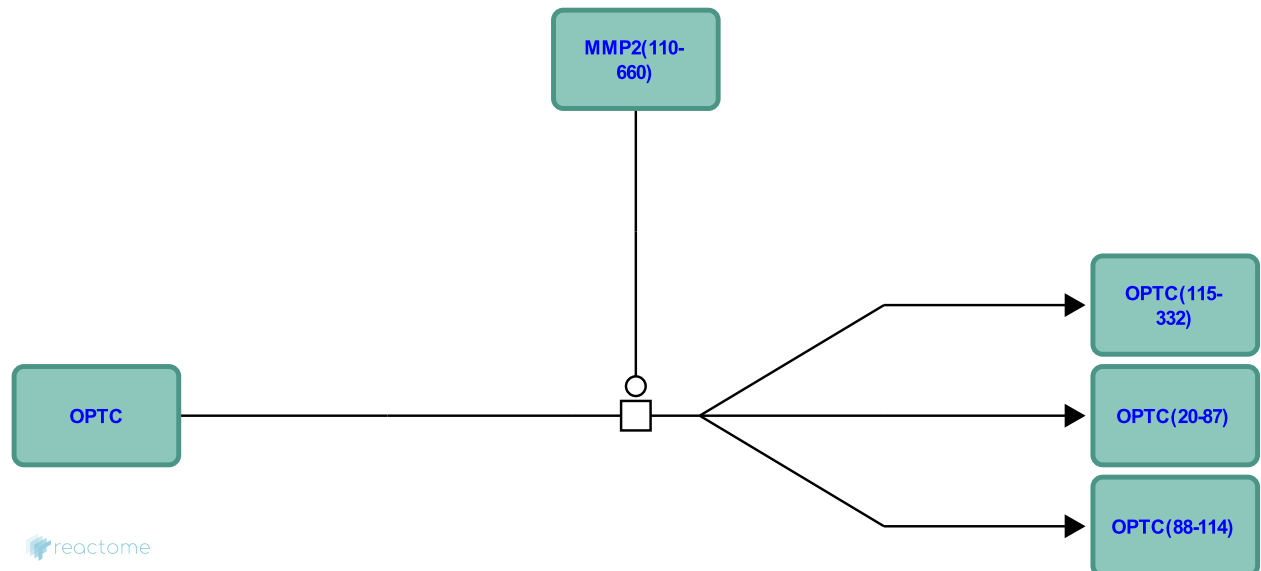

Opticin (OPTC) is a member of the small leucine-rich repeat proteoglycan family (Reardon et al. 2000). It is found in the vitreous cavity of the eye where it co-localizes with the fine network of collagen fibrils that maintains the gel state of the vitreous and the inner-limiting lamina, and in other tissues, including the brain, heart, and cartilage (Le Goff et al. 2012). It forms a homodimer in solution through its leucine-rich repeats (Le Goff et al. 2003). OPTC has anti-angiogenic activity which is mediated by binding to vitreous collagen fibrils, which are composed of collagens II, IX, and V/XI (Bishop 2000). This binding competitively inhibits endothelial cell interactions with collagen I via Alpha-1Beta-1 and Alpha-2Beta-1 integrins, preventing proangiogenic signaling via these integrins (Le Goff et al. 2012). OPTC is expressed and translocated to the nucleus of chronic lymphocytic leukemia cells (Mikaelsson et al. 2013).

OPTC can be degraded by Matrix metalloprotease (MMP) -1, -2, -3, -7, -8, -9, -13 and by ADAMTS4 and ADAMTS5, with MMP2 and MMP7 having highest activity towards the recombinant protein (Montfort et al. 2008, Ma et al. 2012, Tio et al. 2014). MMP2 cleaves OPTC at T87/S88 and G114/L115 (Tio et al. 2014).

Literature references

Farran, A., Martel-Pelletier, J., Monfort, J., Benito, P., Roughley, P., Tío, L. et al. (2014). Characterization of opticin digestion by proteases involved in osteoarthritis development. *Joint Bone Spine*, 81, 137-41. ↗

Editions

2016-09-27	Authored	Jupe, S.
2016-09-30	Edited	Jupe, S.
2016-10-12	Reviewed	Ricard-Blum, S.

MMP7 cleaves OPTC ↗

Location: [Degradation of the extracellular matrix](#)

Stable identifier: R-HSA-8940561

Type: transition

Compartments: extracellular region

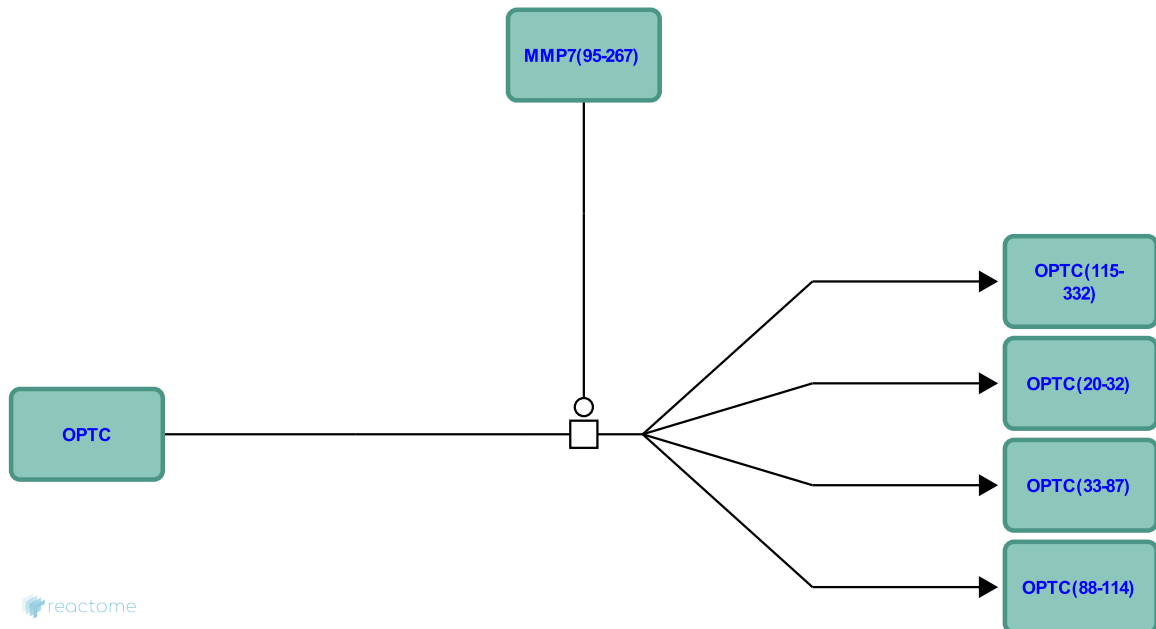

Opticin (OPTC) is a member of the small leucine-rich repeat proteoglycan family (Reardon et al. 2000). It is found in the vitreous cavity of the eye where it co-localizes with the fine network of collagen fibrils that maintains the gel state of the vitreous and the inner-limiting lamina, and in other tissues, including the brain, heart, and cartilage (Le Goff et al. 2012). It forms a homodimer in solution through its leucine-rich repeats (Le Goff et al. 2003). OPTC has anti-angiogenic activity which is mediated by binding to vitreous collagen fibrils, which are composed of collagens II, IX, and V/XI (Bishop 2000). This binding competitively inhibits endothelial cell interactions with collagen I via Alpha-1Beta-1 and Alpha-2Beta-1 integrins, preventing proangiogenic signaling via these integrins (Le Goff et al. 2012). OPTC is expressed and translocated to the nucleus of chronic lymphocytic leukemia cells (Mikaelsson et al. 2013).

OPTC can be degraded by Matrix metalloprotease (MMP) -1, -2, -3, -7, -8, -9, -13 and by ADAMTS-4 and ADAMTS-5, with MMP2 and MMP7 having highest activity towards the recombinant protein (Montfort et al. 2008, Ma et al. 2012, Tio et al. 2014). MMP7 cleaves recombinant human OPTN at four positions, A20/S21LP (removing the signal peptide), E32/Q33, T87/S88, and G114/L115.

Literature references

Farran, A., Martel-Pelletier, J., Monfort, J., Benito, P., Roughley, P., Tío, L. et al. (2014). Characterization of opticin digestion by proteases involved in osteoarthritis development. *Joint Bone Spine*, 81, 137-41. ↗

Editions

2016-09-27	Authored	Jupe, S.
2016-09-30	Edited	Jupe, S.
2016-10-12	Reviewed	Ricard-Blum, S.

MMP13 cleaves OPTC ↗

Location: [Degradation of the extracellular matrix](#)

Stable identifier: R-HSA-8942302

Type: transition

Compartments: extracellular region

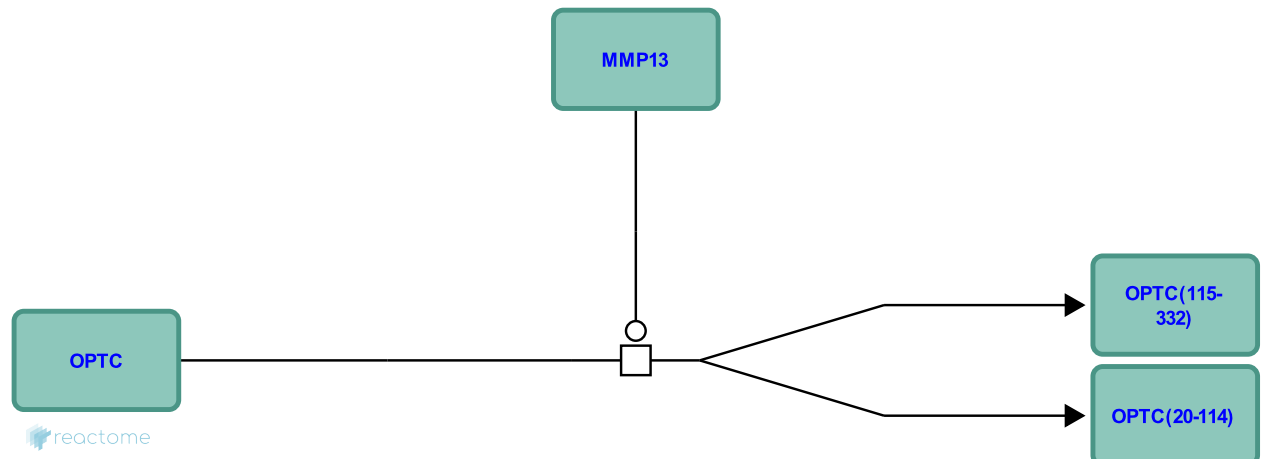

Opticin (OPTC) is a member of the small leucine-rich repeat proteoglycan family (Reardon et al. 2000). It is found in the vitreous cavity of the eye where it co-localizes with the fine network of collagen fibrils that maintains the gel state of the vitreous and the inner-limiting lamina, and in other tissues, including the brain, heart, and cartilage (Le Goff et al. 2012). It forms a homodimer in solution through its leucine-rich repeats (Le Goff et al. 2003). Opticin has anti-angiogenic activity which is mediated by binding to vitreous collagen fibrils, which are composed of collagens II, IX, and V/XI (Bishop 2000). This binding competitively inhibits endothelial cell interactions with collagen I via Alpha-1Beta-1 and Alpha-2Beta-1 integrins, preventing proangiogenic signaling via these integrins (Le Goff et al. 2012). OPTC is expressed and translocated to the nucleus of chronic lymphocytic leukemia cells (Mikaelsson et al. 2013).

OPTC can be degraded by Matrix metalloprotease (MMP) -1, -2, -3, -7, -8, -9, -13 and by ADAMTS-4 and ADAMTS-5, with MMP2 and MMP7 having highest activity towards the recombinant protein (Montfort et al. 2008, Ma et al. 2012, Tio et al. 2014). MMP13 cleaves recombinant bovine OPTC at G104/L105 (major product), and P109/A110 (minor product) (Montfort et al. 2008). The major cleavage site corresponds to G114/L115 in human opticin.

Literature references

Farran, A., Martel-Pelletier, J., Monfort, J., Benito, P., Roughley, P., Tío, L. et al. (2014). Characterization of opticin digestion by proteases involved in osteoarthritis development. *Joint Bone Spine*, 81, 137-41. ↗

Editions

2016-09-27	Authored	Jupe, S.
2016-09-30	Edited	Jupe, S.
2016-10-12	Reviewed	Ricard-Blum, S.

MMP2, MMP9 cleave SCUBE3 ↗

Location: [Degradation of the extracellular matrix](#)

Stable identifier: R-HSA-8943959

Type: transition

Compartments: plasma membrane

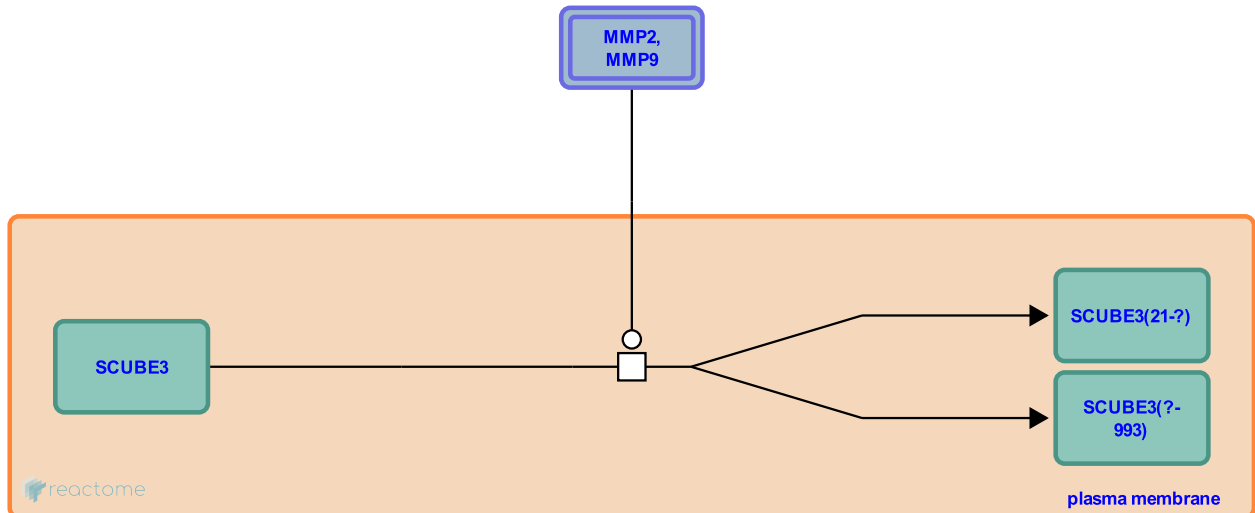

Signal peptide-CUB-EGF-like domain-containing protein 3 (SCUBE3) is a secreted glycoprotein that is highly expressed in osteoblasts. It can form homooligomers and heterooligomers with SCUBE1, which stably associate with the peripheral cell surface. In normal lung it is mainly expressed in bronchial epithelial cells. Its expression is upregulated in some lung cancer tumors and correlates with invasive ability in a lung cancer cell line model (Wu et al. 2004, 2011). SCUBE3 knockdown is associated with lower tumor vascular permeability, inhibiting the metastatic potential of Non-small-cell lung carcinoma (Chou et al. 2013).

SCUBE3 can be cleaved by the gelatinases Matrix metalloprotease-2 (MMP2) and MMP9, releasing two major fragments. The C-terminal fragment contains a complement proteins C1r/C1s, Uegf and Bmp1 (CUB) domain. The secreted SCUBE3 protein and the C-terminal CUB domain fragment can bind the Transforming growth factor beta type II receptor (TGFBR2) and activate signaling (Wu et al. 2011). SCUBE3 may act as an FGF co-receptor, augmenting FGF8 signaling (Tu et al. 2014). Overexpression of Scube3 has been linked to significant murine cardiac hypertrophy (Yang et al. 2007). The C-terminal portion of SCUBE3 can physically interact with Transforming growth factor beta-1 (TGFB1) and promote TGFB1-mediated transcriptional activation in vitro (Yang et al. 2007). Consistent with this, the phosphorylated and total protein levels of Smad2, a well-known TGFB1 downstream signaling molecule, are elevated in Scube3 transgenic mouse heart under pressure overload. SCUBE3 may be a component of the regulatory mechanisms for active TGFB1 bioavailability, either systemically or locally in cardiac tissues, under baseline conditions and during pathological stresses. A Scube3 mutant mouse line (carrying a missense mutation in exon 8) has phenotypic alterations that suggest a role of Scube3 in bone metabolism and morphology, hearing, and renal function. The observed morphological abnormalities of the skeleton, impaired bone metabolism and hearing impairments are comparable with the rare metabolic bone disorder Paget disease, which is associated with the chromosomal region that includes SCUBE3 (Fuchs et al. 2016).

Literature references

Lin, JC., Pan, SH., Peck, K., Hong, TM., Yang, PC., Cheng, YF. et al. (2011). SCUBE3 is an endogenous TGF- β receptor ligand and regulates the epithelial-mesenchymal transition in lung cancer. *Oncogene*, 30, 3682-93. ↗

Editions

2016-11-01	Authored	Jupe, S.
2017-01-18	Edited	Jupe, S.
2017-01-20	Reviewed	Xavier, X.

SCUBE1, SCUBE3 oligomerize ↗

Location: [Degradation of the extracellular matrix](#)

Stable identifier: R-HSA-8943987

Type: transition

Compartments: plasma membrane

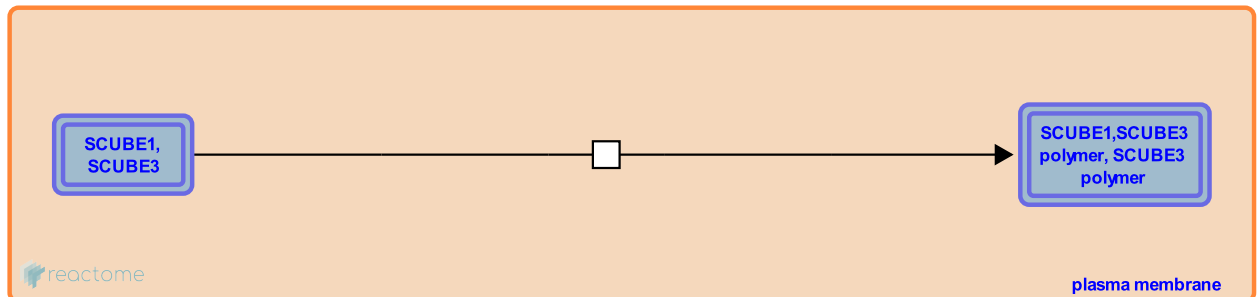

Signal peptide-CUB-EGF-like domain-containing protein 3 (SCUBE3) is a secreted glycoprotein that is highly expressed in osteoblasts. It can form homooligomers and heterooligomers with SCUBE1, which stably associate with the peripheral cell surface (Wu et al. 2004). Overexpression of Scube3 has been linked to significant murine cardiac hypertrophy (Yang et al. 2007). The C-terminal portion of SCUBE3 can physically interact with Transforming growth factor beta-1 (TGFB1) and promote TGFB1-mediated transcriptional activation in vitro (Yang et al. 2007). Consistent with this, the phosphorylated and total protein levels of Smad2, a well-known TGFB1 downstream signaling molecule, are elevated in Scube3 transgenic mouse heart under pressure overload. SCUBE3 may be a component of the regulatory mechanisms for active TGFB1 bioavailability, either systemically or locally in cardiac tissues, under baseline conditions and during pathological stresses. A Scube3 mutant mouse line (carrying a missense mutation in exon 8) has phenotypic alterations that suggest a role of Scube3 in bone metabolism and morphology, hearing, and renal function. The observed morphological abnormalities of the skeleton, impaired bone metabolism and hearing impairments are comparable with the rare metabolic bone disorder Paget disease, which is associated with the chromosomal region that includes SCUBE3 (Fuchs et al. 2016).

Literature references

Su, YH., Wasserman, SM., Wu, BT., Tsai, MT., Topper, JN., Yang, RB. (2004). A novel secreted, cell-surface glycoprotein containing multiple epidermal growth factor-like repeats and one CUB domain is highly expressed in primary osteoblasts and bones. *J. Biol. Chem.*, 279, 37485-90. ↗

Editions

2016-11-01	Authored	Jupe, S.
2017-01-18	Edited	Jupe, S.
2017-01-20	Reviewed	Xavier, X.

Table of Contents

Introduction	1
❏ Degradation of the extracellular matrix	2
❏ Activation of Matrix Metalloproteinases	3
❏ Collagen degradation	4
🔗 Elastin degradation by elastin-degrading extracellular proteinases	6
🔗 Elastin degradation by MMP14	7
🔗 Fibrillin 1, 2,(3) degradation by MMP2, 9, 12 and 13	8
🔗 Fibrillin-1 degradation by MMP3, CTSK, CTSL2	9
🔗 Fibrillin-1 degradation by MMP14	10
🔗 Fibrillin-1 degradation by ELANE	11
🔗 Fibronectin degradation by MMP1, 3, 7, 12, 13, 19, CTSS	12
🔗 Fibronectin degradation by MMP10	13
🔗 Fibronectin degradation by MMP14	14
🔗 Fibronectin degradation by CTSG	15
🔗 Fibronectin degradation by ADAM8	16
🔗 Laminin-322 degradation by laminin-322 degrading extracellular proteinases	17
🔗 Laminin-322 degradation by MMP14	18
🔗 Laminin-511 degradation by MMP14	19
🔗 NID1 degradation by MMP1, 9, 12, ELANE	20
🔗 NID1 degradation by MMP3, 7	21
🔗 NID1 degradation by MMP14, MMP15	22
🔗 NID1 degradation by MMP19	23
🔗 Aggrecan degradation by ADAMTSs	24
🔗 Aggrecan degradation by MMP1,2,3,7,9,12,13	25
🔗 HTRA1 hydrolyzes ACAN (Aggrecan)	26
🔗 Brevican degradation by ADAMTS4, ADAMTS5	27
🔗 Brevican degradation by MMP1, 2, 3, 7,8,10,13,19	28
🔗 HSPG2 (perlecan) degradation by MMP3, plasmin, (MMP12)	29
🔗 HSPG2 (perlecan) degradation by MMP13, CTSS	30
🔗 HSPG2 (perlecan) degradation by MMP14, MMP15	31
🔗 HSPG2 (perlecan) is cleaved by BMP1, TLL1, TLL2, Cathepsin L1	32
🔗 DCN (decorin) degradation by MMP2, MMP3, MMP7	33
🔗 DCN (decorin) degradation by MMP14	34
🔗 E-cadherin degradation by MMP3, MMP7 and plasmin.	35

↳ E-cadherin degradation by MMP9, KLK7	36
↳ E-cadherin degradation by ADAM10, ADAM15	38
↳ E-cadherin degradation by PS1:NCSTN (Gamma-secretase)	40
↳ E-cadherin degradation by caspase-3 and calpain-1	41
↳ MMP1,3,13 (2, 7-12, 19) binding by Alpha-2 macroglobulin	42
↳ MMP2, MMP7, MMP9 bind CD44	43
↳ Basigin binds Matrix metalloproteinase-1	44
↳ OPN (osteopontin) degradation by MMP3, MMP7	45
↳ CAPN:4xCa ²⁺ :CAPNS cleave cytoskeletal proteins	46
↳ MMP2 cleaves OPTC	48
↳ MMP7 cleaves OPTC	49
↳ MMP13 cleaves OPTC	50
↳ MMP2, MMP9 cleave SCUBE3	51
↳ SCUBE1, SCUBE3 oligomerize	52
Table of Contents	53